

BADLANDS LE-CB CAN/Bus Load Equalizer Module

Thank you for purchasing a Badlands CAN/Bus Load Equalizer Module! We're sure that you will be completely satisfied with the performance and ease of installation of your new module. Before you get started, PLEASE read these instructions and helpful tips so that you understand how to install your module correctly. An improper installation will void the warranty.

FEATURES: All CB or CAN/Bus Badlands Load Equalizer Modules are designed to provide you the ability to use small incandescent bulbs, Halogen bulbs or LED style (or any non-compliant CAN/Bus turn signal) turn signals without a rapid flash or trouble code. **(INSTALL OUR MODULE BEFORE YOU INSTALL YOUR NEW LIGHTS!)** A "rapid-flash" is caused by the factory turn signal module not seeing the specific amperage draw that the factory installed 1156/1157 bulbs provided. Whether you have a Plug-n-Play module or the hard-wired version, Load Equalizer Modules all work the same. Now you understand the features of our Load Equalizer Module, let's talk about how it works.

HARD-WIRED INSTALLATION: (FRONT TURN SIGNALS ONLY) On the hard-wired modules, you can use any installation method you choose but **DISCONNECT** the battery **FIRST!** We package this version with (1) ring terminal and quick splices but we recommend using connectors and terminals whenever possible. Install the LE-CB near the BCM module for use on front turn signals. Use the supplied quick splices to "splice" into the LEFT TURN signal wire (BLUE/) and the RIGHT TURN signal wire (BROWN). On pre-'96 models, the wire colors will be different so be sure to consult your bikes service manual for exact wiring diagrams and color descriptions to achieve proper installation. The diagram below shows you to "splice into" these (2) wires while still keeping the wires connected as they were from the factory. Be sure to connect the (fused) ORANGE and BLACK wires to the directly to the battery as shown to prevent "bleed" or radio interference.

PLUG-N-PLAY INSTALLATION: Most of our modules offer Plug-n-Play technology, making installation quick and easy. Simply remove your seat or left side cover on FL Models, unplug the **rear fender harness** connectors, plug our module in between and you're done.

LE-CB: Hard-wired module, universal fitment for **(FRONT SIGNALS ONLY)** 2011-Up Softail, 2012-Up Dyna and ALL 2014-Up Models EXCEPT VROD, comes complete with (2) 1/4" ring terminal for the BLACK wire to be connected directly to battery post or frame ground and one for the ORANGE wire to be connected to the positive or (+) of the battery, (2) quick splices to attach to the front turn signal wires located on the BCM, BLUE/PINK (left) and BLUE/ORANGE (right) to the matching color input wires on our LE-CB module.

LE-CB-A: Plug-n-Play module, fits (2011-Up Softail, 2012-Up Dyna, FXDF, FXDB/P, FXDWG, FLD, FXDC/L, FLSTC, FLSTF/B, FLSTN, FXST) This module comes with an 8-position male and female Multilock connector that connects in between your rear fender connection under the seat.

LE-CB-B: Plug-n-Play module, fits (2011-Up FXS/B and 2012-Up FLS/S ONLY) This module comes with (2) 4-position male and female Mini-Deutsch connectors that connect in between your rear fender connection under the seat.

LE-CB-C: Plug-n-Play module, fits (All 2014-Up XL Models) This module comes with (2) 4-position male and female Mini-Multilock connectors that connect in between your rear fender connection under the seat.

LE-CB-D: Plug-n-Play module, fits (All 2014-Up Touring Models) This module comes with a 6-position male and female Molex connectors that connect in between your rear fender connection under the seat.

****NOTE: Our LE-CB modules DO NOT operate both FRONT and REAR turn signals as our pre-CAN/Bus modules have done in the past. It is NECESSARY to use our LE-CB Hard-wired module for front, non-compliant turn signals on ALL CAN/Bus bikes and a SEPARATE, LE-CB-A, B, C or D version for the rear.****

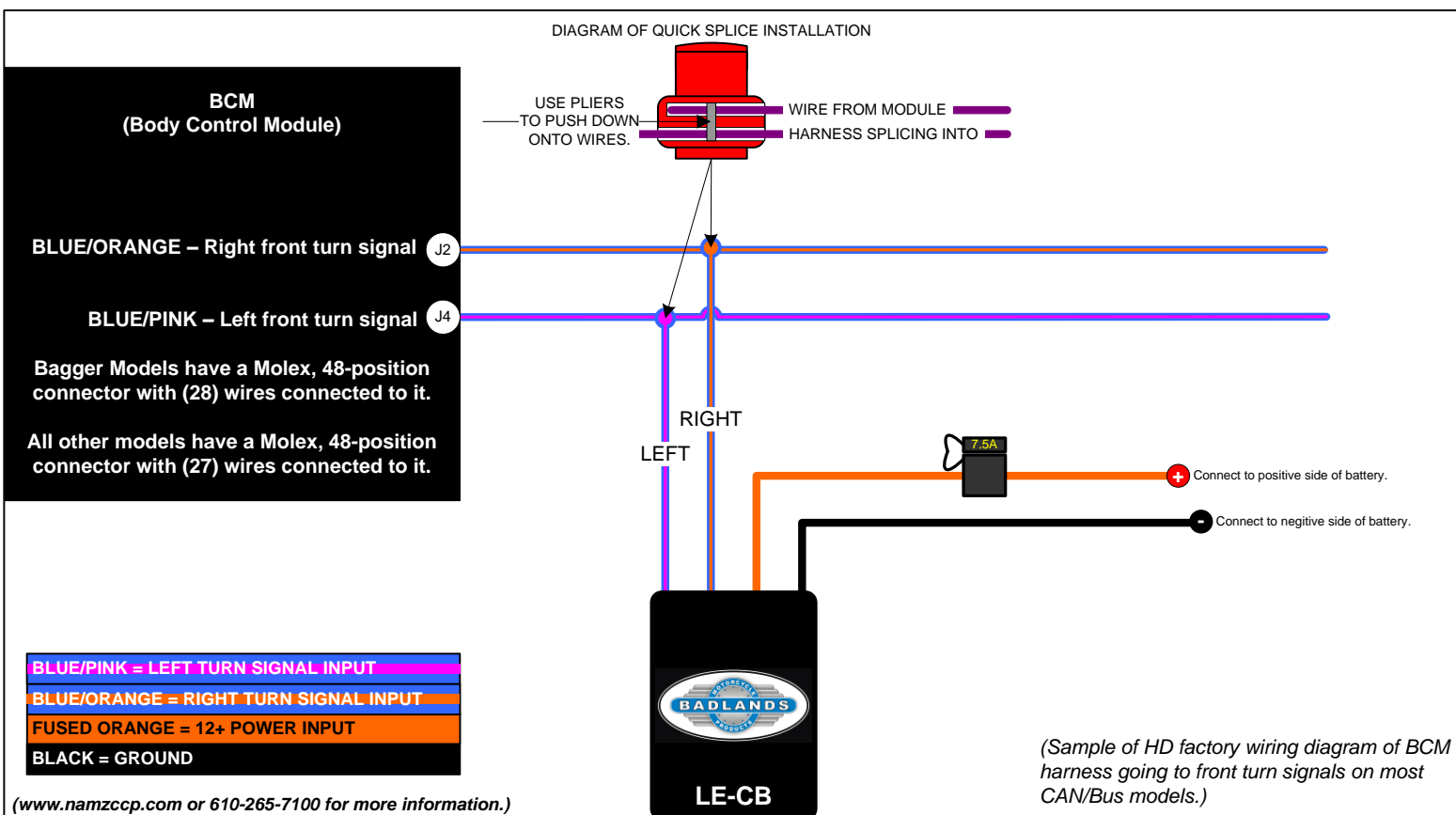

BADLANDS ILL-CB CAN/Bus Illuminator RUN-BRAKE-TURN Module with LOAD EQUALIZER

Thank you for purchasing a Badlands Illuminator Module! We're sure that you will be completely satisfied with the performance and ease of installation of your new module. Before you get started, PLEASE read these instructions and helpful tips so that you understand how to install your module correctly. An improper installation will void the warranty.

FEATURES: All CB or CAN/Bus Badlands Illuminator Modules are designed to provide you running light, brake light and turn signal functions to each rear turn signal all on (1) wire per side. These modules also have a built-in Load Equalizer which is perfect when switching out factory turn signals to non-compliant LED versions. This feature will prevent a "rapid-flashing" indicator lights and trouble codes which is caused by the factory turn signal module not seeing the specific amperage draw that the factory 1156/1157 bulbs provided. Now you understand the features of our Illuminator Module, let's talk about how it works.

WIRING OF NON PLUG-N-PLAY MODULES ONLY: The wiring colors on our Illuminator Modules are defined in the color chart below. The fused ORANGE wire on our module needs 12-volt (+) positive battery power.

HARD-WIRED INSTALLATION: On the hard-wired version, you can use any installation method you choose but **DISCONNECT** the battery **FIRST!** We package this version with butt connectors and quick splices but recommend using connectors and terminals whenever possible. Now let's talk about the input and output wires. When we say "INPUT" we are referring to the wires that are currently running to your REAR left and right turn signals and your taillight, (*running and brake light*). This is called your rear fender harness and these wires are needed to feed the input wires on the module. Once hooked up, (*see wiring diagram below*) the input wires will provide all of the functions the module needs to process RUN/BRAKE/TURN signal functions onto the OUTPUT wires. The objective of the diagram below is to show you to "splice into" the running light, and brake light wires using quick splices while still keeping these wires attached as they were from the factory. Only the BLUE/VIOLET (*left turn signal*) and BLUE/BROWN (*right turn signal*) wires should be cut. The feed side of these wires (*from the front of the bike*) should be attached to the BLUE/VIOLET and BLUE/BROWN wires on the module using supplied butt connectors. The other half of the cut blue/violet and blue/brown wires should be connected to the GRAY and YELLOW wires on the module using supplied butt connectors. Be sure to test when complete.

PLUG-N-PLAY INSTALLATION: Most of our modules offer Plug-n-Play technology, making installation quick and easy. Simply remove your seat, unplug the rear fender harness connectors, plug our module in between and you're done. (*see below for fitment*)

ILL-CB: Hard-wired module, universal fitment, comes complete with (1) 1/4" ring terminal if you decide to install the modules BLACK wire directly to frame ground or (-) battery post, (1) 1/4" ring terminal for connecting the ORANGE power wire directly to battery post with a 7.5-AMP fuse, (2) quick splices for RED and BLUE wires on the module for running and brake lights and (4) butt connectors for right and left turn signal inputs and outputs.

ILL-CB-A: Plug-n-Play module, fits (2011-Up Softail, 2012 Dyna, FXDF, FXDB/P, FXDWG, FLD, FXDC/L, FLSTC, FLSTF/B, FLSTN, FXST) This module comes with an 8-position male and female Multilock connector that connects in between your rear fender connection under the seat.

ILL-CB-B: Plug-n-Play module, fits (All 2014-Up XL Models with Single Center Stop Lamp LED or Bulb) This module comes with (2) 4-position male and female Mini-Multilock connectors and (1) 3-position that connects in between your rear fender connection under the seat.

ILL-CB-C: Plug-n-Play module, fits (2014-Up Road King & Police Bike ONLY) This module comes with a 6-position male and female Molex connector that connects in between your rear fender connection under the seat.

