

## Items Supplied >

- 1 – FREEWAY BAR
- 2 – BOLT, BUTTONHEAD 3/8"-16 X 1"
- 2 – NUT, NYLOCK 3/8"-16
- 2 – 3/8" FLAT WASHER
- 1 – BOLT, BUTTONHEAD 5/16"-18 X 3/4"
- 1 – NUT, NYLOCK 5/16"-18
- 1 – 5/16 FLAT WASHER

## Application(s) >

HARLEY  
HERITAGE SOFTAIL CLASSIC 2000-2014

## Instruction Manual >

601-2105 / 601-2205

Page 1 of 1

**Read all instructions carefully before installing your new Cobra® product!**

1. Remove any accessories that may prohibit the installation of your new freeway bar.
2. Position the freeway bar into place between the down tube frame rails and front tire. Align the holes in the freeway bar's lower mounts with the open holes on the floorboard frame mounts. Insert the (2) supplied 3/8"-16 x 1" buttonhead bolts thru floorboard frame mounts and lower freeway bar mounts; secure with supplied 3/8" flat washers and nylock nuts. See Diagrams. **DO NOT FULLY TIGHTEN.**
3. Rotate the freeway bar up and back then align the hole in the frame brace with the freeway bar's upper mount. Insert the supplied 5/16"-18 x 3/4" buttonhead bolt thru freeway bar mount and into frame brace and secure on the backside with the supplied 5/16" flat washer and 5/16"-18 nylock nut. **DO NOT FULLY TIGHTEN.**
4. Make sure freeway bar is aligned properly then fully tighten the 5/16"-18" bolt and nut followed by the 3/8"-16 bolts and nuts.

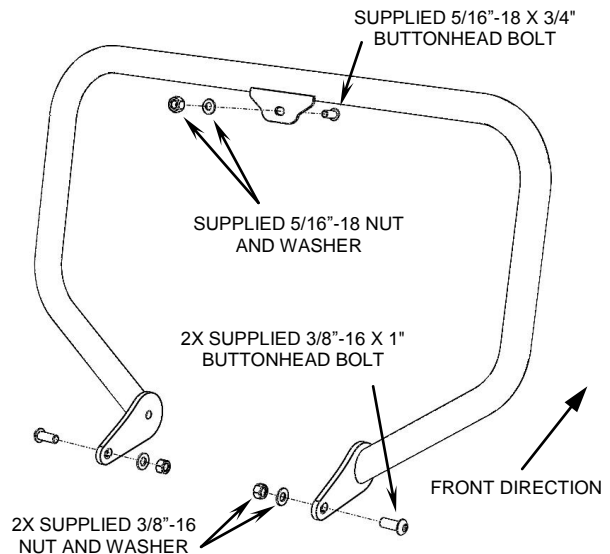
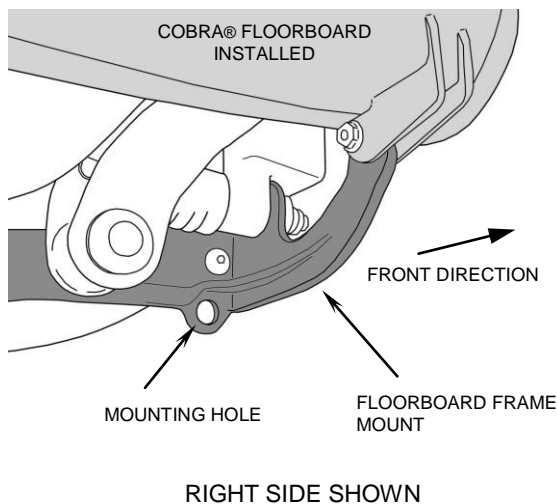

**Cobra Freeway Bars add style to your motorcycle. They are not designed to withstand a serious impact and may not protect you and/or your motorcycle in the event of a crash.**

*\*Cobra® recommends you always wear a helmet while riding. Please never operate your motorcycle while under the influence of alcohol and/or drugs. Enjoy the new look of your motorcycle and please ride safely.*