



FEULING®



OIL PUMP INSTALLATION INSTRUCTIONS

FOR H-D TWIN CAM ENGINES

PART # 7000, 7050 '99 - '06 EXCEPT '06 DYNA T/C MODELS
PART # 7060, 7062 '07 - '10 T/C MODELS INCLUDING '06 DYNA



OIL IS THE LIFE-BLOOD OF YOUR ENGINE. DON'T TAKE OFF WITHOUT IT!

THE FEULING HIGH VOLUME OIL PUMPS UTILIZE AN OVERSIZED AND HIGHLY EFFICIENT GEROTOR GEAR DESIGN, PROVIDING AN INCREASE IN PRESSURE PUMP VOLUME AND AN INCREASE IN SCAVENGE (RETURN) VOLUME. THE FEULING OIL PUMPS ELIMINATE WET SUMPING, BLOW-BY AND OILY AIR CLEANER PROBLEMS AND PROVIDE HIGH VOLUME OIL FLOW FOR OPTIMUM LUBRICATION AND COOLING. THE FEULING OIL PUMPS WILL ALLOW USE OF FEULING HIGH FLOW LIFTERS FOR CRITICAL, FULL FLOW TOP END LUBRICATION.

IMPORTANT NOTICE

THIS INSTALLATION SHOULD BE DONE BY AN EXPERIENCED MECHANIC WHO HAS ACCESS TO A FACTORY SERVICE MANUAL AND ALL REQUIRED TOOLS.

CAUTION

INCORRECT INSTALLATION CAN CAUSE ENGINE DAMAGE NOT COVERED UNDER WARRANTY. FAILURE TO INSTALL COMPONENTS CORRECTLY CAN CAUSE ENGINE SEIZURE. WHICH MAY RESULT IN SERIOUS INJURY TO MOTORCYCLE, OPERATOR, PASSENGER, AND/OR OTHERS.

IMPORTANT NOTICE

MEASURE FLYWHEEL PINION SHAFT RUN OUT. EXCESSIVE PINION SHAFT RUN OUT WILL CAUSE CAMPLATE AND OIL PUMP DAMAGE AND OR FAILURE. EXCESSIVE PINION SHAFT RUN OUT WILL VOID MANUFACTURER'S WARRANTY.

* THE SUB SEAL IS NOW INSTALLED INTO THE BACK OF THE OIL PUMP AT THE FACTORY WITH AN INTERFERENCE PRESS FIT, ELIMINATING THE SMALL O-RING ON THE SMALL END OF THE SUB SEAL.

1. Refer to H-D manual, engine section, reference sub assembly service and repair bottom end, for removal of camplate, stock oil pump, cams and cam bearings. Refer to H-D manual engine section, reference oil pressure relief valve, for removal of the oil pressure relief valve and valve spring from the camplate.
2. Inspect flywheels for pinion shaft run out. Feuling recommends a maximum run out tolerance of 0.0025". If installing gear drive camshafts the run out tolerance is very important, it is advisable to be under the maximum tolerance.
3. **WASH AND CLEAN CAMPLATE THOROUGHLY.** Inspect for scoring on oil pump mounting surface, any scoring will adversely effect oiling system operation. On '99 - '06 Except '06 Dyna models, inspect cam bearing bores for proper bearing fit.
4. Clean and flush oil tank, any residue/debris in oil tank will flow directly through the newly installed oil pump.
5. Inspect pressure relief valve plunger for burrs and debris. The plunger must move freely and seat properly. With the stock camplate, measure length of the stock pressure relief spring. Stretch spring to measure .050" longer than the stock length. Most aftermarket camplates come with a stiffer spring. Feuling tool part #9010 can be used to bench test and set the camplates pressure relief pop off psi.
6. Re-install pressure relief valve and spring in camplate according to H-D manual.
7. Install clean cam bearings and cams into camplate, '99 - '06 Except '06 Dyna. Reference H-D manual for assembly of stock cam chain drive system. Reference gear drive camshaft installation instructions where applicable.

CHECK CRANK RUN OUT



Dial indicator W/
Magnetic base

Max run out 0.0025"



Feuling Runout Measuring
Tool #9010

INSPECT CAMPLATE PRESSURE RELIEF VALVE



Verify the pressure relief valve
moves freely. Any leakage @
the valve will cause
a loss of oil pressure



Feuling camplate
pressure test tool
9010

INSPECT CAMPLATE FOR SCORING



Scoring between the kidney shapes
will cause low oil pressure and
oil system cavitation problems

FEULING OIL PUMP REBUILD KIT INSTRUCTIONS

PART # 7001 REBUILD KIT FOR OIL PUMPS #7000, 7050

PART # 7061 REBUILD KIT FOR OIL PUMPS #7060, 7062

1. Disassemble Feuling Oil Pump, wash and clean all components.
2. Inspect oil pump gears and oil pump housings, if scoring is present and can be felt with fingernail, the gears and housing must be replaced as a set. The Feuling oil pump gears and oil pump housings are matched as sets and the stack up tolerance is crucial to proper operation. The Feuling stack up tolerance is 0.0015" - 0.002" - thickness difference between the gears and aluminum housing. This must be measured accurately using a micrometer.
3. Inspect camplate oil pump mounting surface , if scoring is present on camplate and can be felt with fingernail the camplate must be replaced.
4. Inspect camplate pressure relief valve. The valve must move freely in bore and seat properly. We recommend pressure testing camplate with Feuling psi test tool part #9010. Leakage at the camplate pressure relief valve will result in a loss of oil pressure.
5. Measure Pinion shaft run out. Feuling recommends a maximum run tolerance of 0.0025". Note *run out will not get better with miles
6. Re-assemble the Feuling oil pump following oil pump instructions.
7. If gears and housings need to be replaced contact Feuling with part #'s. If the housing is free from scoring and only the gears have minor scoring the gears can be resurfaced and re-matched to the housing as a set by the Feuling warranty department. Ph. 619-917-6222

Feuling Returns Department - 17215 Roper Street - Mojave, CA 93501 - Ph. 619-917-6222 - www.FeulingParts.com

TROUBLE SHOOTING

LOW OIL PRESSURE

Pressure gauge not reading properly – double check with another mechanical PSI gauge
Pressure relief valve in camplate sticking or not seating properly – see Feuling camplate PSI test tool Part #9010
Camplate scored at oil pump mounting surface, Pressure gears and or housing scored from debris running through oil pump
Camplate top plug not sealing, Camplate leaking at oil passages – warped camplate
Pinched O-ring(s)
Excessive run out in pinion shaft
Miss alignment – center camplate to pinion shaft then oil pump to pinion shaft by rotating engine over

NO OIL PRESSURE

Air lock – fill oil filter full of oil
Pressure relief valve stuck open in camplate – see Feuling camplate PSI test tool Part #9010
Missing plug in camplate face (boss vs. no boss)
Broken gears - Gears & housings not lubricated properly during install, excessive run out in pinion shaft
Broken/Leaky piston cooling jets

WET SUMPING / BLOW - BY

To verify if engine is wet sumping, run engine to operating temp. then shut down and pull the allen head plug from bottom of engine case. Measure oil - and if more than 5oz. drains then there is a wet sumping issue.
Sub seal of oil pump miss aligned with scavenge port hole of engine case
Rings not seated or excessive leak down through rings and cylinders, run a leak down test - Vent oil tank - see Feuling's oil tank breather kits
Oil level too high
Scavenge gears and or housing scored from debris running through oil pump, Out of tolerance scavenge side of oil pump
Excessive run out in pinion shaft creating cavitation
Return oil passages plugged, Pick-up hole in crankcase plugged
Pinched O-ring(s)
FLT – 6 speed trans with dipstick in rear of trans can allow more oil to be added to oil tank and not show on dipstick
Excessive RPM on rev limiter or detonation/spark knock de-seating rings
Flapper valves in breathers stuck
Incorrect bottom rocker box gasket blocking breather ports

DIPSTICK BLOW OUT

Excessive cylinder/ring leak down – run a cylinder leak down test
Oil level too high, run oil level 3/4 full cold
Rocker housing gaskets wrong or installed improperly
Detonation, rings not seated or coming un seated under hard acceleration
Vent oil tank – see Feuling oil tank breather kits

NOISY VALVE-TRAIN

Pushrods hitting pushrod tubes, inspect your rods for ring witness mark around pushrod normally seen towards the cylinder head meaning your rods are flexing, spinning creating contact causing noise and a loss of valve lift
Lifter bore to lifter body clearance too large, Feuling recommends a clearance of 0.001" - 0.0015" for proper lifter performance
Leaky/broken piston cooling jets
Pushrod oil hole plugged
Clearance for roller rocker arms on under side of rocker box cover
Rocker arm bushing to rocker arm shaft clearance
Valve Spring separation or valve spring coil bind, recommend replace and match valve springs to camshafts

Oil Pump Assembly Parts List

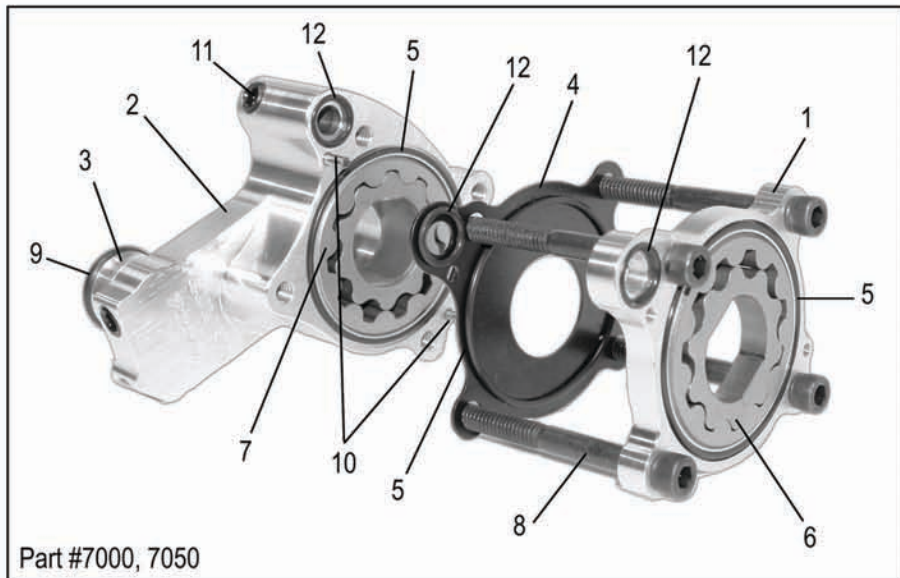

Part #7000, 7050

<u>Ref. #</u>	<u>Description</u>	<u>Qty.</u>	<u>Part #</u>
1	Pressure Pump Housing #7000	1	7000-01
1	Pressure Pump Housing #7050	1	7050-01
2	Scavenge Pump Housing #7000	1	7000-02
2	Scavenge Pump Housing #7050	1	7050-02
3	Sub Seal	1	7000-03
4	Separator Plate	1	7000-04
5	O-Ring - Large	3	7000-05
6	Pressure Gerotor Set	1	7000-06
7	Scavenge Gerotor Set	1	7000-07
8	Bolts 1/4" x 1 1/4"	4	7000-08
9	O-Ring, Sub Seal	1	7000-09
10	Dowel Pin, 1/8" x 3/4"	2	7000-10
11	Plug, 3/8" - 24	3	7000-11
12	O-Ring - Small	3	7000-12
	Rebuild Kit Pumps #7000, 7050	1	7001

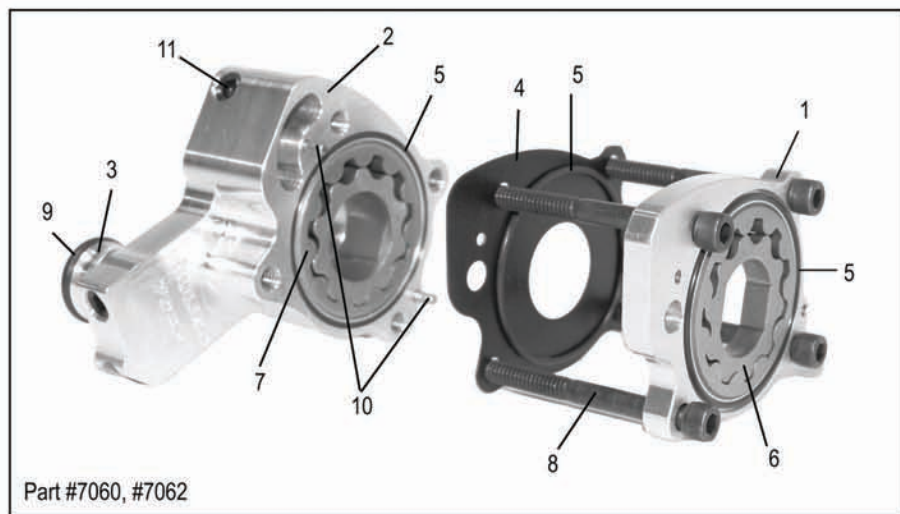

Part #7060, #7062

<u>Ref. #</u>	<u>Description</u>	<u>Qty.</u>	<u>Part #</u>
1	Pressure Pump Housing #7060	1	7060-01
1	Pressure Pump Housing #7050	1	7062-01
2	Scavenge Pump Housing #7060	1	7060-02
2	Scavenge Pump Housing #7062	1	7062-02
3	Sub Seal	1	7000-03
4	Separator Plate	1	7060-04
5	O-Ring - Large	3	7000-05
6	Pressure Gerotor Set	1	7000-06
7	Scavenge Gerotor Set	1	7000-07
8	Bolts 1/4" x 1 1/4"	4	7000-08
9	O-Ring, Sub Seal	1	7000-09
10	Dowel Pin, 1/8" x 3/4"	2	7000-10
11	Plug, 3/8" - 24	3	7000-11
	Rebuild Kit Pumps #7060, 7062	1	7061

WARRANTY:

All parts are guaranteed to the original purchaser to be free of manufacturing defects in materials and workmanship for a period of twelve (12) months from the date of purchase. Merchandise that fails to conform to these conditions will be repaired or replaced at FOP's option if the parts are returned to FOP by the purchaser within the (12) month warranty period.

In the event warranty service is required, the original purchaser must notify FOP of the problem immediately. Some problems may be rectified by a telephone call and need no further action. A part that is suspect of being defective must not be replaced without prior authorization from FOP. If it is deemed necessary for FOP to make an evaluation to determine whether the part was defective, it must be packaged properly to avoid further damage, and be returned prepaid to FOP with a copy of the original invoice of purchase and a detailed letter outlining the nature of the problem, how the part was used and the circumstances at the time of failure. After an evaluation has been made by FOP and the part was found to be defective, repair, replacement or refund will be granted.

Excessive flywheel pinion shaft run out will damage camplate and oil pump and or cause engine damage and or failure. Damage to Feuling oil pump corporation products from excessive pinion shaft run out and or valve spring coil bind or valve spring separation will void manufacturer's warranty.

ADDITIONAL WARRANTY PROVISIONS:

FOP shall have no obligation in the event an FOP part is modified by any other person or organization, or if another manufacturer's part is substituted for one provided by FOP. FOP shall have no obligation if an FOP part becomes defective in whole or in part as a result of improper installation, improper break-in or maintenance, improper use, abnormal operation, or any other misuse or mistreatment.

FOP shall not be liable for any consequential or incidental damages resulting from the failure of an FOP part, the breach of any warranties, the failure to deliver, delay in delivery, delivery in non-conforming condition, or any other breach of contract or duty between FOP and the customer.

The installation of parts may void or otherwise adversely affect your factory warranty. In addition, such installation and use may violate certain federal, state and local laws, rules and ordinances as well as other laws when used on motor vehicles operated on public highways, especially in states where pollution laws may apply. Always check with federal, state, and local laws before modifying your motorcycle. It is the sole and exclusive responsibility of the user to determine the suitability of the product for his/her use, and the user shall assume all legal, personal injury risk and liability and all other obligations, duties and risks associated therewith. Our high performance parts, engines and motorcycles are intended for experienced riders only. Feuling Oil Pump Corporation reserves the right to change prices and/or discounts without notice and to bill at the prevailing prices at the time of shipments.

The words Harley®, Harley-Davidson® and H-D® and all H-D® part numbers and model designations are used in reference only. Feuling Oil Pump Corporation is in no way associated with, or authorized by Harley-Davidson Motor Co®. to manufacture and sell any of the engine parts described in this instruction sheet.

8. Reference the Oil Pump Assembly Parts Lists and Photos to verify all the proper components for the Feuling Oil Pump.
9. **WASH, AND CLEAN OIL PUMP THOROUGHLY**, inspect each individual part of the Feuling oil pump. Verify the oil pump has 3 Allen-plugs in the scavenge housing.
10. The O-rings supplied **ARE** the correct size. If required, gently stretch O-rings to fit in machined O-ring groove. **Extra O-rings** are included. Grease can be used to help hold the O-rings in proper position for installation. **DO NOT USE** a hardening compound to hold O-rings, the compound will interfere with stack up tolerance and the pump will not work properly.
11. Assemble oil pump, install O-ring(s) into proper grooves of the scavenge pump housing.
12. Install O-ring(s) into proper grooves on both sides of pressure pump housing.
13. Install the two supplied dowel pins into pin holes on **SCAVENGE** pump housing to ensure proper alignment of the pump housings.
14. Apply engine assembly lube to both sets of Gerotor gears and pump housings.
15. Install gears into proper housing.
16. Position separator plate over dowel pins on scavenge housing.
17. Position pressure pump housing onto dowel pins on top of separator plate on the scavenge pump housing.
18. Install proper O-ring on large end of the sub seal. Liberally lube the O-ring and scavenge port hole of engine case.



19. Bolt oil pump to camplate. We recommend laying oil pump on bench with pressure gears facing up, set camplate onto oil pump then install oil pump bolts finger tight.

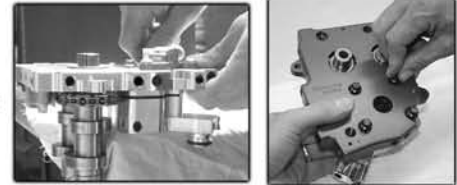

20. Use engine oil or assembly lube, **DO NOT USE LOCTITE OR HARDENING** compound on the oil pump or camplate bolts, it will interfere with the stack up tolerance, causing low oil pressure or poor scavenging.



21. Thread bolts finger tight into the oil pump. Do not tighten.

22. Check O-rings for proper installation.

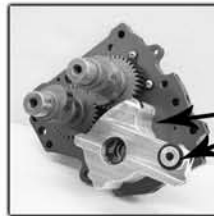

Verify all the O-rings are installed correctly

23. Slide the complete oil pump/camplate assembly onto the crankshaft, align the oil pump gear flats with the crankshaft flats to ease installation. Using slight pressure slip oil pump sub seal into scavenge port hole of crankcase (it's helpful to use pressure from your thumb to push on scavenge housing to ensure proper fit into case scavenge port hole), at the same time wiggle assembly to align camplate with dowel pins in engine case.

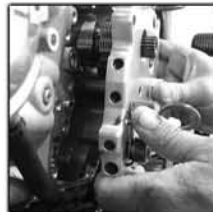

Install Camplate & Oil pump as a complete assembly

24. Tighten camplate bolts first - finger tight, with camplate bolts finger tight, rotate engine over several times, this will center the camplate to the crankshaft. Alternately tighten all camplate bolts to 10 inch lbs. Then rotate engine over again and final torque the camplate bolts to 90-120 inch lbs.

25. With oil pump bolts only finger tight, rotate engine over several times. This will center the oil pump and gears to the crankshaft. This process eliminates the need for the 'centering pins'. Alternately tighten the four oil pump bolts to 10 inch lbs. Rotate engine again then final torque the oil pump bolts to 90-120 inch lbs.

26. Final torque on pump and camplate bolts should be 90-120 inch lbs.



27. Refer to H-D manual for final assembly.