



HogLIGHTS

CAN YOU SEE ME NOW
ARSEHOLE!

Fat Bob Installation Instructions

Tools you will need:

- 3/32 Allen Key
- HogLights Fat Bob LED Headlights
- HogLights Fat Bob wiring harness
- 2 ½ beers (or whatever you prefer to drink)

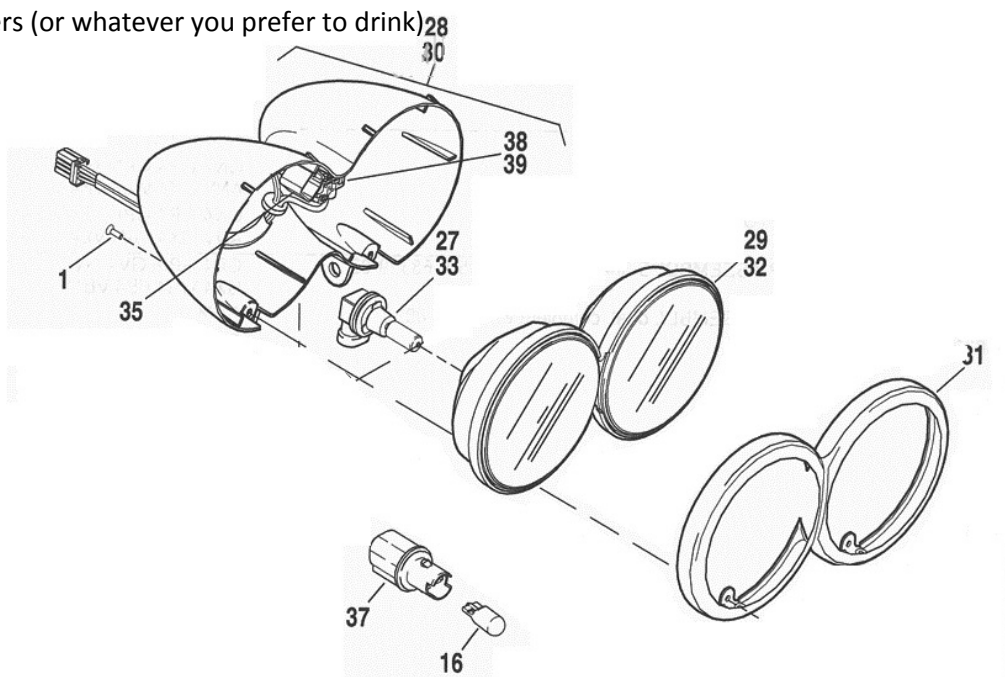

1. Using the 3/32 Allen Key, remove the two screws (item #1), one each side.
2. Pull forward, from the bottom, the headlight trim ring (item #31), slowly so as not to damage any paint work.
3. Remove the internal headlight assembly (item #29/32).
4. Unplug the headlight wiring harness (item #38/39) from the internal headlight assembly.
5. Remove the parker bulb from the harness (item #16) – put aside as this is not required.
6. Connect the HogLights wiring kit (not shown) to the harness (items #38/39). Ensure you match the wires on both side of the plugs (yellow -> yellow, white -> white, black -> black).
7. Connect the HogLights wiring kit to the individual LED lights (not shown).
8. Install the LED lights into the light bucket (item 28/30). To ensure correct fitment and orientation, ensure the “**oval**” lights are at on the **bottom**. Spread the harness between the two buckets, to ensure the lights fit snugly. It is a tight fit, ensure you push the lights into place.
9. Starting from the bottom, carefully place the headlight trim (item #31) back onto the bucket.
10. Replace screws (item #1) into bottom of the headlight trim ring (item #31)
11. Sit back, relax and enjoy the rest of your drink!



HogLIGHTS

CAN YOU SEE ME NOW
ARSEHOLE!

Condensation in your Lights

Condensation is a naturally occurring condition that can affect any light. It does not suggest a defect in a product, as opposed to what happens when a leak occurs, in which case there is water ingress that could lead to a system failure. The explanation below is intended to help you differentiate between these two conditions so you understand what, if anything, needs to be done.



Condensation

Condensation is the change of water from a gaseous form (vapor) into liquid water. It appears as small droplets of moisture inside the light.

Condensation does not cause a problem with normal operation of the light and is, therefore, NOT considered to be a defect or warrantable condition.

In fact, HogLights lamps are designed to allow moisture to escape and not re-enter, but it takes time for the moisture to evaporate (the amount of time will depend upon whether or not the light is turned on or not).



Water Ingress

Water ingress describes water that leaks into the light, manifesting itself as large droplets or pooling of water that is clearly visible. Sources of water ingress can vary.

If a light suffers water ingress as the result of physical abuse and/or misuse, it would not constitute a manufacturing defect.

Otherwise, water ingress caused by a defect in workmanship is a warrantable item. In this event, please contact us or the dealer who supplied the product to schedule a return.

To assist with your return, please photograph the water, as clearly as possible then email to support@hoglights.com.au

Virtually all lights are prone to condensate due to the following events:

- Air is trapped inside a lamp when manufactured;
- Plastic parts used in lights naturally absorb moisture in the air;
- As the light heats up these plastic parts release moisture that mixes with air;
- Moisture attaches itself to the coolest part of the lamp, e.g. the lens;
- Halogen lamps tend to run hot so the moisture evaporates more quickly;
- LED lights produce less heat so moisture takes longer to evaporate, so it can be more noticeable

We hope you enjoy our products and have many years of great use from them.