

# HOGTUNES

*Audio Solutions For The Great American Cruiser*



## 692 RETRO LID-XL

**CUT-IN LID KIT WITH 6" x 9" SPEAKERS**

*2014+ RUSHMORE MODEL BIKES WITH FACTORY STYLE HARD SADDLEBAGS*

**INSTALLATION MANUAL**

Thank you for choosing Hogtunes 692 Retro Lid-XL for 2014+ touring bikes with factory saddlebag lids. Since positive word of mouth is the best way to grow our business, we want your new parts to work as well as they were designed to. If you have any questions or concerns, we are here to help. Email [techsupport@hogtunes.com](mailto:techsupport@hogtunes.com), or call us during regular business hours. If you still need help, please consider a professional install.

### **Hogtunes Contact Information**

Email: [techsupport@hogtunes.com](mailto:techsupport@hogtunes.com)

USA Tel: 608-554-7631 - Canada Tel: 705-719-6361

## **IMPORTANT NOTES**

- 1) The speakers in this kit are 2  $\Omega$  (ohms) and must be powered by a 2 ohm stable power source
- 2) These speakers will work off a 2 ohm stable radio however an amplifier is strongly suggested for best performance
- 3) This manual is written assuming the amp that will power the supplied speakers is located inside the fairing



**DO NOT USE "THREAD LOCK" OR "SCREW GLUE" OF ANY KIND AS IT DESTROYS PLASTIC AND WILL CAUSE PART FAILURE NOT COVERED BY WARRANTY!**

## **REPLACEMENT PARTS**

Accidents happen, and we get a lot of requests for replacement parts for all of our kits. If you find yourself needing a grill or a badge, or any other part, please visit the "Parts and Accessories" section of our website at [www.hogtunes.com](http://www.hogtunes.com) or call us!

# GETTING STARTED

Remove the saddlebag from the bike, and put on a stable working surface. For obvious reasons, blankets etc. on your work surface will help protect the paint. The white circle in Fig 1.1 is an approximation of where a 5/8" (16mm) hole will be drilled. This hole is where the supplied Houghtunes silicone grommet will go to allow the lids speaker wire to pass into the saddlebag. We strongly suggest putting masking tape over the painted area to be drilled. We also suggest starting with a small bit, and gradually working your way up to the 5/8" (16mm) hole. Drilling the hole with the lid still on is recommended! Locate the wire harness and take the 48" section with the silicone grommet in line and install into the saddle bag making sure the 2 speaker "spades" are on the inside of the bag, and the single 2 pin connector is on the outside of the bag. The black squares (also in Fig 1.1) are an approximation of where supplied zip tie peel and stick "anchors" will be placed. Note: Before applying the anchors, you need to clean the plastic **WELL** using 99% isopropyl alcohol, or similar cleaner. **DO NOT use Acetone (It will eat plastic)**. Do not apply pads until cleaner has completely evaporated.



Figure 1.1

# IDENTIFYING THE SCREWS

The kit comes with 2 types of screws:

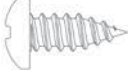
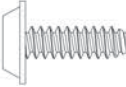
- 6 (each) Phillips head screws with a pointy end 
- 16 (each) Phillips "Thread Forming" screws with a "flat" end 

For proper installation of this kit, you will need to use the correct screws throughout the process.

## DISASSEMBLING THE FACTORY LID

As you disassemble your factory lid, please make note of what screws came from where as they will be re-used. Open the factory lid and you will see 2 "T15" torx screws on the "bag side" of the cloth tether that holds the lid to the bag. Remove these 2 screws, move the cloth tether out of the way, and you will see 2 more of the same screws which also need to be removed. The lid is now free from the bag. Remove the 2 screws that hold the "key lock" to the factory lid. The chrome panel with the reflector built in comes off the factory lid by removing the 3 screws right next to the key lock. At its seam, the factory foam gasket needs to be peeled up enough to allow the rest of the hinge mechanism to be removed from the factory lid. There are 2x "T20" torx screws that hold the balance of the hinge mechanism to the plastic of the lid. Remove these screws and put hinge mechanism aside.

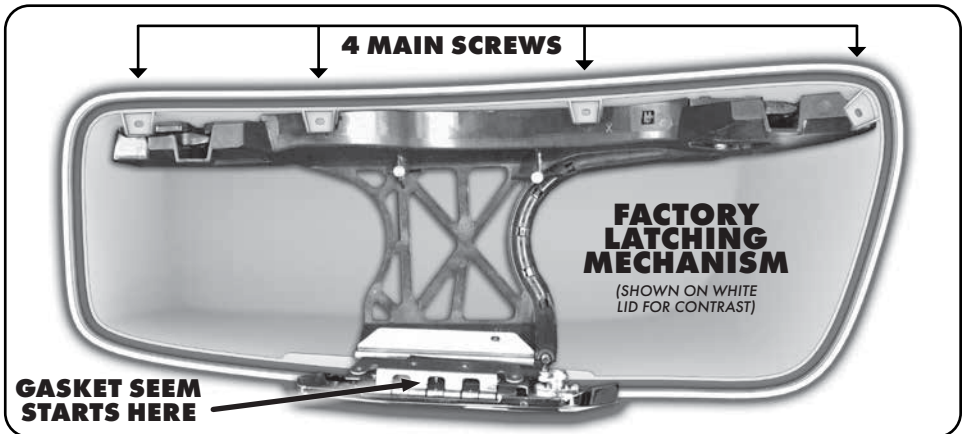

Remove the T15 screw that holds the opening handle in place and pull the handle away from the factory lid. Remove the last 4x T15 screws securing the large latching mechanism to the underside of the factory lid. This entire mechanism is now removed.

# MOUNTING THE TEMPLATES

- Step #1: Locate the cutting templates noting that they are clearly marked "Clutch side" and "Brake side". As shown in Fig 1.4, apply masking tape to the underside of the template to avoid unnecessary scratches to the lids paint.
- Step #2: Using Fig 1.3, put the correct template on the correct lid and drill through the 3 holes in the template using a 1/8" (3mm) drill bit. Locate 3 of the supplied "pointy" ended screws and using hand tools, secure the template to the lid. You will also see "keyhole" shapes in each template where you will start to cut when its time. Drill a 1/8" (3mm) "starter hole" in each of these key holes and then enlarge these holes to 5/16" (8mm)
- Step #3: Using a scratch awl or a pick tool (or something similar), scratch the factory paint all the way around the outer most area of the "cut line". This gives you a line you can use "just in case" you need to trim your lid once your cutting is complete.

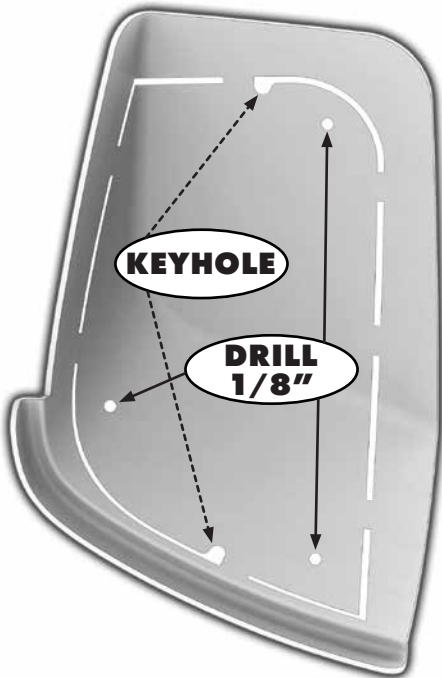

Figure 1.3

Underside of Template  
No Masking Tape



Figure 1.4

Underside of Template With Masking  
Tape Applied Around Perimeter

# PRO TIP

We **STRONGLY** suggest using a blade **SPECIFICALLY MADE FOR PLASTICS!**

When cutting your lid with a correct blade, there should be ZERO smell of burning plastic! Incorrect blades will do more melting than cutting and your friends may laugh at you hysterically.

## CUT GRILL OPENING

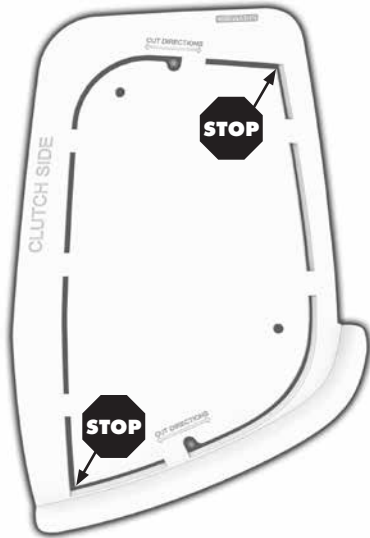

Its time to start cutting. We suggest a standard jigsaw or an air "body" saw. In all cases, you will **start at one of the "keyholes"** in the template, and **stop at the "hard corners"** as shown.

Make sure to cut through all the tabs in the template. We suggest starting at the keyhole closest to the middle of the lid first. Once the template is free from the lid, it can be discarded. You will now see the line you scribed in case you need to do any trimming before proceeding.

## TEST FIT GRILL

You can now test fit the grill to see if it fits nicely in the opening. Trim as needed being careful not to damage your painted surface. Once you are satisfied everything fits nice, re-install the lids latching mechanism. Don't put the lids on the bags yet.



## CLUTCH SIDE LID

---



Have the lid upside down on a blanket or something similar to protect your painted surface. Locate the speaker adaptor marked "Clutch" noting you will see it only fits one way. In the order shown, you will put "thread forming" screws through the adaptor and into the grill so the pieces "sandwich" the opening. **MAKE SURE to put a supplied rubber washer on screw #4!** Using *hand tools*, get each screw started. Once started, tighten each one down till they "stop". They don't need to be any tighter than that and will damage the rubber washer and cause leaking.

## BRAKE SIDE LID

---



Have the lid upside down on a blanket or something similar to protect your painted surface. Locate the speaker adaptor marked "Brake" noting you will see it only fits one way. In the order shown, you will put "thread forming" screws through the adaptor and into the grill so the pieces "sandwich" the opening. **MAKE SURE to put a supplied rubber washer on screw #4!** Using *hand tools*, get each screw started. Once started, tighten each one down till they "stop". They don't need to be any tighter than that and will damage the rubber washer and cause leaking.

The silicone gaskets included in the 692-XL box are not used for this installation. The silicone speaker gasket supplied in the "Retro Lid-RM" has a "flat side" and a "groove" side. You will put the flat side against the adaptor so your speaker sits on to the groove side. Using the supplied "thread cutting" screws, attach the 692-XL speakers to the adaptors noting which way the speaker wire connectors are for easy access once inside the bag. Plug the wires onto the speakers noting they will only go on one way. You can now use the supplied peel and stick zip tie "anchors" to secure the wires inside your bag.

## **LEAVE EXTRA SLACK SO THE LID CAN OPEN!**

Note: Before applying the anchors, you need to clean the plastic WELL using 99% isopropyl alcohol, or similar cleaner. **DO NOT use Acetone** (It will eat plastic). Do not apply pads until cleaner is completely evaporated.

- With the anchors in place, secure the wires in place using supplied zip ties.
- With the speakers attached to your lids, re-attach the lids to your saddle bags and re-install the completed bags to the bike.



# WIRING FROM AMPLIFIER TO SADDLEBAGS

The long supplied wire harness covered in braid with 4 wires has 2-2 pin plugs on one end, and a single 4 pin plug on the other. In all cases, the end with the 4 pin plug will go nearest the amp you're using which typically will be your fairing. For FLH (Batwing) Models, the harness will pass under the inner fairing where the main wire harness passes through on the clutch side of the bike. For FLTR (Road Glide) Models, the harness will pass through the inner fairing where the factory wires pass. Loosen the tank console and run wires up and over the gas tank, but under the tank console. There is a provision on the front of the tank console for wires to pass. **Note: You "can" lift the fuel tank and run the wires in the factory "chase" on the top of the frame if you want but it is not required.**

The other end of the harness will stop just behind the battery. You can now plug the wires from each saddlebag into the main harness noting each pair of wires is marked "clutch side" and "brake side" for reference. Undo the quick release fasteners used to secure the bag to the bike so the bag can lean away from the bike allowing you to access the wires on the back side of the bag installed earlier. The wire will go upwards and be secured to the peel and stick "anchors" using supplied zip ties. **IMPORTANT: Any slack in the speaker wires between the bike and the bags MUST be secured under the seat to eliminate the chance the wires could become tangled in the bikes moving parts when riding!**

The 4 pin connector on the wire harness will plug into any Hogtunes "REV" series amp, or any Wild Boar Audio amp. If your using another brand of amp, you will see that the wires near the 4 pin are labeled. Simply cut the plug off and wire the lids to your amp using the labels to identify each wire.

# GRILL BADGE OPTION

The grills come with a pre-installed badge with chrome letters. Depending on the bike, you may want to remove these badges and use the supplied blacked out badges. To remove the badges, you can use a 90 degree pick tool or a small flat head screwdriver or something similar to **CAREFULLY** pry the badges off. Before putting the new badges on, make sure there is no left over adhesive residue from the first set. If there is, use something like isopropyl alcohol to clean the residue off. **DO NOT use Acetone (It will ruin the grill finish).** Make sure the cleaner is completely evaporated before applying new badges.

To apply the new badges, simply peel off the backing to expose the adhesive. Sit the badges in place. **IMPORTANT: the new adhesive should sit at room temp (or higher) for 24 hours minimum for the adhesive to "bite in" to the grill surface.**

*Before re-installing outer fairing, turn front wheel to each extreme side making sure any wiring is not impeding the steering of the motorcycle.*

*Failure to do so can result in serious injury or death!*

*Harley-Davidson, Electra Glide, Road Glide, Street Glide, Ultra Classic, Tri Glide, CVO, Screamin Eagle and Tour-Pak® are Trademarks, and/or Registered Trademarks of Harley-Davidson, Inc., Milwaukee, Wisconsin, USA, and if Used or Implied are for Reference Only. There is No Affiliation Between Harley-Davidson, Inc., and Hogtunes Inc.*

# WARRANTY INFO

Hogtunes 692 XL Series speakers are warranted for a period of 5 years to the original purchaser. Hogtunes Retro LID-RM are warranted against defects out of the box only. Proof of purchase is required for all warranty claims.

**Warranty claims are handled directly with Hogtunes.**

Products found to be defective during the warranty period will be replaced (with a product deemed to be equivalent) at Hogtunes' sole discretion. Hogtunes complete warranty policy is available on the Hogtunes website.

**What Is Not Covered:**

- 1) Any expense related to the removal or re-installation of Hogtunes products.
- 2) Paint applied to any part, for any reason.
- 3) Damage from fasteners piercing through or being over tightened.
- 4) Repairs to these products performed by anyone other than Hogtunes.
- 5) Subsequent damage to any other components.
- 6) Any product purchased from a non-authorized Hogtunes dealer.
- 7) Damage to Hogtunes products due to an accident or collision.
- 8) Damage from use of Thread lock/Screw Glue materials of any kind.

**IMPORTANT: In the event of a warranty claim, please fill out the form in the Warranty section of our website, or contact us by email or by phone. Valid claims will have a Return Authorization Number (RA#) generated which MUST appear on the outside of the box when it arrives to our offices.**

**Goods Arriving Without An RA# Will Be Refused!**

**PRACTICE  
SAFE  
SOUND!**

Hogtunes products will play much louder than the Original Equipment, which can be a distraction to the rider and/or passenger. Please use caution when adjusting, or playing your stereo at high volume, **ESPECIALLY IN TRAFFIC.**

*You are a valued customer so please:*

**Ride Alert  
Arrive Alive!**

**HOGTUNES**

**HOGTUNES INC. FAMILY OF BRANDS**

**HOGTUNES**  
Audio Solutions For The Great American Cruiser

  
**WILD BOAR**  
AUDIO

  
100 LEVEL SPEAKER  
HOGTUNES  
EST. 2006  
DESIGNED FOR A MOTORCYCLE

  
**METRIX**  
AUDIO

[www.hogtunes.com](http://www.hogtunes.com)