



---

## **MC615R AIR LIFT MANUAL**

---



***K&L SUPPLY CO., INC***

*1040 Richard Avenue Santa Clara, CA USA 95050*

*TEL: 1-800-727-6767 FAX: 1-408-727-4842*

*Website: [www.klsupply.com](http://www.klsupply.com)*

K&L SUPPLY CO., INC developed this document for its Licensees and customers.

The information contained herein is the property of K&L SUPPLY CO., INC and can not be copied, used, or disclosed to others without prior written approval from K&L SUPPLY CO., INC

Users are cautioned that the material contained herein is subject to change by K&L SUPPLY CO., INC at anytime and without prior notice.

## NOTE TO THE USER

Thank you for purchasing this MOTORCYCLE LIFT.  
Please read these instructions carefully for safe and proper use of the lift, and keep for future reference.

This Manual is for MC615R AIRLIFT

1. READ MANUAL FOR ASSURANCE OF SAFETY IN DESIGN AND CONSTRUCTION OF LIFT.
2. PLEASE MAKE SURE THAT THIS MANUAL IS DELIVERED TO END USERS TO ENSURE PROPER OPERATION OF LIFT.
3. DO NOT USE THE MOTORCYCLE LIFT IN A POTENTIALLY EXPLOSIVE ATMOSPHERE

- NO PART OF THIS MANUAL MAY BE REPRODUCED IN ANY FORM WITHOUT PERMISSION OF K&L SUPPLY CO, INC..
- THIS PRINT IS SUBJECT TO CHANGE WITHOUT NOTICE.

Copyright (C) K&L SUPPLY CO., INC

---

## WARRANTY

The warranty period of the Motorcycle Lift shall be for a period of one year from the date of delivery to sales agent.

Subject to the limitations set forth below,

Contractor warrants that the Motorcycle Lift will be free from defects in material and workmanship and agree to, at part, including repaired or replaced parts, in the which they are (1) due solely to be defective material and/or poor workmanship on the part of contractor and/or its sub-contractors and (2) for which a 30 day notice given to the contractor in writing or by FAX. Please confirm in writing within (30) thirty days after discovery of any defects that will be claimed.

This warranty is subject to the following conditions:

- 1) Motorcycle Lift shall be properly used and operated by the company's operator solely in accordance with the specifications and operating instructions provided by contractor.
- 2) This warranty shall not be constructed to cover any defects due to;
  - Normal wear and tear;
  - Bad operation and maintenance not in accordance with the operating and maintenance manuals to be provided by contractor;
  - Operation under conditions other than those listed in the specification and drawings;
  - Change in design or other modification by company without contractor's consent;
  - Movement or transfer without contractor's consent;
  - Consumable items within normal operation;
  - Any other carelessness not attributable to contractor.

Contact your sales agent for warranty coverage.

***K&L SUPPLY CO., INC***

1040 Richard Ave, Santa Clara, CA, USA, 95050

TELEPHONE: 1-800-727-6767

FAX: 408-727-4842

---

## TABLE OF CONTENTS

---

<b>NOTE TO THE USER .....</b>	<b>2</b>
<b>WARRANTY .....</b>	<b>3</b>
<b>TABLE OF CONTENTS .....</b>	<b>4</b>
<b>CHAPTER 1. SAFEGUARDS</b>	
1-1 Important Notices .....	6
1-2 Qualified Personnel .....	7
1-3 Danger Notices .....	8
1-4 Principle Safety Objective.....	8
1-5 Safety Notices .....	9
1-6 Essential Safety Checks (ESC's) .....	14
1-7 Illumination .....	14
1-8 Level of Sound Pressure .....	15
1-9 Training .....	15
<b>CHAPTER 2. OVERVIEW OF MACHINE</b>	
2-1 Specifications .....	16
2-2 Diagram.....	17
2-3 Picture .....	18
<b>CHAPTER 3. INSTRUCTION</b>	
3-1 INSTRUCTION.....	19
<b>CHAPTER 4. MAINTENANCE</b>	

4-1	General caution during maintenance.....	21
4-2	Check List and periodic maintenance.....	22

**APPENDIX**

1.	SPARE PART .....	23
1-1	Spare Part .....	23
1-2	Spare Part List.....	24
2.	OPTIONAL EQUIPMENT .....	25

## CHAPTER 1. SAFEGUARDS

Please read this chapter carefully for safe and proper use of the motorcycle lift. K&L Supply Co. will not be held responsible for any injuries or accidents that occur due to the motorcycle lift being operated without having understood the contents of this instruction manual. Keep the Instruction Manual close to the motorcycle lift so that anyone can refer to it when necessary. Also, designate a person to take care of the manual.

### ***1-1 Important Notices***

A Motorcycle lift must be considered to be a potential hazard to the health and safety of the motorcycle lift's operator and service personnel. It is important that this motorcycle lift is installed, maintained, and operated according to the instructions set out within this manual. This is a responsibility imposed on the customer by the EU Council Directive 89/655/EEC, concerning the minimum safety and health requirements for the use of work equipment by workers at work.

Any modification, alteration or addition to the motorcycle lift or the fitting of ancillary equipment must comply with the EU Council Directive(s). K&L Supply does not accept any liability whatsoever, which can result in legal action from failure to comply with these regulations, or any consequential loss, claim or counter claim for damage, personal injury, or death arising as a result of any modification, alteration or addition to the motorcycle lift or the fitting of ancillary equipment.

### EU Council Machinery Directive 98/37/EC

The above machinery directive requires all new machinery to carry the CE mark, declaring conformity with all relevant EN standards in respect of safety systems and motorcycle lift construction.

All K&L SUPPLY MACHINERY carries the CE mark and thus conforms to the EU Directives. Any modification to the motorcycle lift can invalidate the original CE certificate; therefore always refer to K&L SUPPLY CO., INC. as reassessment can be required.

This document provides the information required for the intended use of lifting a motorcycle. The documentation is written for technically qualified personnel such as engineers or maintenance specialists who have been specially trained and who have the specialized knowledge required in the field of industrial machinery.

Knowledge of the safety instructions and warnings contained in this document and the appropriate application are prerequisites for safe installation as well as safety in operation and maintenance of the motorcycle lift as described.

Only qualified personnel who have the specialized knowledge that is necessary to correctly interpret the general guidelines relating to the safety instructions and warnings and implement them in each particular case.

For the sake of clarity, not all details of all versions of the product are described in these documents, nor can it cover all conceivable cases regarding installation, operation and maintenance. Should you require further information or face special problems that have not been dealt with sufficient detail in this document, please contact the manufacturer specified on cover page.

We would also point out that the contents of this product documentation should not become a part of or modify any prior or existing agreement, commitment or legal relationship. The purchase agreement contains the complete and exclusive obligations of K&L SUPPLY CO., INC. Any statements contained in this document do not create new warranties or restrict the existing warranty.

## **1-2 Qualified Personnel**

Persons who are not qualified should not be allowed to operate the motorcycle lift. Non-compliance of the warnings contained in this document or appearing on the motorcycle lift can result in severe personal injury or damage to property. Only qualified personnel should be allowed to work on this motorcycle lift.

Qualified persons as referred to in the safety precautions in this document as well as on the motorcycle lift itself are defined as follows:

- Operating personnel who have been trained to work with the motorcycle lift

and are conversant with the contents of these documents are allowed to perform actual operation of lift;

- Service personnel who are trained to repair the motorcycle lift and who are authorized to energize, clear, ground, and tag circuits, equipment and systems in accordance with established safety practices.

### **1-3 *Danger Notices***

The safety precautions in this manual are classified into the following four levels. Please be particularly careful when performing operations that have a high degree of danger.

**DANGER:** Failure to follow this safety precaution can result in great physical danger to the operator, or even death.

**CAUTION:** Failure to follow this safety precaution can result in great physical danger to the operator, or severe damage to the motorcycle lift.

**WARNING:** Failure to follow this safety precaution can result in an injury to the operator, or damage to the motorcycle lift.

**NOTICE:** Failure to follow this safety precaution can result in damage to the motorcycle lift.

### **1-4 *Principle Safety Objective***

- 1) The principle safety objective is to remove the possibility of any hazard or risk to the health or safety of the lift's operator or service personnel.
- 2) Extreme caution must be exercised while servicing or installing the motorcycle lift.
- 3) The only safe policy when operating or inspecting this motorcycle lift is to follow the instructions in this manual. Wherever possible shut off all



electrical power and follow the procedures outlined in this manual.

- 4) Accident prevention should become part of standard working, operating and maintenance procedures, and training should be provided to ensure safety standards are understood. Part of safety training should include the instructions outlined in this section.
- 5) If ancillary equipment is to be fitted ensure this is done in accordance with the relevant standards or EU Directives, and that all requirements for safety are fully met.
- 6) Always ensure suitable qualified personnel carry out servicing and maintenance tasks. The operator should understand the limits of their responsibility, and the training should reinforce the importance of not exceeding them.
- 7) The essential safety checks (ESC's) serve an important function in ensuring the motorcycle lift continues to operate in a safe manner. These checks must be carried out according to the instructions and intervals covered in this manual.
- 8) If there are any questions or doubts regarding any aspect of motorcycle lift safety or operation or maintenance, please contact the company shown on the front of this manual.

## **1-5 Safety Notices**



To protect the operator or service personnel from any injuries or accidents during operating the motorcycle lift, please read this section carefully for safe and proper use of the motorcycle lift.

### **⊙ General Safeguards**



1. Only qualified personnel should be allowed to operate or service this motorcycle lift.
2. Prior to operation routine inspection should be carried out in accordance with the procedures described in the manual.







3. When abnormal conditions not specified in this instruction manual occur during operation, stop operation of the motorcycle lift and contact the manufacturer specified on cover page or distributor.
4. This lift is for motorcycle use only.

⊙ Danger Notices

	<p>Do not stand or sit under the motorcycle lift while raising the motorcycle. This can result in physical danger or death.</p>
	<p>Maintain a safe distance from the lift if there is a possibility of the motorcycle falling down. Failure to do so can result in physical danger or death.</p>

⊙ Caution Notices

	<p>Use the lift after carefully reading the instruction manual and understand the contents of them for safe and proper use of the motorcycle lift.  If a user does not follow the warnings, a serious accident can occur</p>
	<p>When loading a motorcycle onto the lift, keep the motorcycle balanced and centered on lift.  A motorcycle can fall during attachment or detachment of components.</p>

	<p>Only qualified personnel should be allowed to operate or work on this motorcycle lift.</p> <p>Accidents can occur due to wrong operation.</p>
	<p>Do not attempt to keep lift raised by any other means than the built in locking mechanism.</p> <p>The motorcycle can fall; resulting in physical danger or death.</p>
	<p>Do not shake the motorcycle while operating lift.</p> <p>The motorcycle can fall; resulting in physical danger or death.</p>
	<p>Do not raise the lift with only one side of the motorcycle on the lift deck.</p> <p>Motorcycle can fall down or damage can occur to the lift.</p>
	<p>Never modify the safety devices.</p> <p>If safety devices are not working, a serious accident can occur.</p>
	<p>While lowering the lift, be careful not to put your foot under the tabletop.</p> <p>Serious injury can occur.</p>

## ⊙ Warning Notice

**WARNING**

Use the lift after carefully reading the instruction manual and understand the contents of them for safe and proper use of the motorcycle lift.

## &lt; During preparation &gt;

1. This Lift is for motorcycle use only. Do not use for any other purpose.
2. Do not use the lift whenever any of the safety devices are not operating properly.
3. Be cautious and smooth when loading or removing motorcycles from lift.
4. Be careful of footing when the tire, floor, or lift is wet.

## &lt; During lifting and lowering the lift &gt;

5. Always watch the motorcycle while operating the lift to ensure that there are no problems taking place while raising or lowering.
6. If several lifts are installed, observe the location of the switch to be clear of any obstacles.
7. Do not lift a motorcycle exceeding the rated capacity of the lift.
8. Do not lift a motorcycle with people or any other load.
9. Check for oil or foreign material on the lift.
10. Only raise the lift after verifying that the motorcycle is properly positioned.
11. Stop raising the lift after it has reached its maximum height.
12. When raising or lowering the lift, wait 1 or 2 seconds before the next operation is carried out.
13. Do not shake the motorcycle during lifting and lowering of the lift. If the motorcycle is settling to one side, stop the operation of the lift immediately.

**WARNING**

14. If the lift is not lowering in spite of pressing the down pedal, raise the lift and then press the down pedal again.
15. After the lift is completely lowered, the motorcycle can be loaded or removed from the lift.
16. Prohibit unauthorized persons from standing near the lift while it is being raised or lowered.
17. Do not operate the lift with tools or components near the moving parts of the lift. Damage can occur to the lift and motorcycle.
18. When lowering lift, make sure nothing will interfere with its descent.

## &lt; During motorcycle repair &gt;

19. Check if the safety lock device is working properly before operation.
20. Prohibit unauthorized persons from accessing the lift.
21. When the lift is not in use, or will not be in use for a long period, lower the lift completely.

## &lt; Other &gt;

22. Do not change or modify the lift without permission. If the lift is modified or changed, the lift can not operate properly, or a serious accident can occur.
23. If you find a problem with the lift during use or inspection, stop operation and request maintenance from the sales agency. Do not use until the lift is repaired.
24. Please note that this lift is not designed to be waterproof. Do not use the lift in a hot environment, motorcycle-washing or outdoor use.
25. Use the lift after reading the instruction manual carefully and understand the contents of them for safe and proper use.

## 1-6 Essential Safety Checks (ESC's)

The essential safety checks are the most important part of the operator's responsibility. The purpose of the ESC's is to ensure the safety features of the motorcycle lift are functioning properly, and thus the motorcycle lift is in a safe condition for use.

In addition to the operator it is recommended that a responsible person carry out regular additional ESC's and that a record is maintained in accordance with the EU machinery Regulations.

If any of the ESC's result in a "Fail" condition do not operate the motorcycle lift, immediately notify the responsible person within the company and contact the manufacturer as soon as possible.

### ESSENTIAL SAFETY CHECKS (ESC'S)

#### GROUP 1 GENERAL - Visual Inspection

ESC	Description	O.K.	Fail
1A	Safety Lock Mechanism		
2B	Lift Deflection or Distortion		

## 1-7 Illumination

This machine does not provide local lighting since it is designed for indoor use only. The factory in accordance with the appropriate code of practice and factory regulations must fulfill sufficient illumination of the working area. Minimum 300 lx is required. Flicker, dazzling, shadows and stroboscopic effects must be avoided to prevent risk.

### **1-8 Level of Sound Pressure**

The equivalent continuous A-weighted sound pressure levels of the motorcycle lift do not exceed 85dB (A).

	<p>The factory must provide operator(s) with the appropriate measures including but not limited to an ear protection and a warning sign(s) If the sound pressure WARNING of 85dB (A) is exceeded.</p>
---	---

### **1-9 Training**

Contact the manufacturer specified on cover page for information on training courses to aid you in becoming familiar with this motorcycle lift.

## CHAPTER 2. OVERVIEW OF MACHINE

### 2-1 Specifications

<b>MC615R Air Lift</b>	
Capacity	1,000 lbs (450kg)
Width	24.0 " (610 mm)
Length	84.0" (2,130 mm)
Maximum Height	35.0" (900 mm)
Minimum Height	7.25" (185 mm)
Platform Thickness	0.128" (3.25 mm)
Weight	330 Lbs (148.5 kg)
Max Air Pressure	100 PSI
Lifting Time	Approx: 20-30 Sec
Lowering Time	Approx: 30 Sec



**2-2 Diagram**

**MC615R Air Lift**

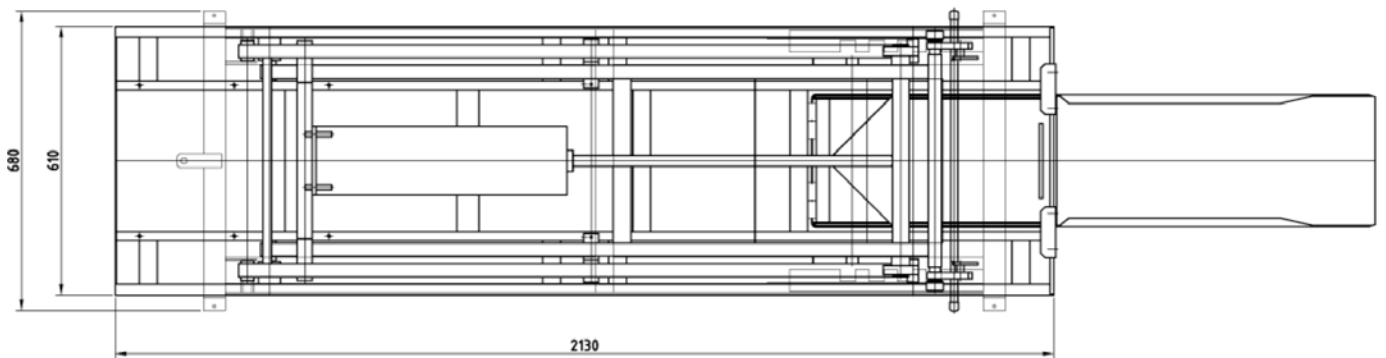
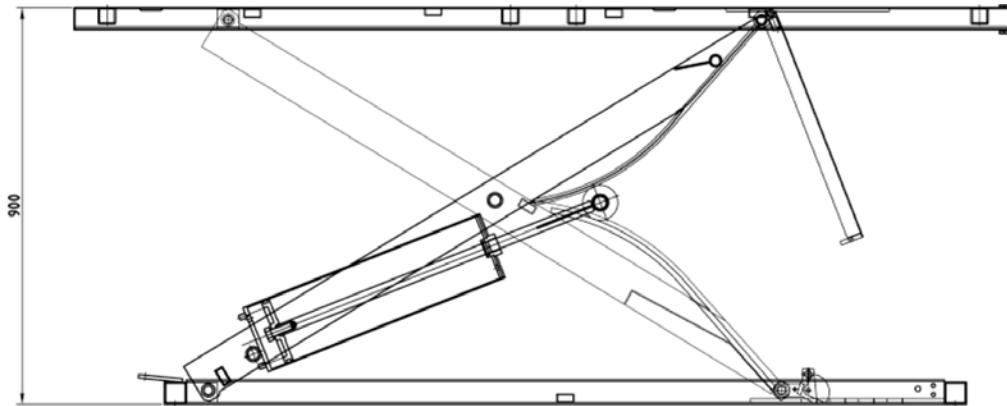

2-3 Picture

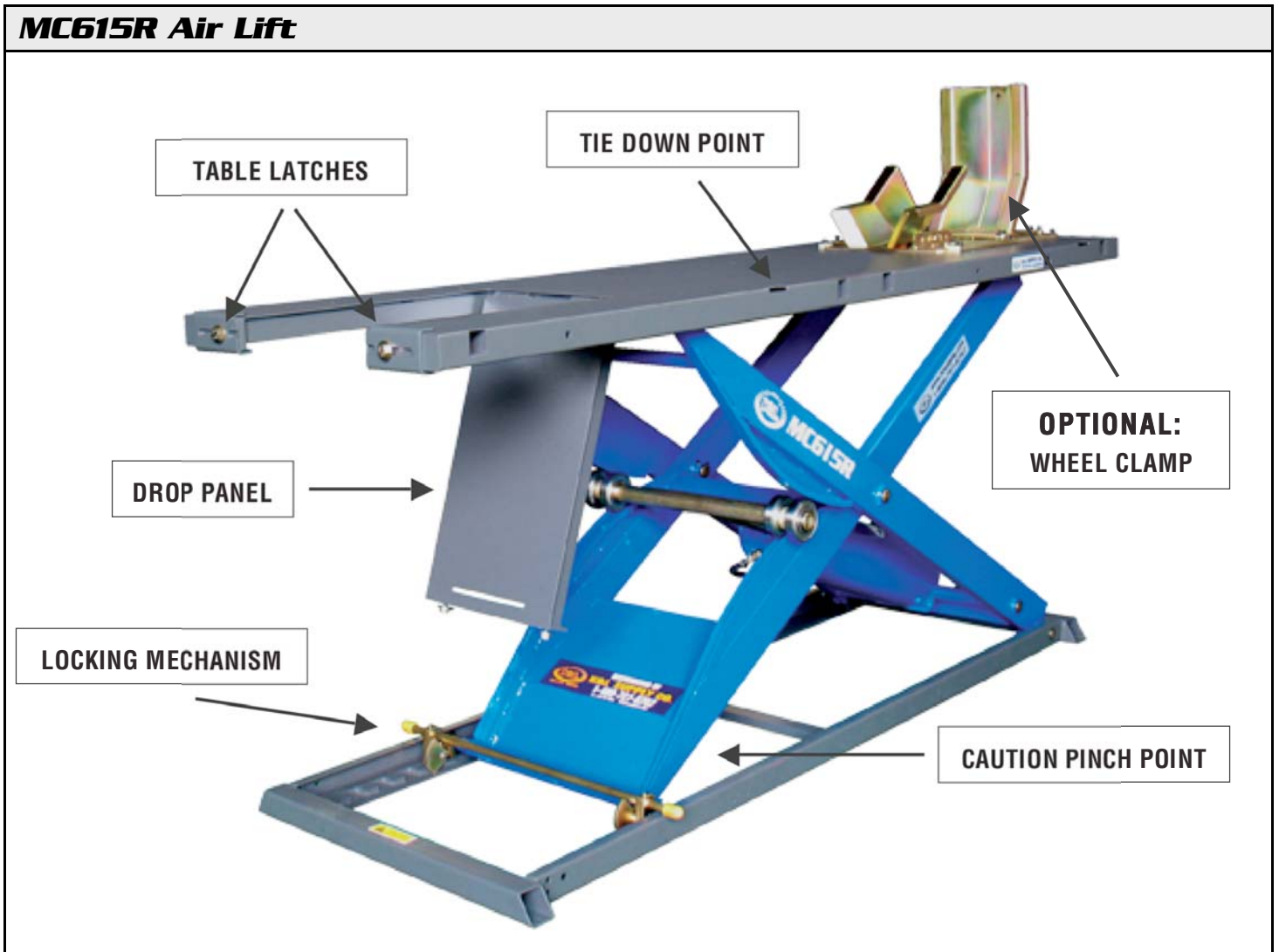

Dual Foot Control Pedal

## CHAPTER 3. INSTRUCTION

### 3-1 INSTRUCTION

**Caution:** This product is intended for use by professionals in the performance of mechanical repairs on powersports vehicles and is to be considered dangerous if not maintained or if used improperly. The lift should be placed on a flat concrete surface to prevent unit from tipping or rocking during use.

**STEP 1.** Check product and bill of materials to make certain all required parts are accounted for and in good condition.

**STEP 2.** Raise Lift to working height to verify front and rear drop-out operation. Slide latches off of retention bolts (See photo A) while holding the drop-out, then check to make sure the panel travels downward freely. Make sure to hold the drop-out portion and not let it fall freely.



< Photo A >

**Caution:** Never operate lift while drop down panels are in the down position. Return them to the level position until the safety lock is set. (See photo B)



< Photo B >

- STEP 3.** Attach vise rails in the appropriate holes on the deck of the lift. (See photo C) Slide vise into rails and make sure there is space to allow a smooth sliding motion. Tighten rails to the deck and recheck sliding of clamp. Tighten pinch bolts to hold vise to the deck of the lift.



< Photo C >

- STEP 4.** Attach ramp to rear of the lift while in the down position.
- STEP 5.** Always use tie-downs to secure vehicle to the lift while operating.
- STEP 6.** If applicable, attach side extensions as needed. No hardware or tools needed for application

**Caution:** Do not leave ramp attached to lift while in operation or in up position. Do not leave ramps for the extensions attached while in operation or in the up position.

**Notes:** Be aware of all marked pinch points. Lubricate all points at least 3 times a year or more depending on frequency of use. Make sure all air lines are securely fastened; be aware of all pinch points. Lubricate all moving parts at least 3 times a year. Depending on frequency of use you can need to do this more often.

## CHAPTER 4. MAINTENANCE

### ***4-1 General caution during maintenance***

- 1) Two or more persons should perform maintenance.
- 2) Maintenance should be carried out after putting a signboard of "NO ENTRANCE" at work area.
- 3) Do not disassemble the system before you are familiar with the disassembling sequence.
- 4) Record the place or parts where maintenance is needed.
- 5) Keep disassembled parts stored where they can be easily accessed.
- 6) Be sure to fasten bolts and nuts position correctly during assembly.
- 7) During maintenance, verify locks are in "engaged" position.
- 8) Inspect air lines and fittings at least once a month.
- 9) Check weekly for loose nuts and bolts. Retighten if needed.

**4-2 Check List and periodic maintenance**

Maintenance Interval Chart							
The following chart should be considered strictly as a guide to general maintenance intervals. Depending on operating conditions, the intervals of maintenance should be changed.							
Maintenance Interval		Initial		Thereafter Every		Part#	
		10 hours	25 hours	50 hours	100 hours	200 hours	
		1 month	3 months	6 months	12 months	24 months	
Item							
Bolts	Inspect			X	X		603
Pivot Pin	Inspect		X		X		13, 14, 20
Pivot Pin Circlip	Inspect, Replace			X	X		608, 609
Lubrication Points	Lubricate	X	X	X	X		
Drop Panels	Inspect			X	X		2
Sliding Lock	Inspect			X	X		12
Rollers	Inspect	X		X	X		16, 17
Cylinder	Inspect	X		X	X		7
Cylinder Seal	Visually Inspect	X		X	X		
Bearings	Inspect	X		X	X		612
Safety Lock Guide	Inspect	X	X	X	X		18
Locking Bar	Inspect	X	X	X	X		6
Pedal	Inspect	X	X	X	X		22
Air Valve	Inspect	X	X	X	X		23

# APPENDIX

## APPENDIX

### 1. SPARE PART

#### 1-1. Spare Part

#### **K&L MC615R Air Lift**

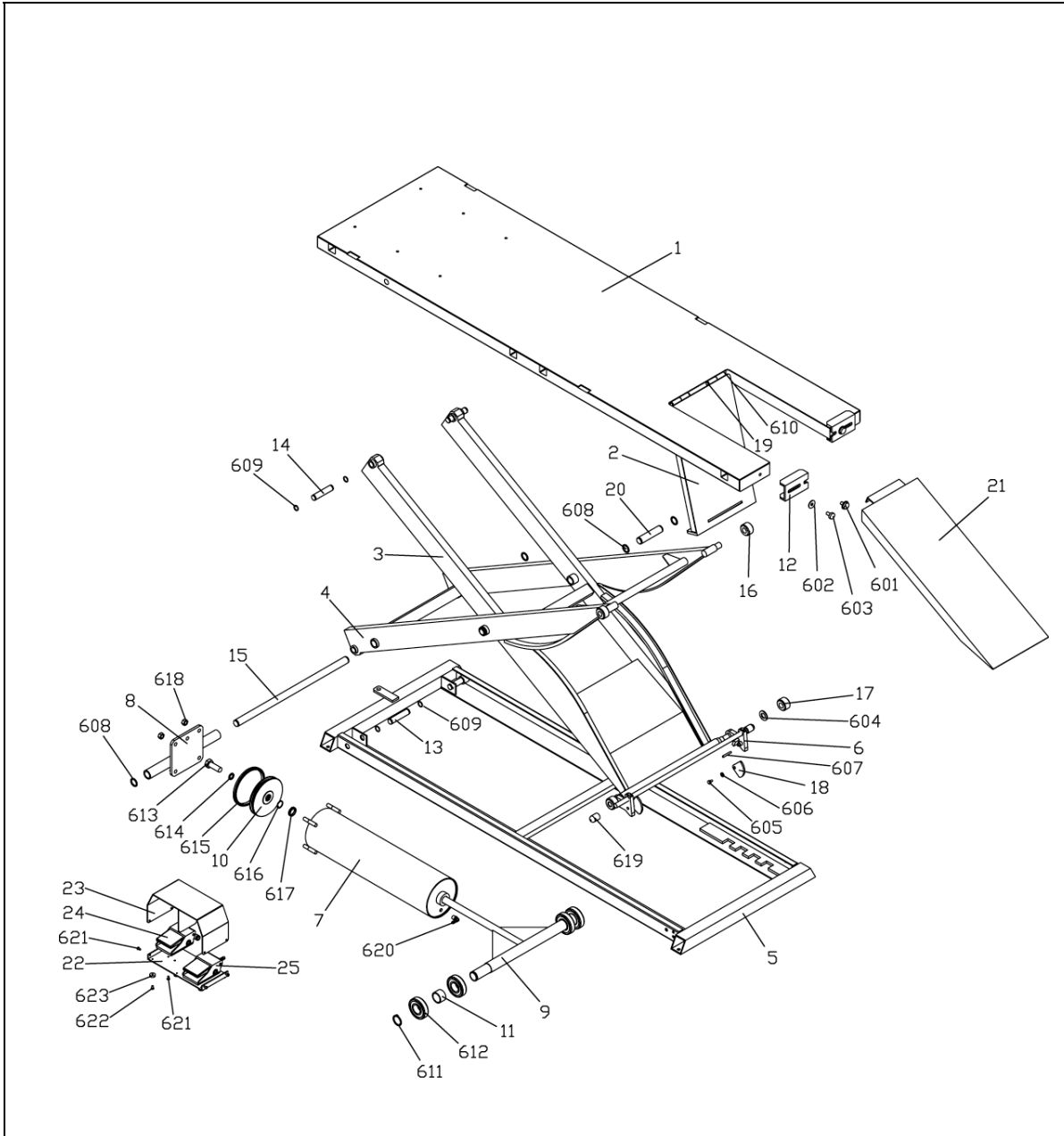

# APPENDIX

## 1-2. Spare Part List

**K&L SUPPLY CO., INC.**

PART NO. 35-6292, 35-6293, 35-6294



NO.	DESCRIPTION	WEIGHT/ SIZE	Q'TY/EA	NO.	DESCRIPTION	WEIGHT/ SIZE	Q'TY/EA
1	UPPER PLATE		1	601	SLIDE LOCK BOLT	M10 x 25	2
2	REAR DROP PLATE		1	602	SLIDE LOCK FLAT WASHER	Ø10xØ30x3t	2
3	MAIN SUPPORT - A		1	603	SLIDE LOCK FLANGE BOLT	M10 x 25	2
4	MAIN SUPPORT - B		1	604	FLAT WASHER	Ø16 x 3t	2
5	BASE		1	605	ROUND HEAD ALLEN BOLT	M6 x 12	2
6	SAFETY LOCK ASSEMBLY		1	606	FLAT WASHER	Ø6	2
7	CYLINDER		1	607	SPRING PIN	Ø6 x 40	2
8	CYLINDER BRACKET		1	608	CIRCLIP	S25	6
9	CYLINDER ROD		1	609	CIRCLIP	S20	8
10	PISTON		1	610	CIRCLIP	S12	4
11	SPACER		2	611	CIRCLIP	S35	2
12	SLIDE LOCK (LEFT/RIGHT)		2	612	BALL BEARING	#6307	4
13	PIN - A	Ø20 x 90	2	613	HEX. BOLT (CM)	M18 x 50	1
14	PIN - B	Ø20 x 81	2	614	SPRING WASHER (CM)	Ø18	1
15	CYLINDER PIVOT SHAFT	Ø25 x 554	1	615	U - PACKING	SKY 136	1



## APPENDIX

16	ROLLER - A	Ø38 x 25	2	616	O - RING	S25	1
17	ROLLER - B	Ø38 x 25	2	617	U - PACKING	SKY 25	1
18	SAFETY LOCK GUIDE		2	618	NYLON NUT	M12	4
19	DROP PLATE PIN	Ø12 x 88	2	619	YELLOW RUBBER CAP	Ø16 x 3t	2
20	MAIN SHAFT	Ø25 x 120	2	620	ELBOW HOSE NIPPLE	Ø9-PT1/4	1
21	RAMP		1	621	ROUND HEAD SCREW	M5 x 12	8
22	FOOT PEDAL BRACKET FOR CE		1	622	ROUND HEAD SCREW	M4 x 10	6
23	FOOT PEDAL COVER FOR CE		1	623	RUBBER FOOT	Ø4	6
24	UP - PEDAL ASSEMBLY FOR CE		1				
25	DOWN - PEDAL ASSEMBLY FOR CE		1				

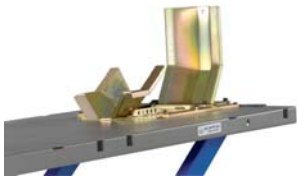
## 2. OPTIONAL EQUIPMENT

	<p><b>35-4040 MC10R Deluxe Wheel Clamp</b>  MC10R Deluxe Wheel Clamp. Self-locking clamp allows one person to load motorcycle on lifts. Comes with std. width rocker. (Fits 120 to 160 series tires)</p> <p><b>35-4041</b> Optional <b>Narrow Rocker</b> for 90 to 110 tires</p>
	<p><b>35-9926 Crank Style Wheel Vice</b>  Can be used on front or rear tires</p>

## APPENDIX

 A blue hydraulic lift with four grey side panels and two grey ramps attached to its sides, increasing its width.	<p><b>35-6295 ATV Side Panels</b></p> <p>Complete Side Panel Set. Increases width from 24.0" to 48". Includes side panels (qt 4) and ramps (qt 2)</p>
 A blue hydraulic lift (Fat Jack) and a blue shop dolly (MC460) with a yellow deck.	<p><b>37-8660 MC455 Fat Jack</b></p> <p><b>35-9872 MC460 Shop Dolly</b></p>
 A set of four retractable wheels (two yellow and two black) and a metal frame component for the lift.	<p><b>35-0321 Retractable Wheel Set</b></p> <p>Set of wheels for MC series lifts. This accessory allows the lift to be easily moved.</p>
 A yellow lift extension kit consisting of a long metal bar with mounting brackets at each end.	<p><b>35-0318 Lift Extension Kit</b></p> <p>Adds 30" to your lift; and features easy bolt-on installation. Fits all flat deck style lifts.</p>
 A small black nosewheel with a metal stem and a T-shaped handle.	<p><b>35-6770 Nosewheel</b></p> <p>Use with 35-0321 retractable wheels for easy moving of lift.</p>