

KRAUS ISOLATED RISERS

FOR 1" AND 1-1/8" BAR

REPLACEMENT PART LIST:

ITEM	QTY	PART NO.	PART
1	2	UN-ISO-001/021	ISO RISER MID SECTION (1"/1-1/8")
2	1	UN-ISO-002/022	ISO RISER TOP CLAMP (1"/1-1/8")
3	2	UN-RI-35/45/75/95	ISO RISER LEGS 3.5", 5.5", 7.5", 9.5"
4	8	1173462	18-8 STAINLESS STEEL SOCKET HEAD SCREW, 1/4-20 X 1
5	2	110120384	MEDIUM-STRENGTH GRADE 5 STEEL HEX HEAD SCREW, ZINC-PLATED, 1/2-13 X 2-1/2, PARTIALLY THREADED
6	4	UN-RI-014	RISER BUSHING WASHER - TOURING
7	4 EA.	UN-RI-004	POLYURETHANE RISER BUSHING
8	2 EA.	UN-RI-004	METAL SLEEVE FOR POLY RISER BUSHING
A or B	2	13824	MEDIUM-STRENGTH GRADE 5 STEEL HEX HEAD SCREW, ZINC-PLATED, 1/2-13 X 3, FULLY THREADED
C	2	1113821	MEDIUM-STRENGTH GRADE 5 STEEL HEX HEAD SCREW, ZINC-PLATED, 1/2-13 X 2, FULLY THREADED

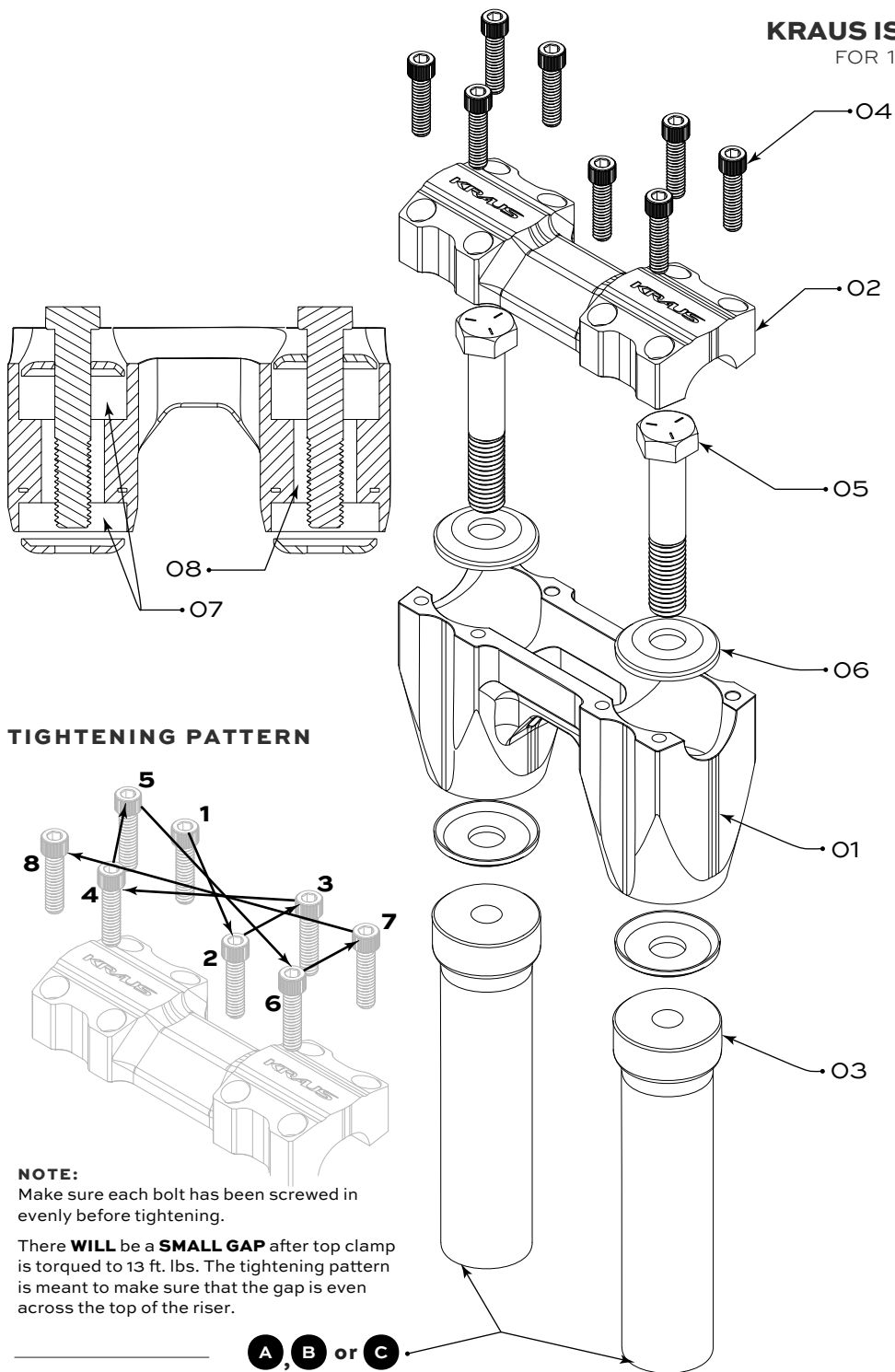

MOUNTING BUSHING SETS INCLUDED: (DEPENDS ON FITMENT)

FITMENT:
ALL TOURING MODELS AND
2018 & UP SOFTAILS

FITMENT:
ALL DYNA, FXR AND
2017 & BELOW SOFTAILS

FITMENT:
ALL MODELS RUNNING A KRAUS
DYNAMOTO INVERTED FRONT END

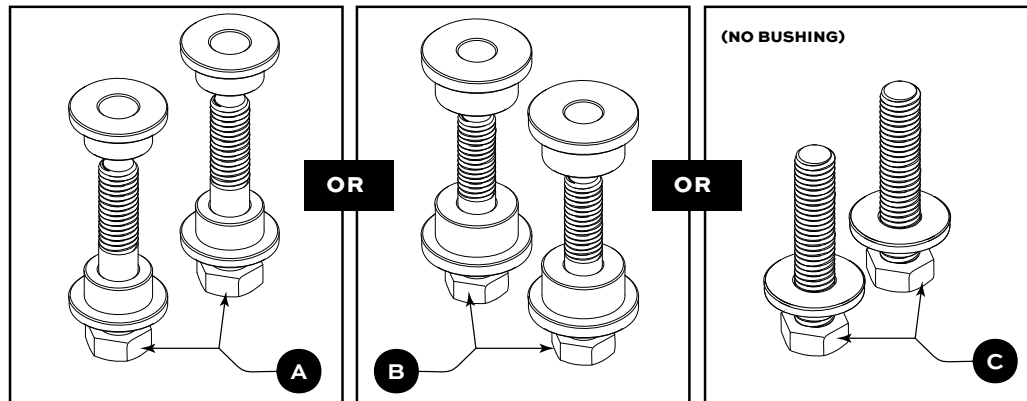

TORQUE SPECS:

- A** (SOLID MOUNT RISER BUSHING - TOURING/18 & UP SF) APPLY BLUE LOC-TITE 243 TO 1/2-13 X 2-1/2, GRADE 5 ZINC PLATED HEX HEAD SCREW, FULLY THREADED — **55 FT. LBS.**
- B** (DYNA/FXR/17-BELOW SF SOLID RISER BUSHING) APPLY BLUE LOC-TITE 243 TO MEDIUM-STRENGTH GRADE 5 STEEL HEX HEAD SCREW ZINC-PLATED, 1/2-13 X 3, FULLY THREADED — **55 FT. LBS.**
- C** (KRAUS DYNAMOTO SOLID RISER BOLT & WASHER (NO BUSHING)) MEDIUM-STRENGTH GRADE 5 STEEL HEX HEAD SCREW ZINC-PLATED, 1/2-13 X 2 LONG, FULLY THREADED — **55 FT. LBS.**

#04 18-8 STAINLESS STEEL SOCKET HEAD SCREW, 1/4-20 X 1 — **13 FT. LBS.**

#05 MEDIUM-STRENGTH GRADE 5 STEEL HEX HEAD SCREW, ZINC-PLATED, 1/2-13 X 2-1/2, PARTIALLY THREADED — **55 FT. LBS.**