



INSTALLATION INSTRUCTIONS

LOWDOWN | SOFTAIL®

MINIMUM REQUIRED TOOLS:



FLAT HEAD SCREWDRIVER



1/2", 9/16", 14mm, 7/8" or 22mm WRENCHES



5/16", 1/2", 9/16" SOCKETS AND RATCHET



SNAP RING PLIERS



3/16", 1/4", 5/16" ALLEN WRENCH



TORQUE WRENCH



SYSTEM SHOWN IN CHROME

INCLUDED HARDWARE:

- (2) O2 ADAPTER
- (2) O2 PLUG SOCKET
- (2) NUT PLATE 3/8-16
- (6) BOLT HEX 3/8-16 x 0.625
- (2) MUFFLER CLAMP 1.75inch
- (4) HEAT SHIELD CLAMP 1.75inch
- (1) CABLE TIE
- (1) THREADLOCKER

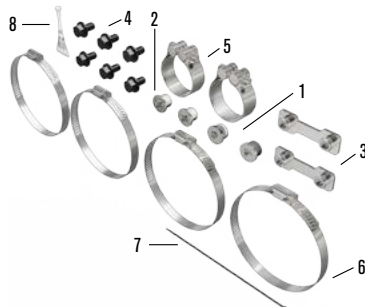

IMPORTANT INFORMATION:

- Register your new product at www.magnaflow.com/motorcycle/register.
- When installing new MagnaFlow exhaust systems, be sure your hands are clean and free of oil, lotion or similar products. After installation is completed and before starting the motorcycle, thoroughly clear the new exhaust system with a clean, soft cloth and cleaning solvent that leaves no residue. Debris, residue or fingerprints left on the system may cause damage to the finish. Damage or discoloration to finish is not covered by warranty.
- MagnaFlow advises replacing worn or damaged gaskets. Replacement gaskets must be of OEM cone style.
- Make sure there are no exhaust leaks at the junctions and connecting points of the exhaust pipes and/or mufflers, or at the cylinder.
- Leaks due to improper installation may cause the engine to overheat. This may cause discoloration.

MagnaFlow makes every effort to design exhaust systems which improve the riding experience. However, due to restraints on some motorcycle models, tolerances, ground and or cornering clearance may not improve and in some cases may be reduced. Be sure to carefully follow all installation instructions.

Magnaflow Exhaust Systems meet criteria established by the EPA. Emission tests have been performed according to EPA standards, which demonstrate that these exhaust systems will not cause similar vehicles to fail to meet applicable emission standards over the useful life of the of the vehicle.

DISCLAIMER: Some part numbers not available in California. The California Air Resources Board (CARB) does not permit the use of aftermarket emission-related part(s) that alter the performance of OEM emission-related devices unless CARB has issued an Executive Order. Check your local laws and manufacturer's information.

YEAR 1996-2015

CHROME PART # 7211701 • 7212301

BLACK PART # 7211804 • 7212404



- | | | |
|----------------------|---------------------|---------------------|
| 1. FRONT HEAD PIPE | 4. REAR HEAD SHIELD | 7. MOUNTING BRACKET |
| 2. REAR HEAD PIPE | 5. MUFFLER | |
| 3. FRONT HEAD SHIELD | 6. TWIN CLAMP | |



NOTICE

Maximize your motorcycle performance and efficiency by complementing your new MagnaFlow exhaust system with a fuel tuner management system. Arlen Ness fuel tuners take the guess work out of fuel management and help your bike run at optimal levels. For a total performance package see the full line of Arlen Ness air cleaners and air cleaner kits. Specially designed, Arlen Ness air cleaners let your motor breathe for maximum performance gains.

View the complete collection of Arlen Ness fuel tuners and air cleaner kits at your local dealer or visit www.ArlenNess.com

Platforms, model names and descriptions including but not limited to Dyna®, Softail®, Sportster®, Touring®, Fat Boy®, Road Glide®, Heritage® and Harley® are registered trademarks of The Harley-Davidson Motor Company®, Milwaukee, WI, U.S.A.

WARRANTY:

MagnaFlow motorcycle exhaust products, including Arlen Ness by MagnaFlow exhaust systems, are warranted against defects in material and/or assembly workmanship only for a period of 90 days from invoice date. This warranty is void if the product is not installed properly on the vehicle for which it is designed. This warranty does not apply to any product which has been installed on any commercial or racing vehicle or which has been improperly installed, modified, altered or subjected to misuse or damage from accidents; including excessive heat. Also, cost of labor and any additional parts or components required to complete installation of a replacement product are not covered by this warranty; including coatings, paints and/or finishes, flaws or rust. MagnaFlow including Arlen Ness by MagnaFlow exhaust systems are designed to fit and operate on original OEM motors and chassis with no modifications of any type on the motorcycle.

Proof of purchase from an authorized retailer must accompany any warranty claim. The original product that is deemed to be under warranty may only be returned and/or exchanged for a product of the same part number. No other warranty, expressed or implied (including merchantability), applies to the products, nor is any person including the manufacturer authorized to assume any other warranty. Dealers and distributors are not authorized to make warranty judgments or claims regarding MagnaFlow products. The manufacturer does not assume any responsibility for any consequential damages occasioned by the product, or inconvenience or interruption in any operation, service or shipping. All approved warranty returns must be accompanied by a return authorization number. Parts returned to MagnaFlow without a return authorization and accompanying documentation may be refused. No parts will be accepted with freight due.

This warranty gives you specific legal rights. You may also have other rights which may vary from state to state. Some states do not allow the exclusion or limitation of incidental or consequential damages, so the above limitation or exclusion may not apply to you. The warranties set forth herein are exclusive and, unless otherwise required by applicable law, no other warranties are made by MagnaFlow or are authorized to be made with respect to the product.

STOCK EXHAUST REMOVAL INSTRUCTIONS

PLEASE NOTE:

Several MagnaFlow motorcycle exhaust systems are designed to be used with O2 and non-O2 sensor applications. If your motorcycle does not come equipped with O2 sensors, simply skip any steps referring to them.

1. Locate both the front and rear O2 sensors and unplug them from the factory wiring harness. Remove any cable ties holding them in place. Note the wiring location and routing.
2. Carefully remove the two mounting nuts located at each flange holding the head pipes to the cylinders. It may be necessary to loosen or remove the heat shields for better access. Make sure to retain the nuts as they will be used during the installation.
3. Locate and remove the exhaust bracket mounted to the frame and exhaust mounting bar.
4. On each muffler, remove the bolts attaching them to the exhaust mounting bar and remove the stock exhaust pipes, and mufflers. Make sure to prevent any damage to the O2 sensors since they will be reused.
5. Remove the O2 sensor using a 7/8 inch or 22 mm wrench. To insure continued performance from your stock O2 sensors, keep any fingerprints, debris or chemicals from the tip.
6. Remove the foot controls along with the brake rod by removing the T30 screw or e-clip from the rear eyelet.
7. Locate and remove the two exhaust mounting studs from the frame (Figure 1).



Fig 1

8. From the stock exhaust system, remove the circlips and mounting flanges to reuse with the new system. Be sure to replace any reused hardware that is worn or damaged before installing your MagnaFlow motorcycle exhaust system.



LOWDOWN INSTALLATION INSTRUCTIONS

PLEASE NOTE:

Several MagnaFlow motorcycle exhaust systems are designed to be used with O2 and non-O2 sensor applications. If your motorcycle does not come equipped with O2 sensors, simply skip any steps referring to them. It will be necessary to install the supplied O2 sensor plugs during the installation process.

1. Install the supplied, MagnaFlow exhaust mounting bracket using the factory hardware (Figure 2).



Fig 2

2. Re-install the foot controls and brake rod.

3. Install the factory mounting flanges and circlips, removed for the factory system, on the new head pipes. (Figure 3)



Fig 3

5. Install the mufflers to the head pipes using the supplied 1.75 inch muffler clamps. Do not tighten at this time to allow for adjustment.

6. Carefully install the factory O2 sensors into the new head pipes.

7. Attach the heat shield clamps the heat shields by inserting the end of the clamp through the retaining bracket (Figure 4)



Fig 4

8. Insert the head pipes into the heat shields and attach the clamps (Figure 5). Do not tighten at this time to allow for adjustment.



Fig 5

9. Install the head pipes to the exhaust ports using the factory exhaust port nuts. Do not tighten the nuts at this time to allow for adjustment.

10. Insert the supplied nut plates into the muffler mounting braces and attach the mufflers to the new mounting bracket using the 3/8-16x0.625 bolts (Figure 6). Do not tighten at this time to allow for adjustment.



Fig 6

11. With the screw head facing the motorcycle, insert the larger opening of the Twin Clamp onto the mufflers and over heat shields. Make sure that the mufflers are fully inserted in the Twin Clamp and the Twin Clamp overlaps the heat shields approximately 3/8 inch. Do not tighten at this time to allow for adjustment. (Figure 7)

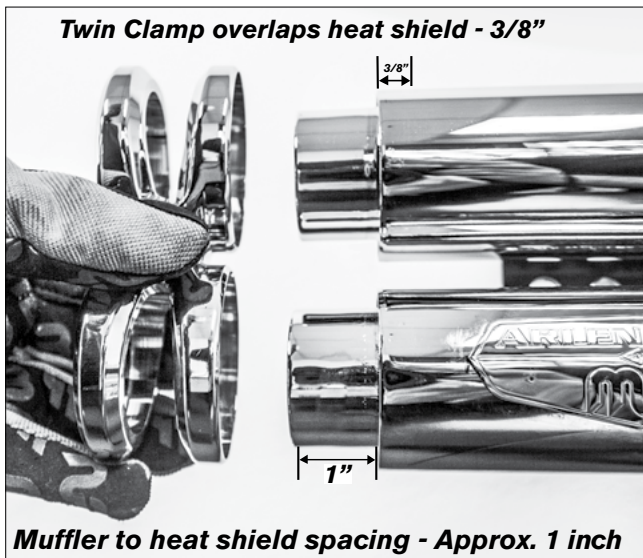

Fig 7

12. Making sure that the front and rear head pipes are parallel, tighten the exhaust port nuts to factory specifications.

13. Fully tighten the mounting bracket bolts.

14. Adjust and fully tighten the heat shield clamps.

15. Fully tighten the Twin Clamp screw. Figure (8)



Fig 8

16. Re-route and plug in the O2 wiring harnesses. Install the supplied cable tie on the front O2 wire harness at its original location.

17. Before starting the motorcycle, make sure to check that all of the exhaust components including O2 wiring have been properly installed and have proper clearance to avoid damage. Make sure that all hardware has been tightened to factory specifications.



IMPORTANT NOTICE

California Customers Emissions Notice

In California, the sale and installation of motorcycle aftermarket exhaust parts that may have the potential to impact emissions are regulated by the California Air Resources Board (CARB). The sale, installation and use of emissions related aftermarket exhaust parts on motorcycles is prohibited unless the exhaust part is either an OEM "replacement part" as defined by the state California, or is specifically authorized for use by an Executive Order issued by CARB.

(1) Replacement Parts

Replacement Parts are aftermarket parts that are functionally identical to the stock OEM part they are intended to replace, and therefore do not adversely impact emissions when installed and in use. Replacement Parts are permitted for sale, installation and use on motorcycles used on or off the public highways in California. For motorcycles, these parts fall in to two categories:

* No emission control - If the motorcycle's stock exhaust system does not contain any emission control components, then an aftermarket exhaust part is a Replacement Part and no EO is required.

* Upstream emission control device. If the motorcycle's stock exhaust system contains a catalytic converter, then an aftermarket exhaust part positioned downstream from the catalytic converter (i.e. cat-back) is a Replacement Part as long as it does not remove or replace any emission control equipment originally attached to the stock exhaust system.

(2) Executive Order Parts

All exhaust parts that incorporate or impact any emission control device require a CARB issued Executive Order allowing the parts to be advertised, sold, offered for sale and installed in California, pursuant to specific application.

For more information please see visit www.arb.ca.gov/msprog/aftermkt/motorcycle1/motorcycle1.htm

Application	Part Number	Product Name	Platform	Finish	Year Fitment
49 State Federal Application	7200103	Redline Slip-ons	Touring	Chrome	1995-2015
California Application	7200103	Redline Slip-ons	Touring	Chrome	1995-2015
49 State Federal Application	7200301	MegaCone Slip-Ons	Touring	Chrome	1995-2015
California Application	7200301	MegaCone Slip-Ons	Touring	Chrome	1995-2015
49 State Federal Application	7210903	Redline Tru-Duals	Touring	Chrome	2009-2015
	7211404	Redline Tru-Duals	Touring	Black	2009-2015
	7211003	Redline Tru-Duals	Touring	Chrome	1995-2008
	7211504	Redline Tru-Duals	Touring	Black	1995-2008
California Application	7211003	Redline Tru-Duals	Touring	Chrome	2004 & 2007
	7211504	Redline Tru-Duals	Touring	Black	2004 & 2007
49 State Federal Application	7211103	Redline Tru-X	Touring	Chrome	2009-2015
	7211604	Redline Tru-X	Touring	Black	2009-2015
49 State Federal Application	7211401	MegaCone Tru-Duals	Touring	Chrome	2009-2015
	7212302	MegaCone Tru-Duals	Touring	Black	2009-2015
	7211501	MegaCone Tru-Duals	Touring	Chrome	1995-2008
	7212402	MegaCone Tru-Duals	Touring	Black	1995-2008
California Application	7211501	MegaCone Tru-Duals	Touring	Chrome	2004 & 2007
	7212402	MegaCone Tru-Duals	Touring	Black	2004 & 2007
49 State Federal Application	7211601	Megacone Tru-X	Touring	Chrome	2009-2015
	7212502	Megacone Tru-X	Touring	Black	2009-2015

Application	Part Number	Product Name	Platform	Finish	Year Fitment
49 State Federal Application	7211203	Ness-Comp	Touring	Chrome	2009-2015
	7211704	Ness-Comp	Touring	Black	2009-2015
	7211303	Ness-Comp	Softail	Chrome	1996-2015
	7211904	Ness-Comp	Softail	Black	1996-2015
	7211403	Ness-Comp	Dyna	Chrome	2008-2015
	7212104	Ness-Comp	Dyna	Black	2008-2015
California Application	7210203	Ness-Comp	Softail	Chrome	2007
	7210304	Ness-Comp	Softail	Black	2007
	7210803	Ness-Comp	Dyna*	Chrome	2008-2015
	7211304	Ness-Comp	Dyna*	Black	2008-2015
49 State Federal Application	7211701	Lowdown	Softail	Chrome	1996-2015
	7211804	Lowdown	Softail	Black	1996-2015
	7212101	Lowdown	Sportster	Chrome	2004-2015
	7212204	Lowdown	Sportster	Black	2004-2015
	7211901	Lowdown	Dyna*	Chrome	2008-2015
	7212004	Lowdown	Dyna*	Black	2008-2015
California Application	7211701	Lowdown	Softail	Chrome	2007
	7211804	Lowdown	Softail	Black	2007
	7212101	Lowdown	Sportster	Chrome	2006-2013
	7212204	Lowdown	Sportster	Black	2006-2013
	7211901	Lowdown	Dyna*	Chrome	2008-2015
	7212004	Lowdown	Dyna*	Black	2008-2015
49 State Federal Application	7211801	F-Bomb	Softail	Chrome	1996-2015
	7212602	F-Bomb	Softail	Black	1996-2015
	7212201	F-Bomb	Sportster	Chrome	2004-2015
	7212802	F-Bomb	Sportster	Black	2004-2015
	7212001	F-Bomb	Dyna*	Chrome	2008-2015
	7212702	F-Bomb	Dyna*	Black	2008-2015
California Application	7211801	F-Bomb	Softail	Chrome	2007
	7212602	F-Bomb	Softail	Black	2007
	7212201	F-Bomb	Sportster	Chrome	2006-2013
	7212802	F-Bomb	Sportster	Black	2006-2013
	7212001	F-Bomb	Dyna*	Chrome	2008-2015
	7212702	F-Bomb	Dyna*	Black	2008-2015
49 State Federal Application	7200401	Twin Wall Back Cut	Softail	Chrome	2007-2015
	7200801	Twin Wall Back Cut	Softail	Chrome	1995-2015
	7200801	Twin Wall Back Cut	Sportster	Chrome	2004-2015
	7200801	Twin Wall Back Cut	Dyna*	Chrome	1991-2015
California Application	7200401	Twin Wall Back Cut	Softail	Chrome	2007
	7200801	Twin Wall Back Cut	Softail	Chrome	2007
	7200801	Twin Wall Back Cut	Sportster	Chrome	2006-2013
	7200801	Twin Wall Back Cut	Dyna*	Chrome	91-94, 06-15

49 State Federal Applications- May not be advertised, offered for sale, sold or installed in California. *Dyna Fat Bob®, Low Rider® and Switchback® fitment products may not be sold in California.