



INSTALLATION & USER'S GUIDE

TorqDrive® Clutch Pack
For Harley Davidson
Revolution Max Engines

Doc ID: 191-2815010A
Revision: 090622

TABLE OF CONTENTS

OVERVIEW	2
INSTALLATION TIPS	3
TOOLS NEEDED.....	3
DISASSEMBLE THE CLUTCH	4
INSTALL THE CLUTCH PACK	9
Notes for clutch pack installation:	9
REINSTALL CLUCTH COVER.....	11
BREAK-IN.....	13
TROUBLESHOOTING.....	13
Clutch Drag	13
Clutch Slip	13
MAINTENANCE.....	14
Disk inspection examples	14
NEED ADDITIONAL HELP?.....	16

OVERVIEW

This guide shows you how to replace your OE (Original Equipment) or “stock” clutch parts with your new Rekluse TorqDrive® clutch parts. The following parts are replaced:

- OE Drive Plates
- OE Friction Disks

Visit www.rekluse.com/support for a full parts fiche illustration and part numbers.

INSTALLATION TIPS

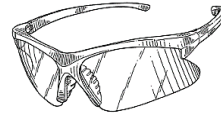

- Read the separate included Safety Information document before operating the vehicle with the product installed.
- Read this entire document before performing any steps.
- If you install this product for a customer or another person, instruct them to read the **Safety Information** document and the **Installation and User Guide** before operating the bike with the product.
- Protect eyes and skin – wear safety glasses and work gloves.
- Use the torque values listed in the instructions. Otherwise, use the torque specifications found in your OE service manual.
- For optimal clutch performance Rekluse recommends using fresh, clean oil that **meets JASO-MA** oil rating requirements. Rekluse offers Factory Formulated Oil™ developed specifically for Rekluse products. Rekluse Factory Formulated Oil is a perfect complement to any OEM or aftermarket wet clutch. Visit www.rekluse.com to learn more.
- Inspect your OE cable for fraying and replace if needed.

TOOLS NEEDED

- Fluid Catch Container
- Dental Picks
- Metric Wrench Set
- Metric Socket Set (8mm, 13mm, 15mm)
- Torque Wrench
- Torx Bit Set (T25, T27, T40)
- Needle nose pliers
- Crescent wrench

DISASSEMBLE THE CLUTCH

1. Soak the Rekluse friction disks in new oil for at least 5 minutes. Coat the friction disks on both sides.

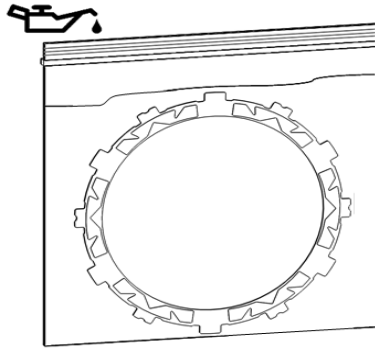

2. Prepare the bike for the installation. Lean the bike to the left on its Jiffy stand to eliminate draining the oil. Be sure the bike is stable.
 - If you prefer, you can secure the bike on a lift and drain the oil.
3. Remove the main fuse to disconnect the power.

NOTE: *For the Sportster S skip to step 12*

4. Remove the skid plate and right side engine guard
5. Remove the lower fairings. The lights do not allow the fairings to be completely removed. Tie them up to keep them out of the way.

6. Remove the center stand spring bracket and the pivot screw from each side

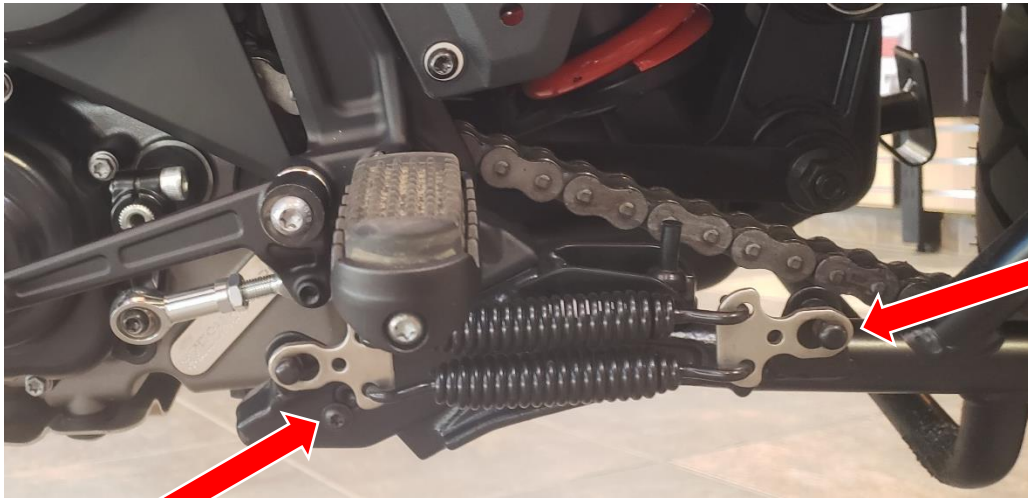

Spring
Bracket

Pivot Screw

7. Remove the pivot pins then the center stand.
8. Remove the two mounting bracket bolts on the right hand side to gain access to the muffler pipe clamp

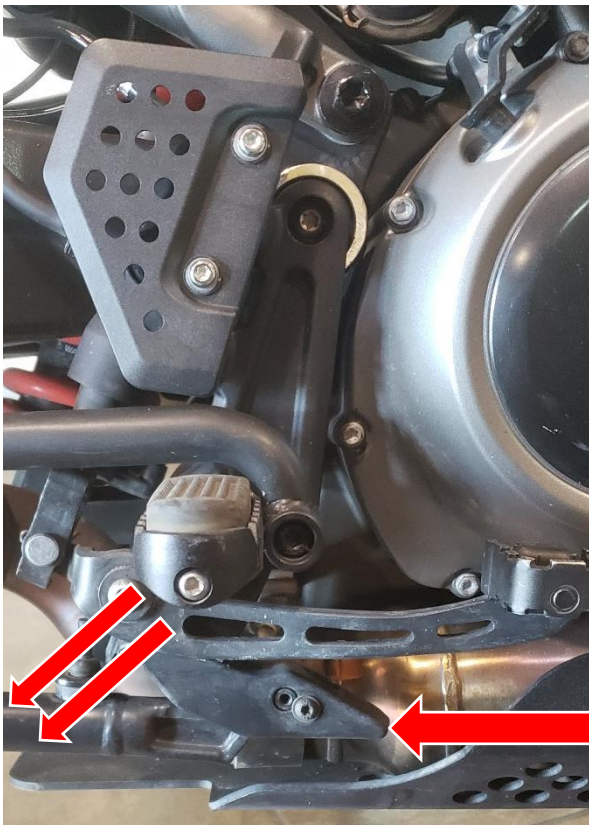

Remove to access
muffler pipe clamp

9. Loosen the muffler pipe clamp and mounting screw to remove the muffler.

10. Remove the radiator mounting screws and position it away from the engine in order to gain access to the exhaust header.

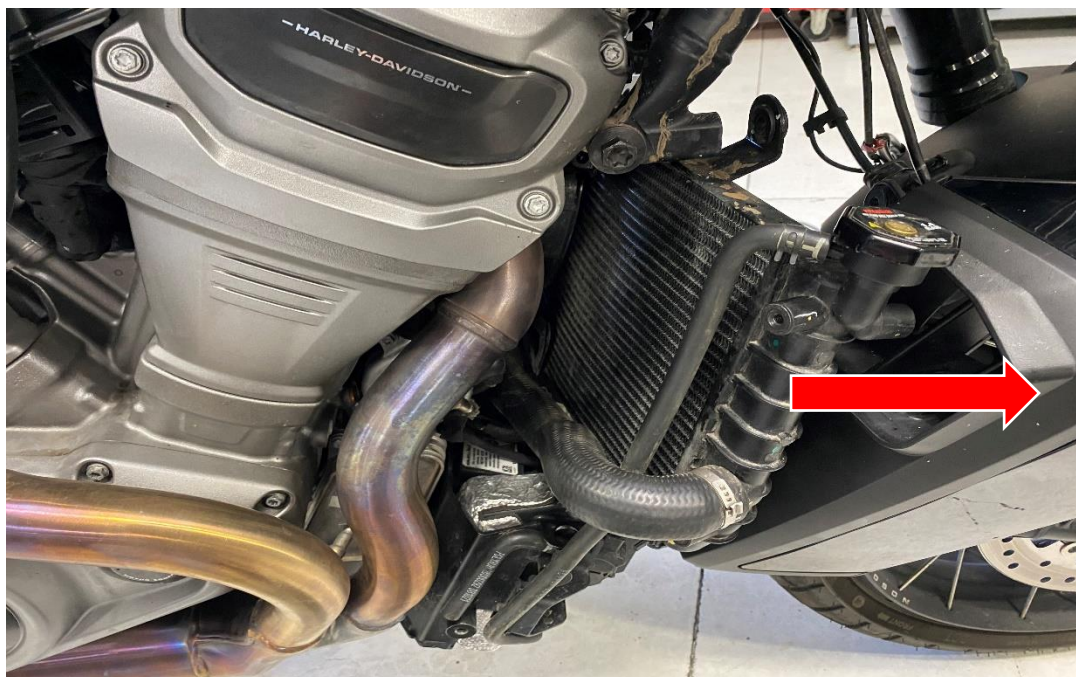

NOTE: Coolant does not need to be drained. Be careful you do not disconnect any hoses while repositioning.

11. Disconnect the front and rear oxygen sensors below the front exhaust header. Removal now will aid in the exhaust removal and prevent damage to the wiring.

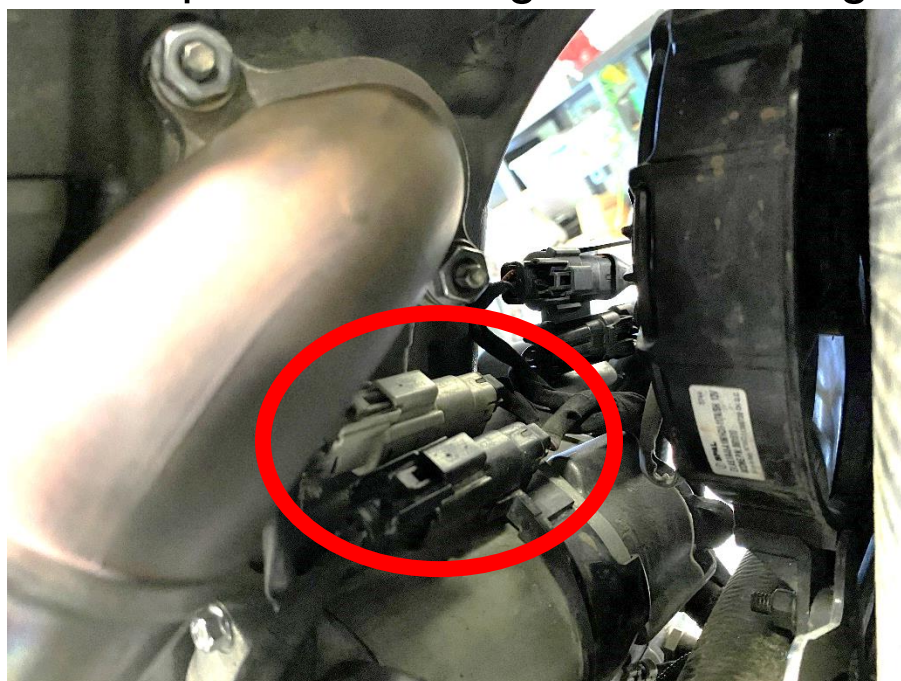

12. Remove the two screws on the front header and the loosen the pipe clamp on the rear header.

13. Remove the exhaust pipe.

14. Loosen the clutch cable and disconnect it from the actuator arm on the primary cover. Take note of the original position for installation.



15. Remove the clutch cover bolts, then remove the cover. Set the cover and cover gasket aside. They will be reused.

16. Remove the two screws holding oil baffle and remove the oil baffle. Pay attention to where each screw came from.

17. Use a socket to remove the 3 pressure plate bolts, then remove the spring ring and pressure plate springs. The bolts and spring ring will be reused.

NOTE: Remove the pressure plate bolts in small increments. Removing the bolts completely can bend and damage the spring ring

18. Remove the pressure plate, then remove the OE clutch pack. The pressure plate, judder seat, and judder spring will be reused.

NOTE: The judder spring and seat can remain in the clutch basket.

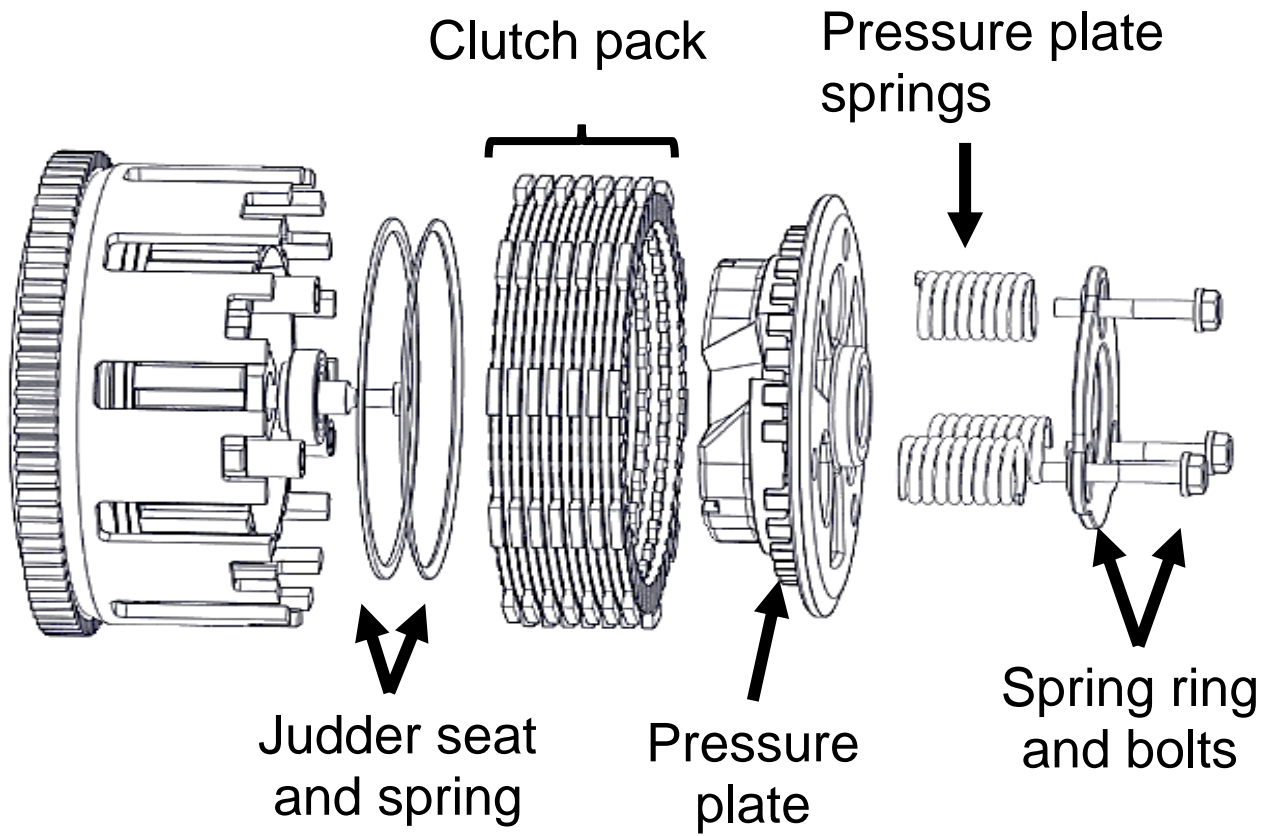

INSTALL THE CLUTCH PACK

Notes for clutch pack installation:

- *Some friction disks are marked with a small colored dot. This mark is used for processing and can be ignored.*
- *Some OE baskets have “half slots” at the top of the basket tangs. Rekluse products require the entire clutch pack be installed into the MAIN (deeper) basket slots.*

Use main (deeper)
basket slots

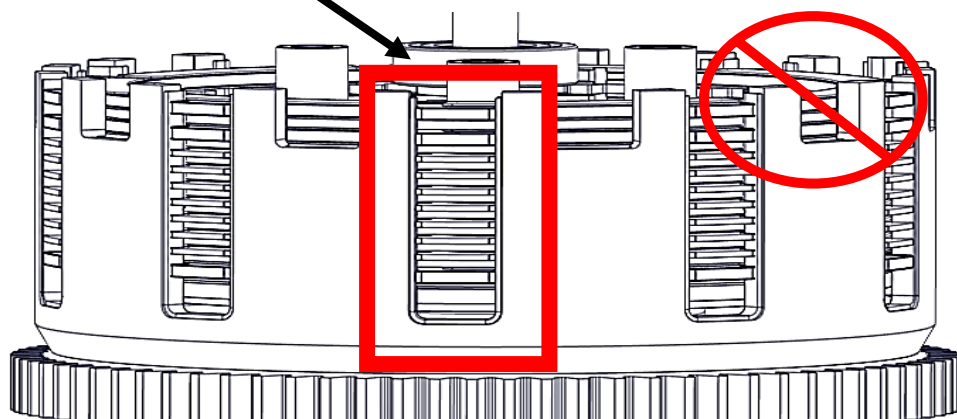

1. Inspect the clutch basket for spring damper play or notching. Do not install sleeves or use product with a notched basket. Notched basket tang faces or worn spring dampers can cause the sleeves to break.

⚠ WARNING

Failure to inspect the basket and replace if necessary could result in death, serious injury, and/or property damage.

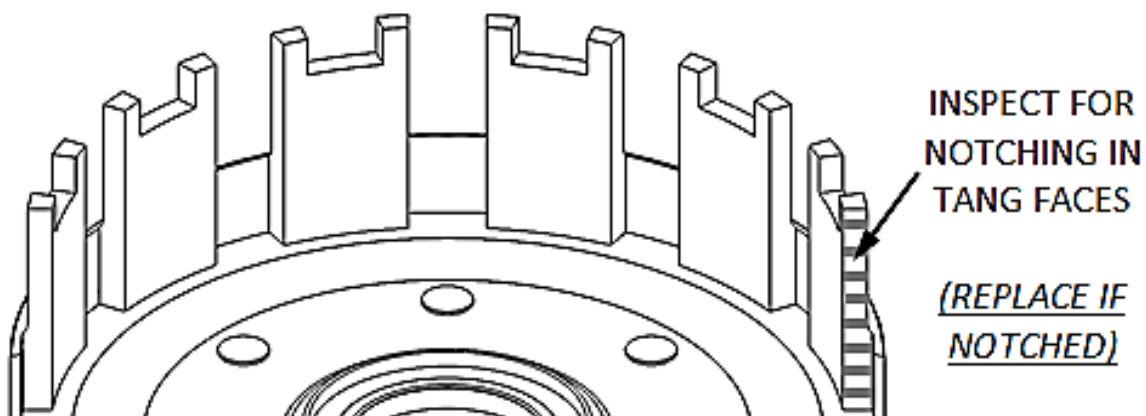

2. Install all the Rekluse basket sleeves into the basket slots. Make sure the bottom of the sleeve is facing down, and the sleeve tabs sit against the inside of the basket.

NOTE: When seated in the basket, the sleeves will sit flush with the top of the basket. This is normal.

Sleeve tabs
sit
inside

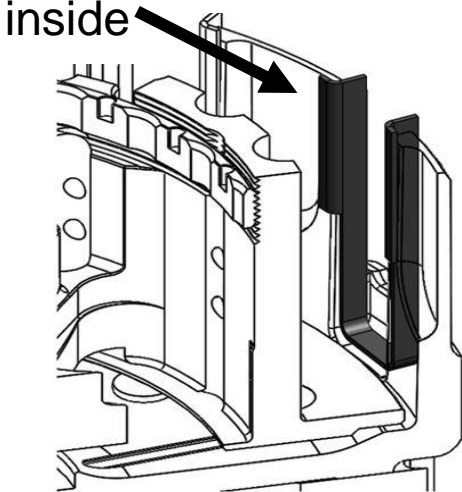

Install all the basket sleeves

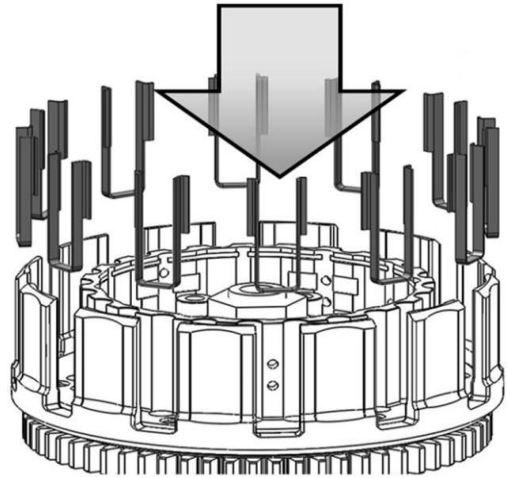

3. Double-check that the OE judder seat and spring are installed in the bottom of the basket.
4. Install the clutch pack. Follow the **setup sheet** at the back of the manual for the clutch plate order and stack height.
5. Set the pressure plate upside down on a workbench. Install the last **thick** friction disk - .118" (3 mm) on top of the pressure plate.
6. Install the **thick** steel drive plate - .060" (1.5 mm) on top of the thick friction. Make sure the drive plate's teeth index to the pressure plate.

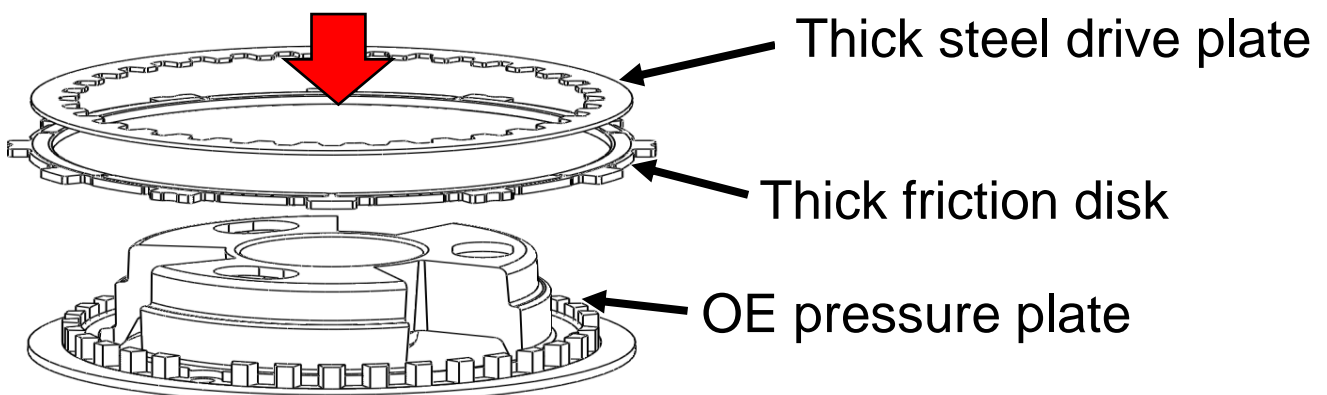

7. Turn the pressure plate assembly over and install it on top of the clutch pack. *Make sure all of the friction disk tabs are aligned in the correct basket slot. They all should be in the basket sleeve slot.*

NOTE: *Pay close attention that the friction and drive plate did not come unindexed during install. There should be no gaps between the clutch pack and the pressure plate.*

8. Install the new Rekluse springs, then reinstall the OE spring ring and OE bolts.
9. Torque pressure plate bolts in small increments to 71-106 in-lb (8-12 N-m) as per OE specifications.

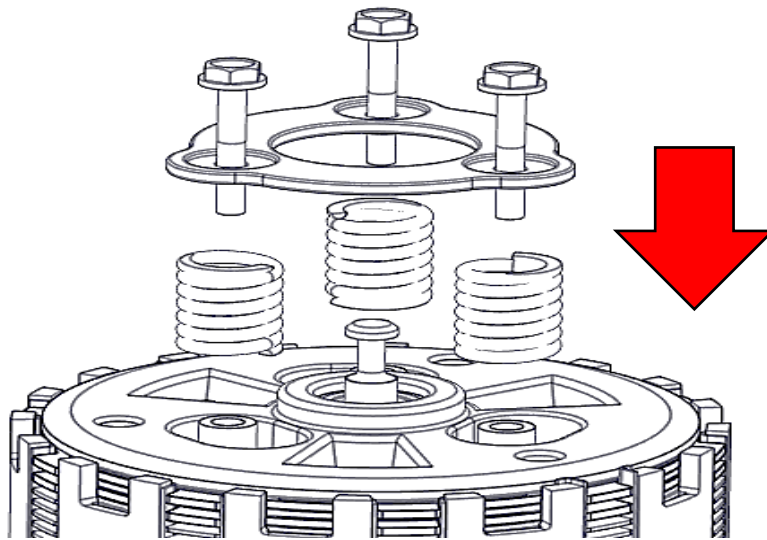

REINSTALL CLUTCH COVER

1. Reinstall the clutch oil baffle. Torque to **80-97in-lbs (9-11 N-m)**
2. Reinstall the clutch cover gasket onto the clutch cover. *Replace the gasket if it shows signs of damage or wear to prevent leaks.*
3. Pull the actuator arm toward the front of the cover so that it is parallel with the side of the cover.
4. Push the cover into place the and check that the actuator arm is engaged. Verify that it is in the same position as it was during disassembly.
5. Reinstall the clutch cover bolts.

6. Lightly tighten the cover bolts in a star pattern.
7. Torque all the cover bolts in small increments in a star pattern to **94-115 in-lb (10.6-13 N-m)** as per OE specifications.
8. Reattach the clutch cable to the actuator arm.
9. Reinstall the exhaust pipe. Torque the header nuts to **15-16 ft-lbs (20-22 N-m)** and the pipe clamp to **71-89 in-lbs (8-10 N-m)**
10. Connect the oxygen sensors that were removed



11. Reposition the radiator and install mounting screws. Torque to **71-89 in-lbs (8-10 N-m)**
12. Install the muffler
13. Reinstall the center stand mounting bracket and center stand. Torque the mounting bracket screws to **25-28 ft-lbs (34.5-38.5N-m)**. Torque the pivot screws to **40-53in-lbs (4.5-6 N-m)**
14. Install the fairings, engine guard, and skid plate.
15. Reconnect the Main Fuse.
16. Check the clutch lever for free play. The clutch lever should move smoothly when it is pulled toward the handlebar and return quickly when it is released.

NOTE: Stock free play is the amount of lever movement from the perch to clutch lever engagement. Clutch lever free

play should measure .04-0.08" (1-2 mm) or about two full turns from finger tight.

BREAK-IN

- The clutch will break in within 100-200 miles of normal riding. Until break-in is complete, you may experience more clutch drag than normal.
- It is recommended to do an oil change after the first 1,000 miles to drain any excess clutch debris that occurred from break-in.

TROUBLESHOOTING

Clutch Drag:

If drag occurs only while the bike is cold, oil is the most likely cause. Be sure to warm up the bike before riding and/or racing. Use of lighter weight oil can help to minimize cold drag.

Clutch Slip:

If clutch slip occurs:

- Inspect the clutch for signs of wear or heat.
- Check that your clutch lever is properly adjusted

MAINTENANCE

To keep your clutch performing at its best, perform regular maintenance on your bike and clutch. Clutch longevity and performance is greatly increased with oil quality and other bike factors that reduce engine heat.

- Inspect all of your clutch parts at regular maintenance intervals for signs wear or excessive heat and replace components as necessary. Clutch wear is dependent on the riders use.
- Measuring the clutch pack can help determine if the components need replacing. Refer to the **Setup Sheet** for the clutch pack service limits.
- Inspect and replace basket sleeves if they appear to be notched from friction disks.
- Replace friction disks if they are glazed and/or burnt.
- Keep up with regular oil changes as per the bike manufacturer's recommendations. Clutch performance and longevity depend on oil quality.
- For optimal clutch performance Rekluse recommends using fresh, clean oil that **meets JASO-MA** oil rating requirements.

Disk inspection examples

When inspecting the clutch pack, the following pictures can be used as a reference. **These are best viewed in color by viewing this install document at www.rekluse.com/support.**

Drive Plates – If the clutch pack is getting high amounts of heat, purple, blue, or black color can be seen on the drive plate teeth. See pictures below. Not all drive plates look the same and may look different than pictured.

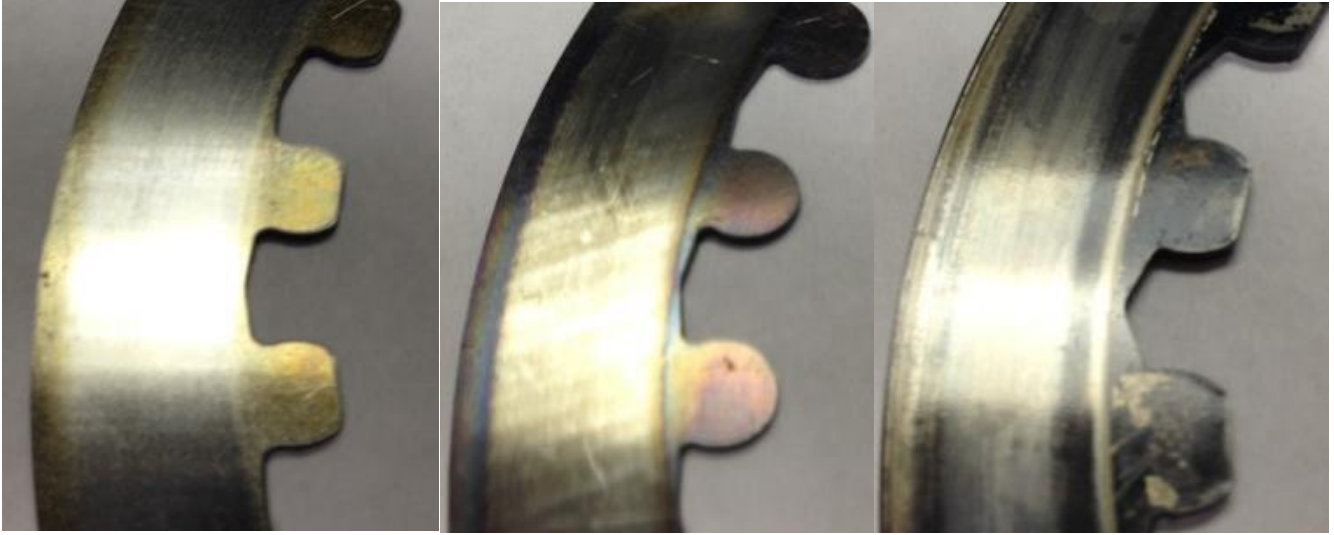

Normal Heat

High Heat
(Blue)

Excessive Heat
(Black)

Friction Disks – Due to the dark color of the friction material, the friction disks will appear almost black as soon as they are put in oil. During inspection, look for glazing of the friction material. Glazing will appear shiny and feel like glass, even after oil is cleaned from the friction disk. Not all friction disks look the same and may look different than pictured.



Normal
Friction



Glazed
Friction

NEED ADDITIONAL HELP?

Website

www.rekluse.com/support

Frequently asked questions

www.rekluse.com/faq

Support Videos

www.rekluse.com/support/videos

Phone

(208) 426-0659

Technical Support

Contact Technical Support for questions related to product installation, tuning, and performance.

Hours:

Monday thru Friday: 8:00 a.m. - 5:00 p.m.

Mountain Time zone

Email: tech@rekluse.com

Customer Service

Contact Customer Service for additional product information, orders, and returns.

Hours:

Monday thru Friday: 8:00 a.m. - 5:00 p.m.

Mountain Time zone

Email: customerservice@rekluse.com

