



INSTALLATION & USER'S GUIDE

TorqDrive[®] Clutch Pack
For Indian Thunder Stroke (2014-Current)

TABLE OF CONTENTS

OVERVIEW	2
INSTALLATION TIPS	3
TOOLS NEEDED.....	3
INCLUDED PARTS	4
DISASSEMBLE THE CLUTCH	5
CLUTCH PACK INSTALLATION.....	7
Notes for installation.....	7
Install the clutch pack.....	8
Install pressure plate.....	12
MAINTENANCE.....	13
Clutch wear	13
INSPECT THE CLUTCH PACK	14
NEED ADDITIONAL HELP?.....	17

OVERVIEW

This kit replaces the OE (Original Equipment) clutch pack with a Rekluse TorqDrive[®] clutch pack. The following parts are replaced:

- All OE steel drive plates will be replaced with Rekluse steel drive plates.
- All OE friction disks will be replaced with Rekluse TorqDrive[®] disks.
- The OE pressure plate springs are replaced with Rekluse springs.

INSTALLATION TIPS



- Read the safety information sheet included with your kit.
- Protect eyes and skin – wear safety glasses and thin disposable work gloves.
- Read this entire document before performing any steps.
- For optimal clutch performance Rekluse recommends using fresh, clean oil that **meets JASO-MA** oil rating requirements. Rekluse offers Factory Formulated Oil™ developed specifically for Rekluse products. Rekluse Factory Formulated Oil is a perfect complement to any OEM or aftermarket wet clutch. Visit www.rekluse.com to learn more.

TOOLS NEEDED

- 5 mm allen wrench
- 6 mm allen wrench
- 8 mm allen wrench
- 10 mm socket
- 13 mm wrench
- Torque wrench
- Fluid catch container

INCLUDED PARTS

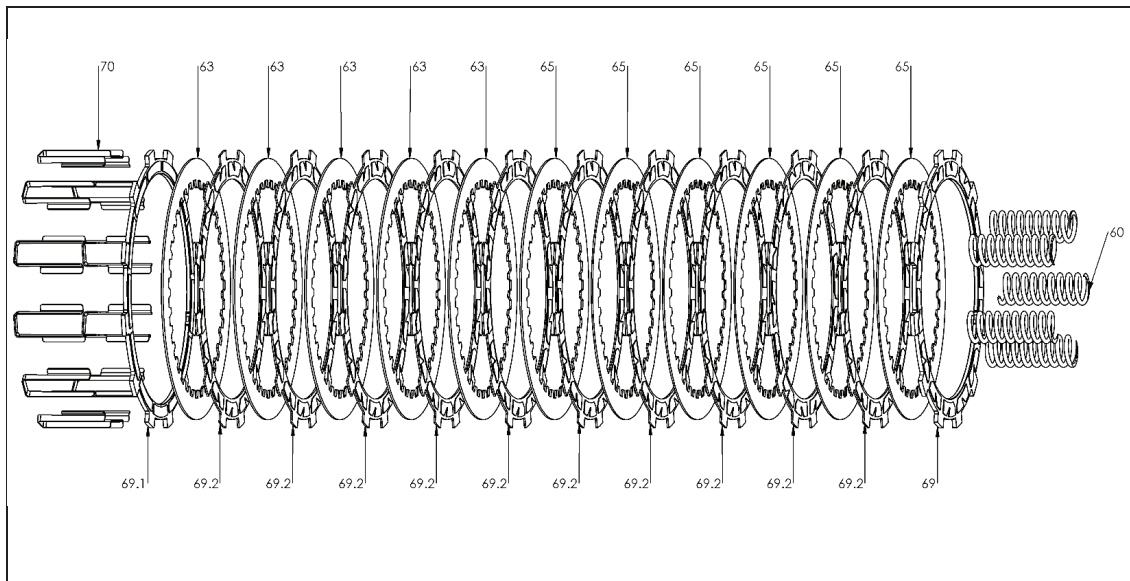

Item	Description	Qty.
60	Rekluse pressure plate springs	5
63	Steel drive plates – .040” (1.0 mm)	5
65	Steel drive plates – .048” (1.2 mm)	6
69	Judder friction disk- .134” (3.4 mm)	1
69.1	Thick friction disk - .134” (3.4 mm)	1
69.2	TorqDrive® friction disks	10
70	Basket sleeves	12

Visit www.rekluse.com/support for a full parts fiche illustration and part numbers.

DISASSEMBLE THE CLUTCH

1. Stand the bike up on a suitable bike stand or lift.

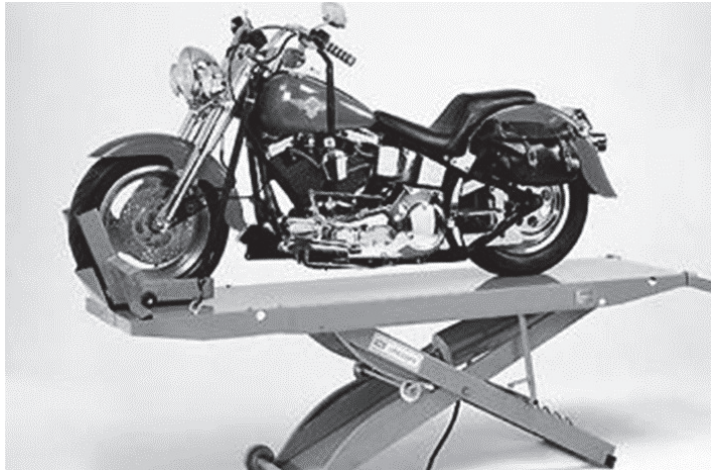

2. Using a pick remove the snap ring retaining the shift cable.
3. Using a 5 mm allen wrench remove the shift linkage and clutch actuator arm.
4. Using a 10 mm socket remove the clutch cable support bracket

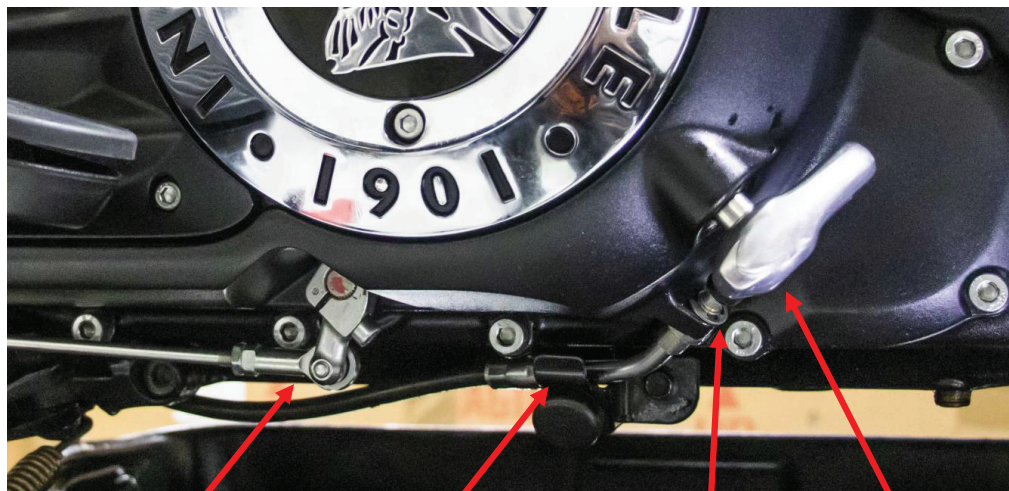

Shift
Linkage

Cable
Support

Snap Ring

Clutch
Arm

5. Using a 8mm allen wrench remove the floorboard assembly.

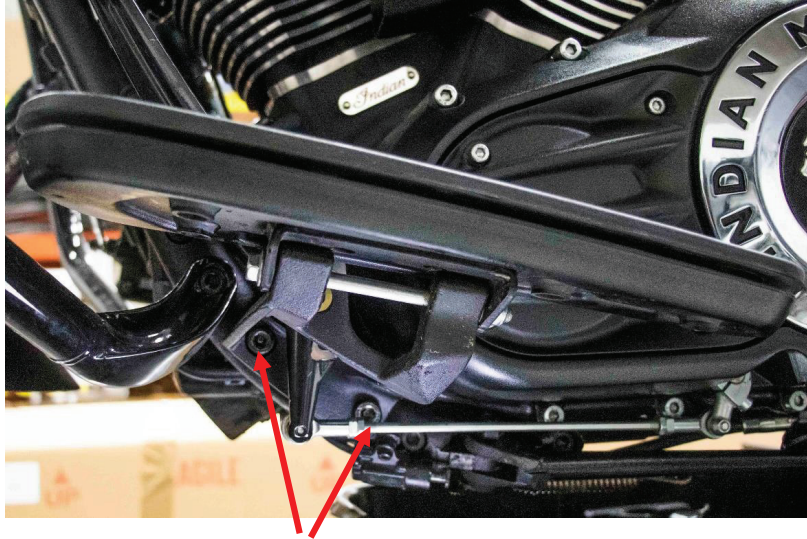

Floorboard Bolts

6. Using a 6 mm allen wrench remove both oil drain plugs draining the oil into a suitable container.
7. Using a 6 mm allen wrench remove the primary cover bolts and the primary cover.
8. Verify the shim has not come off the shift shaft. If the shim is missing check the rear of the primary cover.



9. Use a 10 mm socket and pick set to remove the following OE parts:

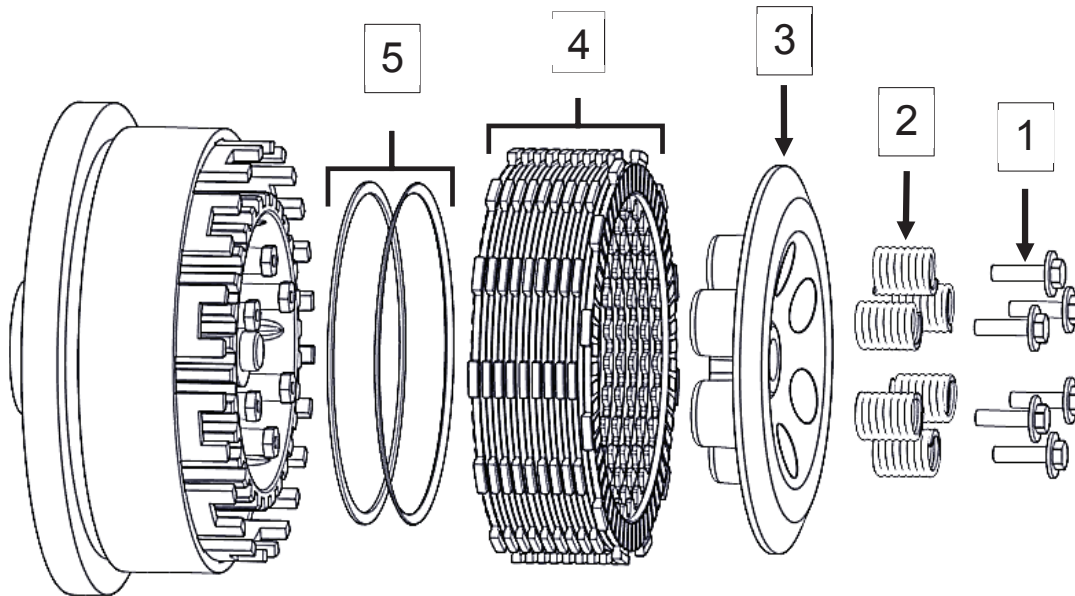

1	Pressure plate bolts
2	Pressure plate springs
3	Pressure plate assembly
4	Clutch pack
5	Judder seat and spring

CLUTCH PACK INSTALLATION

Notes for installation

- *Some friction disks are marked with a small colored dot. This mark is used for processing and can be ignored.*

- *Some OE basket have “half slots” at the top of the basket tangs. Rekluse products require the entire clutch pack be installed into the MAIN (deeper) basket slots. Installing the clutch pack into the “half slots” will cause performance issues. See the following picture for reference.*

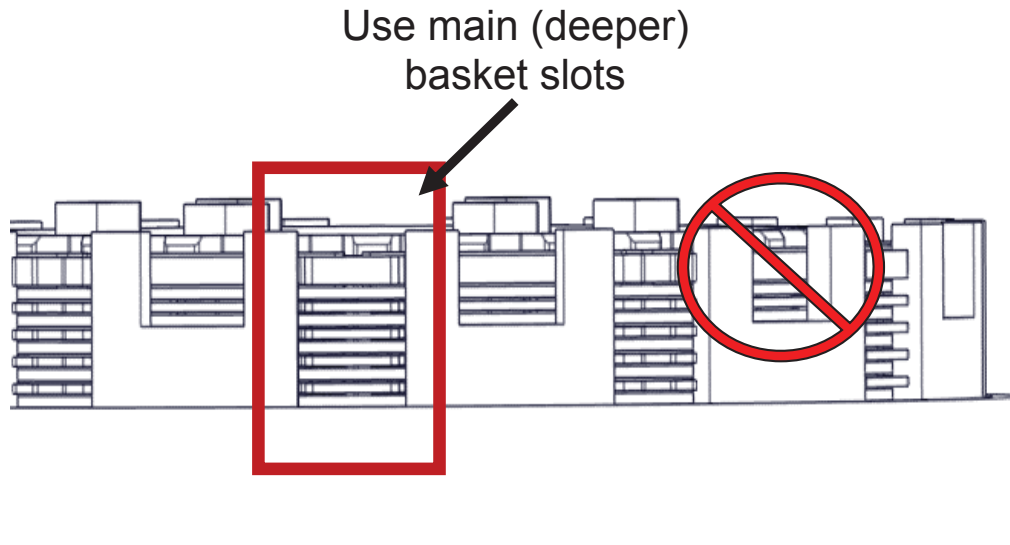

Install the clutch pack

1. Soak the Rekluse friction disks in new oil for at least 5 minutes. Make sure the friction disks are coated on both sides.

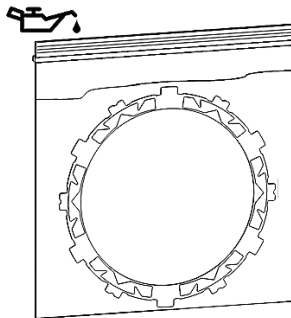

2. Inspect the clutch basket for notching. Do not install sleeves or use product with a notched basket. Notched basket tang faces can cause the sleeves to break. Do not use baskets that have been filed, machined, or modified on the tangs. Replace basket if necessary.

⚠ WARNING

Failure to inspect the basket and replace if necessary could result in death, serious injury, and/or property damage.

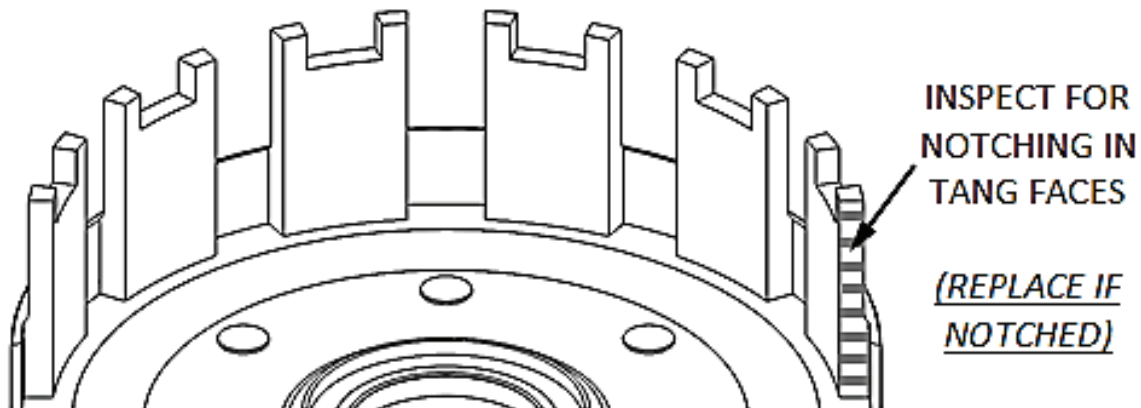

3. Install **ALL** the Rekluse basket sleeves into the basket slots. Make sure the sleeve tabs sit against the inside of the basket, then push the sleeves down until they contact the bottom of the tang slot. See pictures for reference.

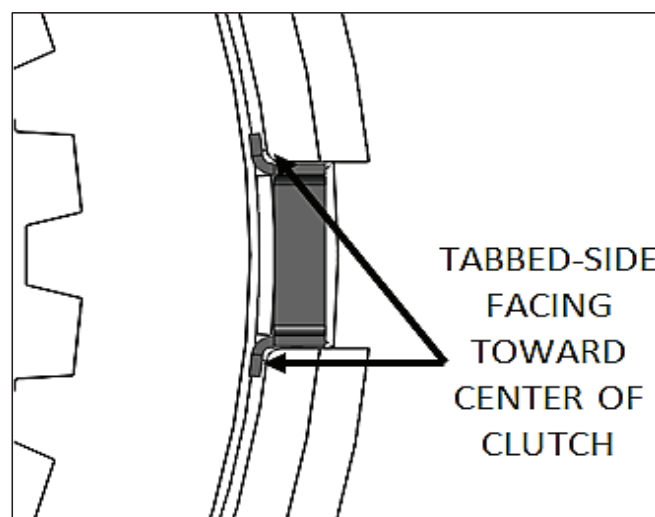

Install all the basket sleeves

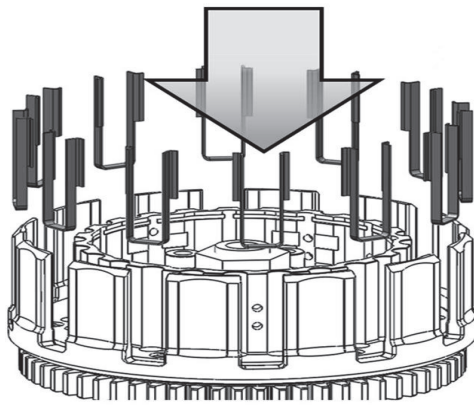

SLEEVE TOP MAY BE ABOVE OR BELOW BASKET TANG

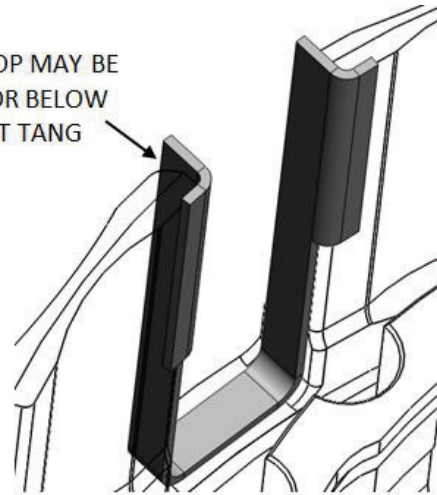

4. Install the Rekluse judder friction disk into the clutch basket.
5. Install the judder seat and then the judder spring onto the inner hub. The cupped side of the spring should face outwards.
6. Next, install a .048" (1.2 mm) steel drive plate followed by a thin friction disk.
7. Continue to alternate 5 additional - .048" (1.2 mm) steel drive plates with 5 additional thin friction disks.

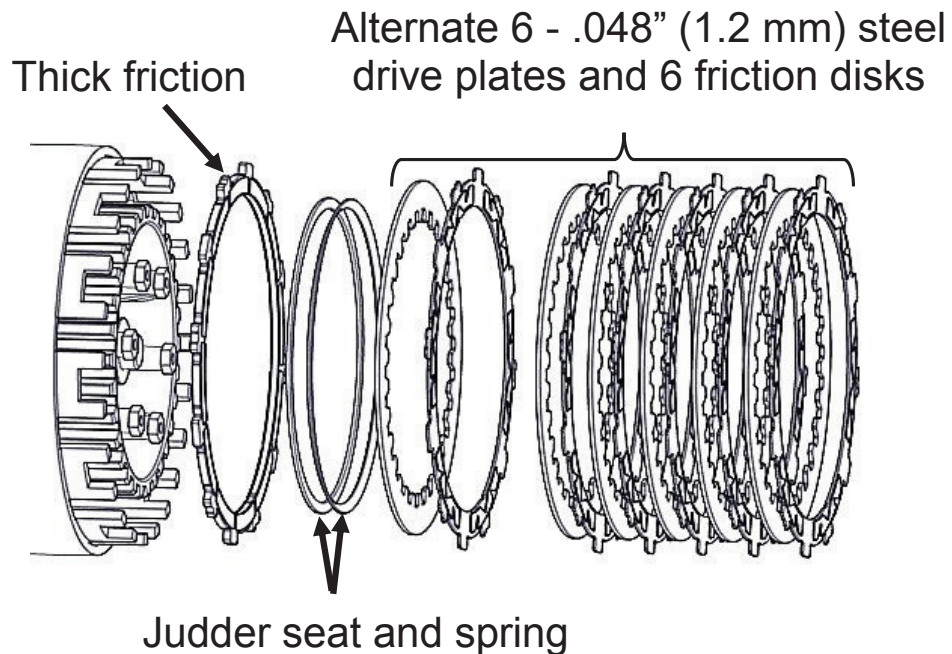

8. On top of the last friction disk, install a .040" (1.0 mm) steel drive plate.
9. Alternate the remaining 4 - thin friction disks with the remaining 4 .040" (1.0 mm) steel drive plates.
10. On top of the last steel drive plate, install the thick friction disk.

Alternate a total of 5 - .040" (1.0 mm) steel drive plates with 5 friction disks

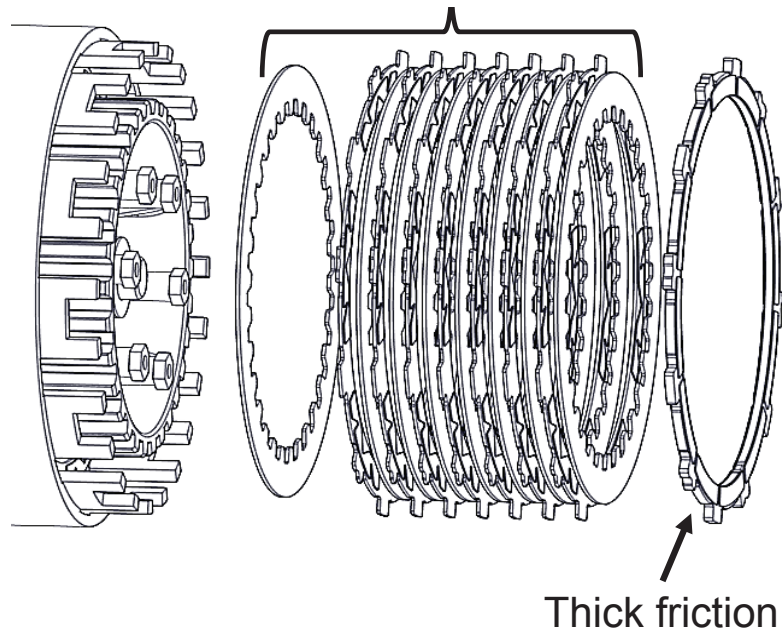

INSTALL PRESSURE PLATE

1. Reinstall the OE pressure plate.

NOTE: Verify the clutch lift rack has not fallen out of the pressure plate.

2. Install the Rekluse pressure plate springs.

3. Reinstall the OE pressure plate bolts.

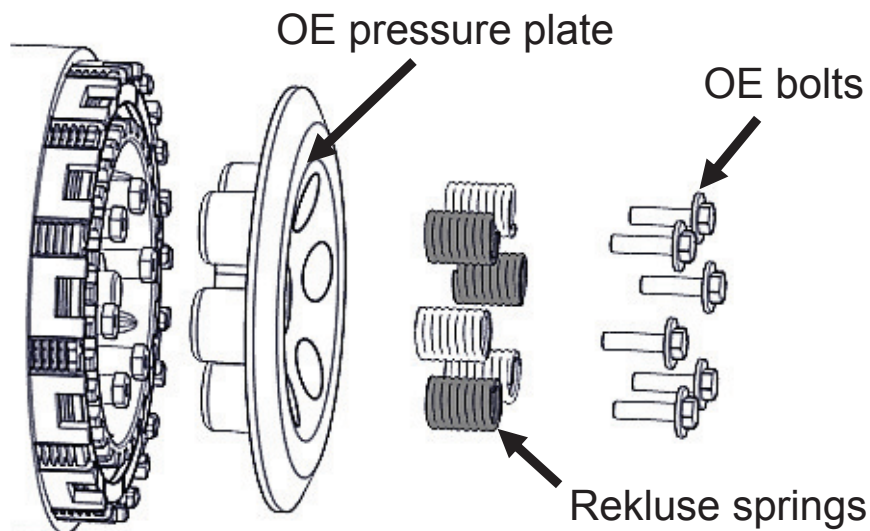

4. Loosely tighten the bolts, then torque them in a star pattern to **7 ft-lb (10 N-m)**.

5. Verify the shim is still located on the shift shaft.

6. Apply a thin layer of grease to the shift shaft seal before installing the primary cover.

7. Reinstall the primary cover, then lightly tightening the cover bolts in the following pattern. Tighten bolts in small

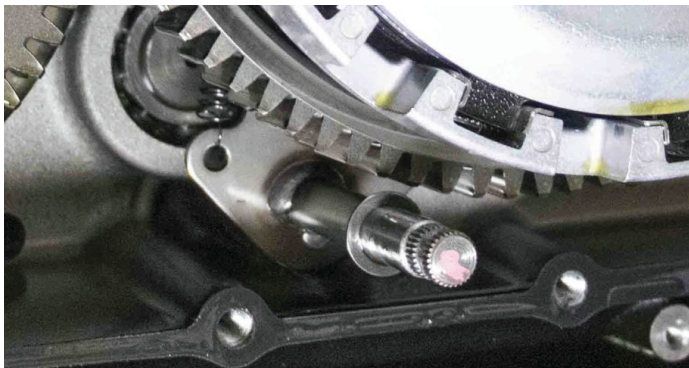

increments before torqueing the cover bolts to 15 ft-lbs (20 Nm)

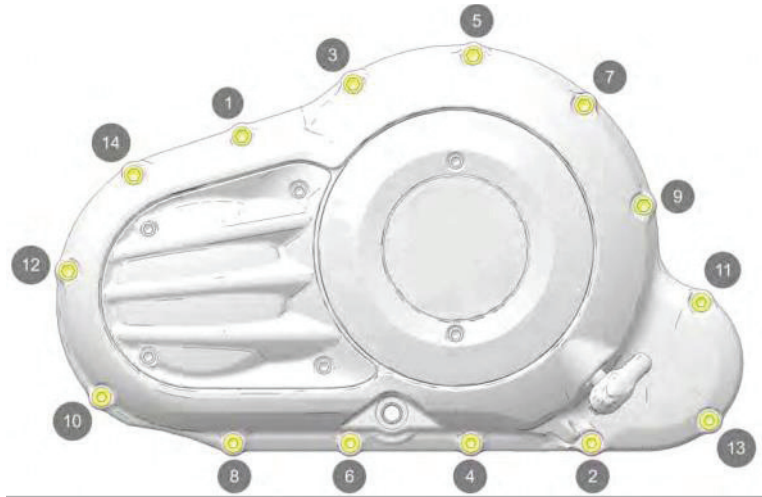

8. Reinstall the snap ring onto the clutch cable and install the clutch actuator arm.

NOTE: The clutch shaft must engage the clutch rack so the clutch actuator arm is angled approximately 60° off the primary cover mating surface.

9. Reinstall the clutch cable support.
10. Reinstall the shift linkage and floorboard assembly.
11. Reinstall both oil drain plugs and fill the oil to factory specifications.

MAINTENANCE

Clutch wear

Rekluse clutch packs are built using high quality materials but do wear based on the rider's use, type of terrain, and natural wear and tear.

- Clutch longevity and performance is greatly increased with oil quality and other bike factors that reduce engine heat.

- Riding style, such as speed, engine RPM, and terrain can also affect the life of the clutch pack.
- To keep your clutch performing at its best, perform regular maintenance on your bike and clutch based on your riding style.

Clutch parts

Inspect all your clutch parts at regular intervals for signs of wear or excessive heat and replace components as necessary.

- Measuring the clutch pack can help determine if the components need replacing. The clutch pack is measured with the entire clutch pack together. Include the friction pad in the measurement. See the **Setup Sheet at the back of the manual** for clutch pack measurements.

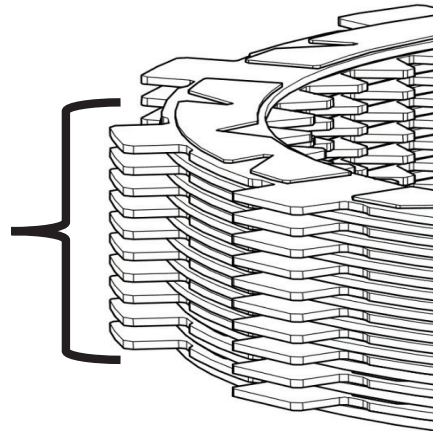

INSPECT THE CLUTCH PACK

Disk inspection examples: When inspecting the clutch pack, the following pictures can be used as a reference. **These are best viewed in color by viewing this install document on our website at www.rekluse.com/support.**

Drive Plates – If the clutch pack is getting high amounts of heat, purple, blue, or black color can be seen on the drive plate teeth. See pictures below. Not all drive plates look the same and may look different than pictured.



Normal Heat

High Heat
(Blue)

Excessive Heat
(Black)

Friction Disks – Due to the dark color of the friction material, the friction disks will appear almost black as soon as they are put in oil.

During inspection, look for glazing of the friction material. Glazing will appear shiny and feel like glass, even after oil is cleaned from the friction disk. Not all friction disks look the same and may look different than pictured.



Normal Friction



Glazed Friction

Preventive Maintenance

- For optimal clutch performance Rekluse recommends using fresh, clean oil that **meets JASO-MA** oil rating requirements. Rekluse offers Factory Formulated Oil™ developed specifically for Rekluse products. Rekluse Factory Formulated Oil is a perfect complement to any OEM or aftermarket wet clutch. Visit www.rekluse.com to learn more.

- Keep up with regular oil changes as per the bike manufacturer's recommendations. Clutch performance and longevity depend on oil quality.
- Change the oil filter and/or clean the oil screen with every oil change.

Basket:

- Inspect and replace basket sleeves if they appear to be notched from friction disks. Rekluse recommends replacing them every time friction disks are replaced.

NEED ADDITIONAL HELP?

Website

www.rekluse.com/support

Frequently asked questions

www.rekluse.com/faq

Support Videos

www.rekluse.com/support/videos

Phone

(208) 426-0659

Technical Support

Contact Technical Support for questions related to product installation, tuning, and performance.

Hours:

Monday thru Friday: 8:00 a.m. - 5:00 p.m.
Mountain Time zone

Email: tech@rekluse.com

Customer Service

Contact Customer Service for additional product information, orders, and returns.

Hours:

Monday thru Friday: 8:00 a.m. - 5:00 p.m.
Mountain Time zone

Email: customerservice@rekluse.com



198-2816100 SETUP SHEET

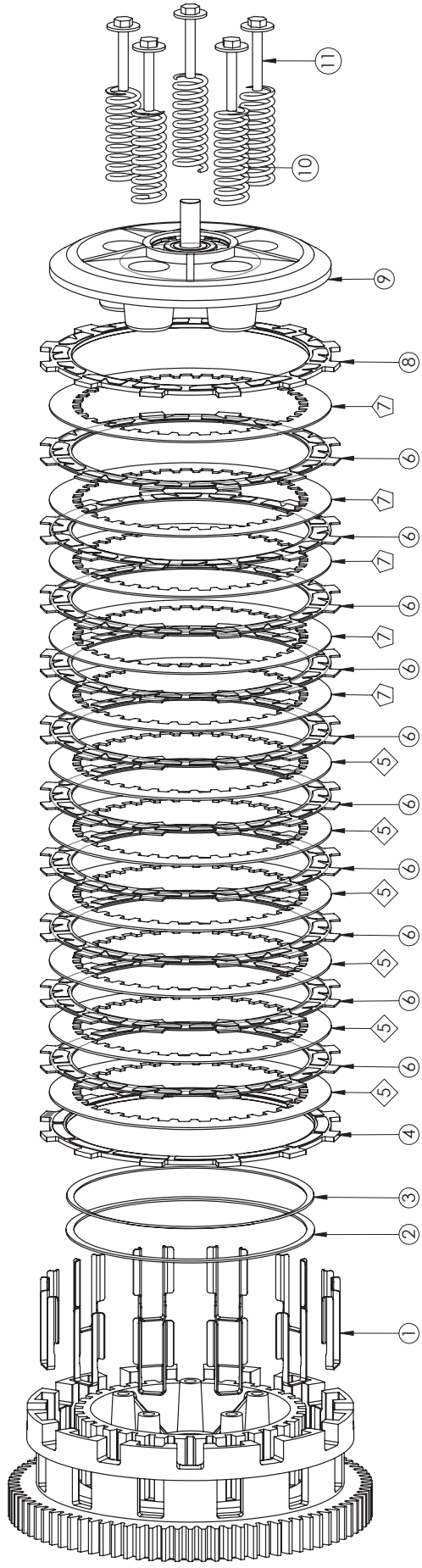

ITEM NO.	DESCRIPTION	QTY.
1	BASKET SLEEVES	12
2	OEM JUDDER SEAT	1
3	OEM JUDDER SPRING	1
4	JUDDER FRICTION THUNDER STROKE	1
5	.048" THICK DRIVE PLATE	6
6	THIN FRICTION THUNDER STROKE	10
7	.060" THICK DRIVE PLATE	5
8	THICK FRICTION - THUNDER STROKE	1
9	OEM PRESSURE PLATE	1
10	REKLUSE PRESSURE PLATE SPRINGS	5
11	OEM PRESSURE PLATE BOLTS	5

