

# SADDLEMEN®

WWW.SADDLEMEN.COM

## USER GUIDE & INSTALLATION INSTRUCTIONS

**DESCRIPTION:** R1300LXE Deluxe Roll Bag

**PART NUMBER:** 3515-0075

### OVERVIEW:

- Unexpanded- 16" L x 10"W x 9.5 H" with 1300 cu. in. (21 liters); expands to 20"x 10" x 9.5" and 1500 cu. in (24 liters) capacity.
- Wide top opening for easy packing.
- Internal mesh pockets help separate and organize contents.
- Rain cover for extra protection against the elements.
- Rigid construction looks great empty or full.
- Top and end carry handles and shoulder strap for easy toting off bike.
- Easy access zippered pockets on both ends, perfect for maps or other items you need while on the go.
- Versatile mounting system lets you install onto a luggage rack, back seat, sissy bar, and clips right onto most Saddlemen touring bags.
- Multiple D-Rings provide easy mounting options for hard-to-fit motorcycles.
- 1200 Denier SaddleTuff body panels are fully UV, water and weather-resistant.



### CONTENTS / PARTS INCLUDED:

<u>Qty</u>	<u>Item</u>	<u>Qty</u>	<u>Item</u>
1	R1300LXE roll bag	1	Rain Cover
1	Wide Sissy Bar Strap	1	Shoulder Strap
2	Cinch Strap w/ side release buckles	1	Instructions
2	Safety Strap w/ side release buckles & male side release half buckle		

### IMPORTANT:

All "NOTE," "CAUTION" and "WARNING" notations are serious safety issues and should be read carefully. Possible injury to riders or damage to the motorcycle and/or this bag may result if improperly installed.

### NOTICE TO DEALERS:

These instructions contain important information for future reference and should be given to the customer.

### CAUTION:

**READ THESE INSTRUCTIONS THOROUGHLY BEFORE INSTALLATION!**

Because of the variety of motorcycle configurations, other accessories, and the features and intended use of this Saddlemen accessory, there could be many different mounting options. You are responsible for the proper installation of this luggage onto your motorcycle. Your attention to these installation instructions and recommendations will permit safe and proper use of this accessory. You must mount this luggage properly and securely before riding your motorcycle. If you lack the ability to safely and properly install this bag, seek out a qualified motorcycle technician for assistance. During installation, support the motorcycle with a suitable stand or lift so it will not tip over and injure you, or damage the vehicle. Using or mounting this bag improperly could result in a loss of control of the motorcycle which could result in damage to your motorcycle or other personal property, the property of third parties, and/or personal injury to yourself or others, up to and including death.

IS-4110520A 3515-0075 (07/2022)

## CAUTION:

BE SURE TO THOROUGHLY READ AND CLOSELY FOLLOW THE MOUNTING INSTRUCTIONS THAT ARE INCLUDED WITH THIS LUGGAGE:

- Do not use this bag if any part of the mounting system has deteriorated, loosened or is beginning to fail. If you have any doubts as to the security of bag's installation, stop using it.
- This bag can also be attached in many locations on the motorcycle using several different combinations of the straps provided inside the R1300X-LE or using bungee cords. It is beyond the scope of these instructions to describe the multiple locations available on the many different motorcycle brands and models. For every installation, it is critical that the bag is securely mounted so that it cannot shift during operation and that no part of the bag or the mounting system can touch any moving part of the motorcycle, the drive train or controls during operation.
- After every stop check the bag to be certain that it did not shift while riding and verify that the straps will not contact or interfere with any part of the drivetrain, suspension, brakes or wheels.
- Do not exceed 10 pounds total weight of bag, contents and attachments or the load limits of the motorcycle as specified in the owner's manual supplied with the bike or from the bike manufacturer.
- When the bag is removed, all loose straps must be removed from the motorcycle, or secured, so that they do not contact or interfere with any part of the drivetrain, suspension, brakes or wheels before operating the motorcycle.
- Always remove or stow all shoulder and backpack straps before attaching bag to motorcycle.
- If you do not understand the mounting instructions or this warning label DO NOT mount this bag. Contact your local professional motorcycle dealer for assistance, or call the Saddlemen support line at (310) 638-1222.

DO NOT ATTEMPT TO USE THIS LUGGAGE IF:

- You do not understand these installation and use instructions,
- You do not understand any part of the accessory mounting system,
- You have any doubts as to the security of the mounting system.

If you have any concerns or questions, seek help at a qualified motorcycle dealer or call the Saddlemen support line at (310) 638-1222.

To avoid injury, install while engine is cold.

## INSTALLATION:

1. D-rings on each side of the bag are provided as anchor points for the different straps included, or for bungee cords. Straps or cords routed through these rings can attach the R1300LXE bag to the seat, luggage rack or sissy bar using any rigid mounting points (frame, grab rails, etc) on the motorcycle.

2. Two sets of webbing are sewn on the back of each bag, between the elastic covered side release buckles. These can be used to route and hold two of the supplied safety straps. These two straps can be tightened around a sissy bar with the bag resting on the seat or a rear mounted rack. Connect the two straps into the elastic covered side release buckles, and loop them around some secure, rigid mounting points, to hold the bag against the seat or rack and to keep the bag from moving up or down during operation of the motorcycle.

3. This bag can be installed on top of most Saddlemen sissy bar bags, by using the four buckles attached to the top of the larger bag. Release the side release buckles and fit the male portion into the buckle receiver that is under the elastic straps on the sides of the R1300LXE bag and then repeat for the other male / female set on the opposite side of both bags.

4. If bag is set against a painted surface, it can scuff or scratch the paint. Saddlemen offers a Protective Tape Kit (p/n 4320-0807) that can be placed over paint to protect the finish if your desired mounting location causes the bag to contact painted surfaces.

NOTE: DO NOT connect any straps to flexible or moving parts (i.e., rubber mounted turn signals or handlebars).

NOTE: You must tuck away, tie, or cut/shorten all loose mounting straps that might interfere with operation BEFORE you ride the motorcycle. Use a safe heat source to lightly seal the strap's cut edge.

NOTE: Check bag mounting strap tightness each time you stop.

DO NOT OVER TIGHTEN THE MOUNTING STRAPS: Overtightening the mounting straps can cause the D-rings to separate from the bag. Use additional mounting straps rather than overtightening the straps.

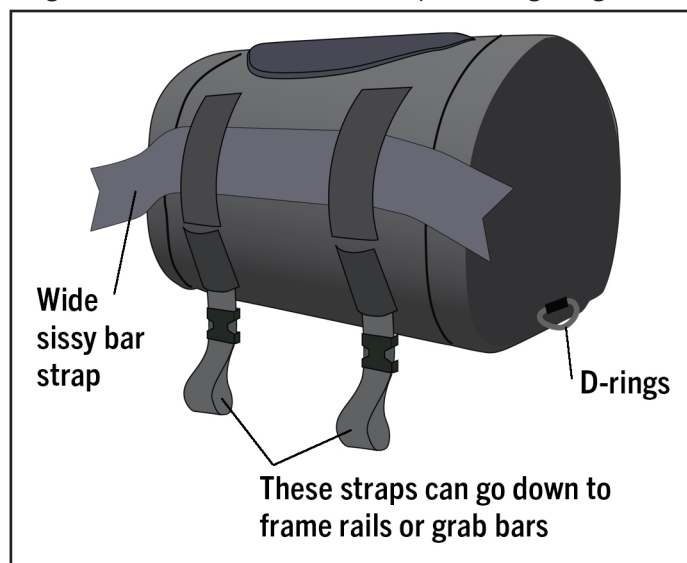

IS-4110520A 3515-0075 (07/2022)

## CAUTION:

**IMPORTANT:** Failure to install this accessory properly may allow portions of the bag or its mounting straps to contact the vehicle's moving parts. It is vital that you verify that this bag and/or any of its parts will not touch, or interfere as the motorcycle's suspension moves through its entire range of motion. Make sure that your Roll Bag does not touch the exhaust or other non-moving components, as well, as it may be damaged from such contact. Occasionally, the configuration of this accessory with certain motorcycles may require relocation and/or adjustment of certain components on the vehicle. Check to be sure that all lights and safety reflectors are visible once the bag is in place. If the bag blocks any side reflectors, place reflectors on the exterior sides of the bag (reflectors with self-adhesive backing are available from motorcycle or automobile supply stores). It is your responsibility to make sure installation does not create an unsafe or illegal situation. Remember: Motorcycling can be a dangerous activity. Installation of any accessory can increase your risk if it is not installed properly. You are responsible to install this accessory so it will not contact any portion of the drive train, suspension or steering, or if it will in any way interfere with the operation of your motorcycle.

## IMPORTANT:

After 50 miles (80 kilometers), recheck the security of all mounting straps. Inspect periodically during normal maintenance checks thereafter. Inspect the bag and related hardware before, and during, each ride. A loose bag or hardware can interfere with the vehicle's operation and cause an unsafe riding condition.

## NOTE:

**CARE AND CLEANING** Your Saddlemen bag requires almost no maintenance other than periodic cleaning with mild soap and water and the application of a UV inhibitor to prevent color fading caused by UVA and UVB sun exposure. We recommend Ray Bloc Fabric Protector or a similar product, which can be purchased online or at your local home improvement store. Fading due to lack of maintenance is not covered by warranty.

## LIMITED WARRANTY POLICY

**SADDLEMEN LIMITED ONE-YEAR WARRANTY** Saddlemen warrants its products for defects in materials, design or workmanship for a period of one year after retail purchase. Items that are defective will be repaired or replaced by Saddlemen at its sole discretion. Damage caused by improper use or improper installation is not a defect; therefore repair, replacement or shipping of a damaged accessory will not be covered under this warranty. This limited warranty contains other provisions and conditions, so please refer to the Warranty Policy that was provided with your luggage or visit [www.saddlemen.com](http://www.saddlemen.com) for additional information. You can count on Saddlemen's quality, innovation, service and style. If for any reason you are not satisfied with the performance of your Saddlemen luggage, please contact the Saddlemen support line at (310) 638-1222.

IS-4110520A 3515-0075 (07/2022)