

SADDLEMEN®

W W W . S A D D L E M E N . C O M

USER GUIDE & INSTALLATION INSTRUCTIONS

DESCRIPTION: S-RT Mini Fairing **PART NUMBER:** Saddlemen 818-29-15589 Drag Specialties 2330-0307

FITMENT: H-D® Softail® 2018-2020 Low Rider, 2018-2023 Street Bob and Softail Standard

Will not fit: Low Rider S/ST, Fat Bob, Fat Boy, Breakout, Heritage Classic

OVERVIEW:

The Saddlemen S-RT Mini Fairing has an instantly recognizable profile, but in a slimmer, performance-oriented package. This fairing adds just the right amount of wind protection while creating an unmistakable style. The included inner fairing dash panel finishes the look.

The S-RT Mini's durable ABS construction comes with a gloss black painted finish. Each specific fit fairing kit includes powder coated brackets and stainless steel hardware, and bolts to your bike without any modifications (some bikes may require taller handlebar risers). The list of features includes a clear headlight cover and an 8" tall, light smoke tinted windscreen. Features include:

- Durable ABS construction with a gloss black painted finish
- Direct fit bolt-on installation, with no modifications to bike required* (some models may need to change handlebars or risers)
- Included: 8-inch tall light smoke windscreen, clear headlight cover lens, powder coated steel brackets and stainless steel hardware

IMPORTANT:

Please read these instructions completely before starting installation. All "NOTE," "CAUTION" and "WARNING" notations are serious safety issues and should be read carefully. Possible injury to riders or damage to the motorcycle and/or accessory may result if improperly installed.

NOTICE TO DEALERS:

These instructions contain important information for future reference and should be given to the customer.

⚠ WARNING:

READ THESE INSTRUCTIONS THOROUGHLY BEFORE INSTALLATION!

This is a specific fit accessory and is only meant to fit certain motorcycle models. You are responsible for the proper installation of this accessory on your motorcycle. Your attention to these installation instructions, any additional specific instructions and recommendations will permit the safe and proper use of this accessory. You must mount this accessory properly and securely before riding your motorcycle. If you lack the ability to safely and properly install this accessory, seek out a qualified motorcycle technician for assistance. During installation, you may need to support the motorcycle with a suitable stand or lift so it will not tip over and injure you, or damage the vehicle. Using or mounting this accessory improperly could result in a loss of control of the motorcycle which could result in damage to your motorcycle or other personal property, the property of third parties, and/or personal injury to yourself or others, up to and including death.

BE SURE TO THOROUGHLY READ AND CLOSELY FOLLOW THE MOUNTING INSTRUCTIONS THAT ARE INCLUDED WITH THIS ACCESSORY.

- If you do not understand these instructions **DO NOT** mount this accessory, and remove any related components you may have already installed on your motorcycle.
- Thoroughly inspect your motorcycle and all accessories before every ride. Do not use this fairing if its mounting system has been modified, has deteriorated, loosened or is beginning to fail.
- Continually check the security of this and all other accessories at each stop as you ride. Items attached to your motorcycle can loosen during operation, so be sure to check them frequently.
- Do not use this fairing if you have any doubts as to whether it is properly mounted to your motorcycle. You must be sure that the installation of the accessory will not damage your motorcycle's painted or plated parts. Saddlemen is not responsible if you or your technician mount this accessory and it damages your motorcycle for any reason.
- When using any accessory, do not exceed your vehicle's Maximum Gross Vehicle Weight as listed on your motorcycle or in the manufacturer's owner's manual.
- If this accessory is ever damaged, remove it and do not use it until it has been inspected by your local professional motorcycle dealer. Replace any mounting part immediately if it has sustained damage that will prevent it from being properly secured to your motorcycle.

DO NOT ATTEMPT TO USE THIS ACCESSORY FAIRING IF:

- You do not understand these installation and use instructions;
- You do not understand any part of this accessory's mounting system;
- You have any doubts as to the security of the mounting system.
- If you have any concerns or questions, seek help at your qualified motorcycle dealer or call the Saddlemen support line at (310) 638-1222.

11-400476 S-RT Mini Fairing, Softail (Rev 1 2-2024)

CONTENTS / PARTS INCLUDED:

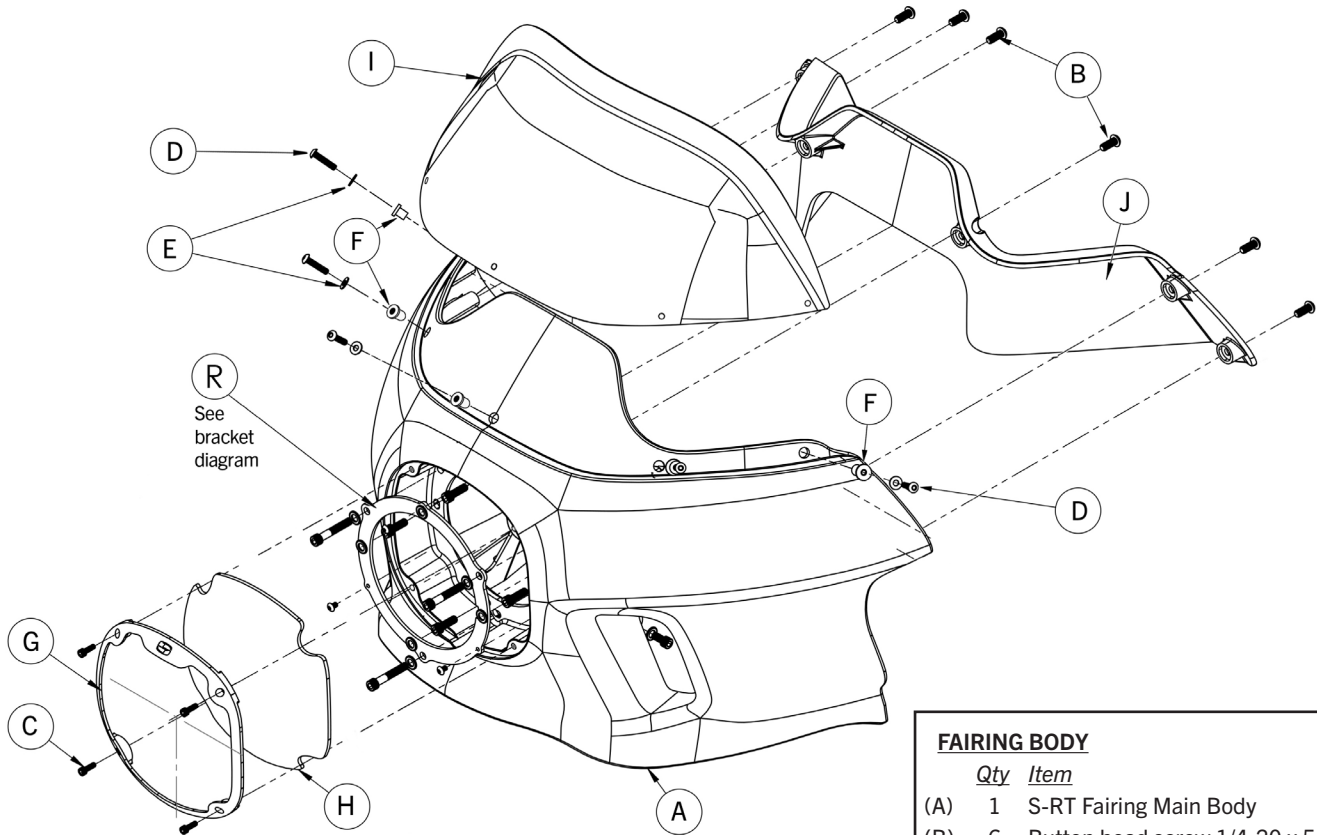

FAIRING BODY

| Qty | Item |
|-----|-----------------------------------|
| (A) | 1 S-RT Fairing Main Body |
| (B) | 6 Button head screw 1/4-20 x 5/8" |
| (C) | 4 Socket head screw 8/32 x 1/2" |
| (D) | 5 Button head screw 10/32 x 7/8" |
| (E) | 5 Nylon plastic washers |
| (F) | 5 Rubber/brass well nut 10/32 |
| (G) | 1 Headlight bezel trim |
| (H) | 1 Headlight lens |
| (I) | 1 Windshield, light tint |
| (J) | 1 Inner fairing |

BRACKET ASSEMBLY

| Qty | Item |
|-----|---|
| (K) | 1 Main Bracket Assembly |
| (L) | 2 Washer, 3/8" stainless steel |
| (M) | 1 Nylon insert locknut 3/8-16 |
| (N) | 7 Nylon insert locknut 1/4-20 |
| (O) | 15 Washer, 1/4" stainless steel |
| (P) | 1 Socket head screw 1/4-20 x 3/4" |
| (Q) | 1 Aluminum spacer |
| (R) | 1 Mounting ring |
| (S) | 3 Socket head screw 1/4-20 x 1-1/2" |
| (T) | 1 Headlight trim ring for 5.75" headlight |
| (U) | 3 Button head screw 8/32 x 1/4" |
| (V) | 3 Steel compression springs .875" |
| (W) | 4 Socket head screw 1/4-20 x 3/4" |
| (X) | 1 Socket head bolt 3/8-16 x 4.5" |

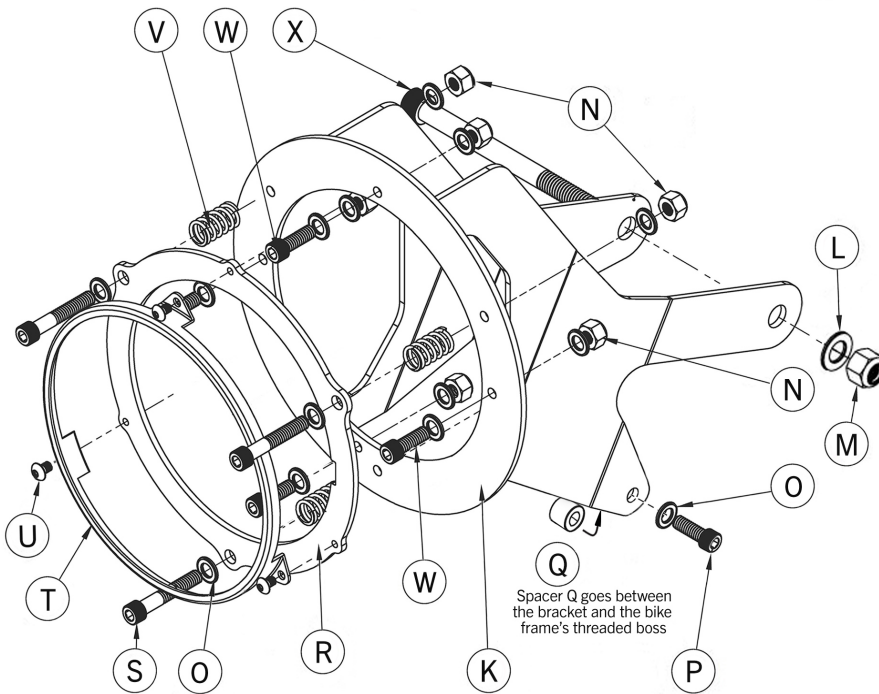

⚠ WARNING:

Remember: Motorcycling can be a dangerous activity. Installation of any accessory can increase your risk if it is not installed properly. You are responsible to install this accessory so it will not contact any portion of the drive train, suspension or steering, or if it will in any way interfere with the operation of your motorcycle.

To avoid injury, install while engine is cold.

INSTALLATION:

This S-RT Fairing kit should allow you to reuse your stock 5.75" headlight.

If you need a new headlight, or are just looking for an upgrade, we recommend NAMZ Custom Cycle (www.namzcustomcycleproducts.com) 5.75" headlight options LLC-LH-5B, LLC-DHL-5TS or LLC-LHC-5B.

INSTALLATION NOTES

Your S-RT Fairing came pre-assembled in the box. You'll need to disassemble some of it for installation on your motorcycle. Take note of any hardware you remove from the fairing, as it will be reused for installation.

- Remove the Headlight Bezel Trim (G), and the Headlight Lens (H), from the Fairing.
- Remove the hardware holding on the Headlight Trim Ring (T) and the Mounting Ring (R). You should now be able to remove the Fairing Main Body (A) from the Main Bracket Assembly (K).

Once the Fairing Main Body is separated, you can begin to install the Main Bracket Assembly onto your motorcycle.

MOUNT FAIRING BRACKET TO MOTORCYCLE FRAME

1. Remove and disassemble your bike's headlight. You will reuse the headlight lamp.
2. See Fig. A. Remove the front mounting bolt from your motorcycle's fuel tank. Your gas tank will share the front mounting points with the S-RT Fairing Main Bracket.
3. Slide the Main Bracket Assembly (K) between the fork tubes and onto the bike's frame. Using the long bolt (X), washer (L) and locknut (M), bolt the Main Bracket Assembly (K) to the motorcycle frame at the points shown in Fig. A. Ensure that no hoses, wires or cables are pinched. Leave all hardware loose for now.
4. See Fig. A. Using socket head screw (P) and washer (O), attach the lower bracket arm to the left side of the frame, with the spacer (Q) in between the bracket and the bike's frame.

MOUNT FAIRING BODY ONTO MAIN BRACKET

5. See Fig. B. Push four bolts (W) with washers (O) through the Fairing Main Body (A) and through the Main Bracket Assembly (which you've already bolted to the motorcycle frame). Using four corresponding locknuts (N) with washers (O) on the backside, attach the Fairing to the Main Bracket Assembly. The Fairing holes are slotted to allow for minor adjustments to perfectly level your fairing.

Continued next page...

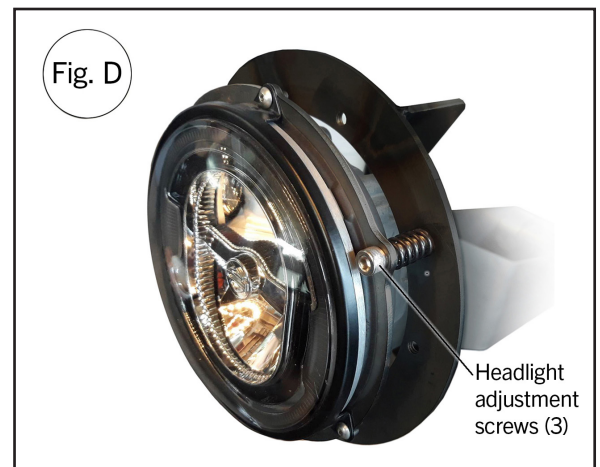
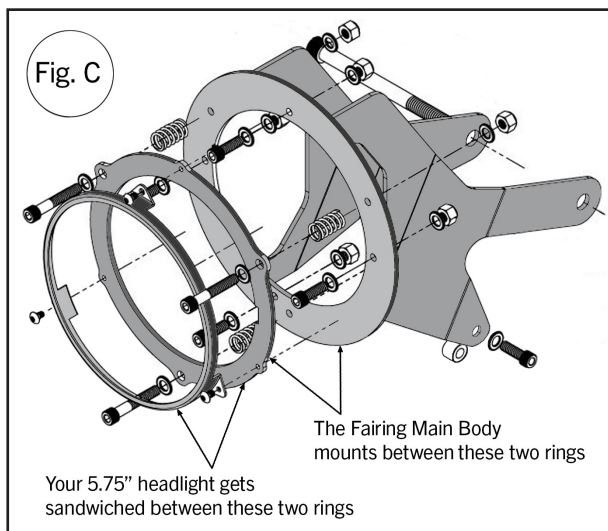
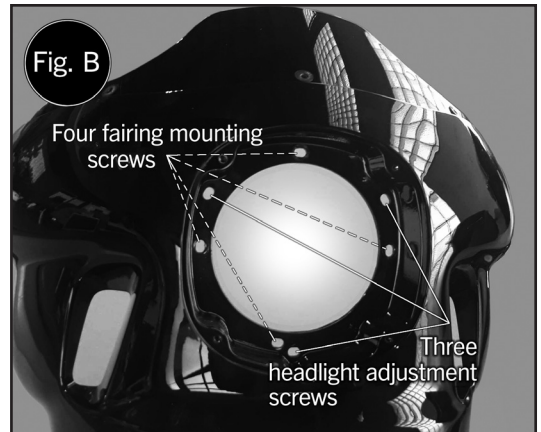
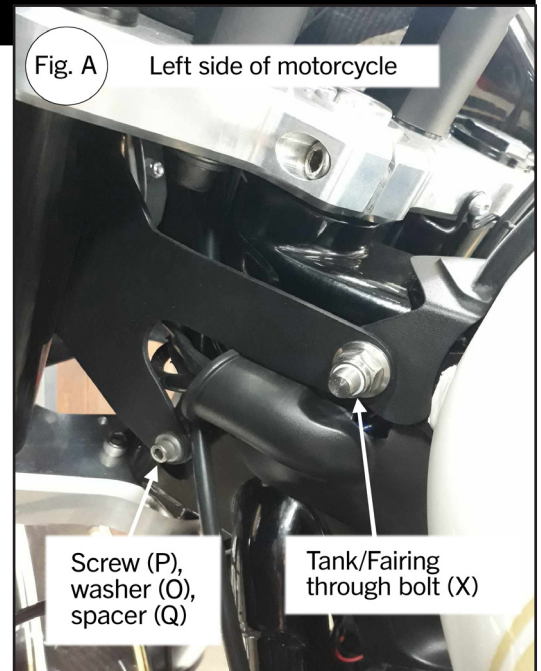

11-400476 S-RT Mini Fairing, Softail (Rev 1 2-2024)

INSTALLATION *(continued)*

INSTALL HEADLIGHT

6. See Fig. C. Install your 5.75" headlight (not included) using three small screws (U), and attaching the Headlight Trim Ring (T) to the Mounting Ring (R) with the headlight lamp sandwiched between the two rings. The headlight should have a notched that matches with a notch in the Mounting Ring (R). For reference, see Fig. D.
7. The headlight sub-assembly mounts to the Main Bracket Assembly (K) using three screws (S), and three washers (O) going through the Mounting Ring. Slide a Compression Spring (V) over each screw, then screw it through the Fairing Body and into the Main Bracket ring, with a washer (O) and locknut (N) behind it. These three screws will provide your headlight angle adjustment.
8. Plug in your headlight wires.
9. Install the Inner Fairing (J) using six screws (B).
10. Install the Headlight Lens (H) and Headlight Bezel Trim (G) using four socket head screws (C).
11. Install the windshield, by first inserting the five rubber/brass well nuts (F) into the five corresponding holes in the Main Fairing Body.
12. Using five 10/32" button head screws (D) and plastic washers (E), attach the windshield to the fairing body.
13. Re-read these instructions, tightening all fasteners along the way.

FINAL CHECKLIST

- Adjust the three screws (S) to set the proper headlight angle.
- Check all clearances for handlebars, mirrors, etc. at both left and right steering stops as well as your forks' full compression.

WARNING:

- It is vital that you verify that this accessory and/or any of its parts will not touch, or interfere with other components while the suspension and steering move through their entire range of motion. Make sure that neither the fairing nor its mounting hardware interfere with any other parts of the motorcycle in the course of operation, as they might be damaged from contact with the accessory.
- The configuration of this accessory fairing with certain motorcycles may require relocation and/or adjustment of certain components on these vehicles, including handlebars, mirrors, and lights. Check to be sure that all lights, turn signals, mirrors and safety reflectors are in place once the fairing is installed. If the fairing installation blocks or interferes with the turn signals, you will need to move the turn signals to another mounting point that permits their proper electrical function and visibility. If the fairing or mounting hardware blocks any side reflectors, place new reflectors on the exterior sides of the fairing. Reflectors with self-adhesive backing are available from motorcycle or automobile supply stores. It is your responsibility to make sure that the installation of this accessory does not create an unsafe or illegal condition.
- Improperly installed or loose hardware can allow the fairing to move. Before riding, visually check the clearance between the fairing and any moving parts that could impair normal operation of the motorcycle.

CAUTION:

It is your responsibility to make sure this accessory installation does not create an unsafe or illegal situation. Remember that this is a custom accessory. You must check the installation to determine if it will be safe for you to operate the motorcycle safely and legally. You must also ensure that the installation does not damage your vehicle in any way.

After 50 miles (80 kilometers), recheck all of the fairing mounting hardware and the fairing to make sure they are still tight and secure. Loose hardware can cause the fairing to interfere with the vehicle's operation and can cause an unsafe riding condition. After that, check fastener tightness during each regular maintenance check.

LIMITED WARRANTY POLICY

SADDLEMEN LIMITED ONE-YEAR WARRANTY Saddlemen warrants its products for defects in materials, design or workmanship for a period of one year after retail purchase. Items that are defective will be repaired or replaced by Saddlemen at its sole discretion. Damage caused by improper use or improper installation is not a defect; therefore repair, replacement or shipping of a damaged accessory will not be covered under this warranty. This limited warranty contains other provisions and conditions, so please refer to the Warranty Policy that was provided with your Saddlemen product or visit www.saddlemen.com for additional information. You can count on Saddlemen's quality, innovation, service and style. If for any reason you are not satisfied with the performance of your Saddlemen accessory, please contact the Saddlemen support line at (310) 638-1222.

11-400476 S-RT Mini Fairing, Softail (Rev 1 2-2024)