

# SADDLEMEN®

WWW.SADDLEMEN.COM

## USER GUIDE & INSTALLATION INSTRUCTIONS

**DESCRIPTION:** Tour Step-Up™ seats for Harley-Davidson®

**PART NUMBERS:** All

### OVERVIEW:

Congratulations on choosing a new Saddlemen® seat for your motorcycle! Your new seat will give your bike an immediate improvement in comfort and style. All Saddlemen seats are constructed with a heavy-duty plastic or fiberglass pan, with durable rubber bumpers and plated brackets that often exceed the strength and durability of the original seat's components.

### IMPORTANT:

Please read these instructions completely before starting installation. All "NOTE" "CAUTION" and "WARNING" notations are serious safety issues and should be read carefully. Possible injury to riders or damage to the motorcycle and/or accessory may result if improperly installed.



### NOTICE TO DEALERS:

These instructions contain important information for future reference and should be given to the customer.

### ⚠ WARNING:

Because of the variety of motorcycle configurations, other accessories, and the features and intended use of this Saddlemen seat, there may be different mounting options. You are responsible for the proper installation of this seat on your motorcycle. Your attention to these installation instructions, any additional specific instructions and recommendations will permit the safe and proper use of this seat. You must mount this seat properly and securely before riding your motorcycle. If you lack the ability to safely and properly install this seat, seek out a qualified motorcycle technician for assistance. During installation, you may need to support the motorcycle with a suitable stand or lift so it will not tip over and injure you, or damage the vehicle. Using or mounting this seat improperly could result in a loss of control of the motorcycle which could result in damage to your motorcycle or other personal property, the property of third parties, and/or personal injury to yourself or others, up to and including death.

**PASSENGER GRAB STRAP:** This accessory seat is provided without a passenger grab strap. Carrying a passenger without a grab strap in place on your motorcycle may be hazardous for the passenger. Grab straps, rear mounted foot pegs, sissy bars, passenger backrests and trunks aid in making a passenger more secure on the vehicle. Laws in some jurisdictions require grab straps or other security devices when a passenger is transported. Do not transport a passenger if they are not secure. Do not disable grab straps or other safety features provided on your motorcycle and obey all traffic laws while riding.

Saddlemen offers a complimentary grab strap for this seat, part no. 15327. Call (310) 638-1222 for more information. Always ride responsibly and take precautions to be sure your passenger is secure and comfortable at all times.

⚠ California Proposition 65 Warning

**WARNING:** This product contains chemicals known to the State of California to cause cancer and birth defects or other reproductive harm. For more information: [www.P65/Warnings.ca.gov](http://www.P65/Warnings.ca.gov)

**BE SURE TO THOROUGHLY READ AND CLOSELY FOLLOW THE MOUNTING INSTRUCTIONS THAT ARE INCLUDED WITH THIS SEAT.**

- The seat must be installed and securely fastened onto the chassis of the motorcycle. Refer to your motorcycle's Owner's Manual and/or Service Manual for guidance.
- If you do not understand these instructions DO NOT mount the seat, and remove any related components you may have already installed on your motorcycle.
- Thoroughly inspect your motorcycle's seat before every ride. Do not use this seat if its mounting system has been modified, has deteriorated, loosened or is beginning to fail.
- Continually check the security of your seat and other accessories at each stop as you ride. Items attached to your motorcycle can loosen during operation, so be sure to check them frequently.
- Do not use this seat if you have any doubts as to whether it is properly mounted to your motorcycle. You must be sure that the installation of the seat will not damage your motorcycle's painted or plated parts. Saddlemen is not responsible if you or your technician mount the seat and it damages your motorcycle for any reason.
- When using any accessory, do not exceed your vehicle's Maximum Gross Vehicle Weight as listed on your motorcycle or in the manufacturer's owner's manual.



IS-11-400243 Tour Step Up (04-2023)

## ⚠ WARNING:

• If your seat is ever damaged, do not use it until it has been inspected by your local professional motorcycle dealer. You may also need to send your seat to Saddlemen for inspection or repair. Replace any mounting part immediately if it has sustained damage that will prevent the seat from being properly secured to your motorcycle.

DO NOT ATTEMPT TO USE THIS SEAT IF: • You do not understand these installation and use instructions; • You do not understand any part of the seat's mounting system; • You have any doubts as to the security of the seat's mounting system.

• If you have any concerns or questions, seek help at your qualified motorcycle dealer or call the Saddlemen support line at (310) 638-1222.

Remember: Motorcycling can be a dangerous activity. Installation of any accessory can increase your risk if it is not installed properly. You are responsible to install this seat or any accessory so it will not contact any portion of the drive train, suspension or steering, or if it will in any way interfere with the operation of your motorcycle.

## INSTALLATION:

In most cases, your new seat will install the same way as the original seat. Consult your motorcycle's owner's manual to remove the seat, and replace it with the Saddlemen seat.

In some cases, it may be necessary to remove mounting hardware and rubber bumpers from your original seat and reinstall them on your new seat. Our seat base design may differ slightly from your original pan because your original brackets and hardware will mount onto the new seat with new bolts (supplied with this seat). Because of manufacturing variances between different models and years, it may be necessary to slightly alter the bolt-hole size on the original brackets with a drill or file to accommodate the new bolts. Seats that require unique mounting will have instruction labels affixed to the seat or a supplemental instruction set will be included.

For most motorcycles, your new Saddlemen seat installs to your bike by inserting a front bracket into the bike's frame below the gas tank, and a single screw secures the seat to the bike's rear fender (see Fig. A).

1. Remove the original seat and place it bottom side up next to your new custom replacement seat.
2. If applicable, remove the brackets from your original seat and install them in the corresponding location on your new seat, using the bolts provided. Install the new bolts through the brackets and into the threaded inserts in the new seat bottom. Repeat until all hardware is transferred.
3. See Fig. B. If your Saddlemen seat uses a single mounting bracket at the rear, you may need to remove the two bolts holding on the bracket, and reinstall it with the tongue in the installation position.
4. Check all fasteners for tightness, 10 -to- 15 ft/lbs torque is recommended, do not overtighten.
5. **2014 and later H-D Touring models** have two metal frame bumpers on either side of the battery (see Fig. C) that should be removed prior to installing your Saddlemen seat.
6. **Some H-D CVO Touring models** may have come with two trim pieces that are glued to the top of the rear fender with adhesive tape. Some Saddlemen seats will not be compatible with these fender trim pieces. If the trim pieces interfere with the installation of your new seat, remove them with a paint-safe adhesive remover product, or a hair dryer to heat up the adhesive and make removal easier.
7. **Some motorcycle models** require the special specific bumpers from your original seat to be removed and installed onto the Saddlemen seat for proper tolerance and fit. The stock bumpers are easily removed by twisting and pulling at the same time. Reinstallation requires drilling a hole of the same diameter as the original into the new seat pan. Rubber bumpers are most easily installed using either water or silicone spray as a lubricant.
8. Reinstall the seat on the motorcycle. Check to make sure the seat fits properly. The new seat will be firmer than the original seat and will break-in over time to provide greater comfort (usually several hundred miles of riding is required). During the break in, the seat will also settle in, or lower, about ½ to one inch. Older seats may seem substantially lower because of the worn-out, compressed foam that may have deteriorated with time.

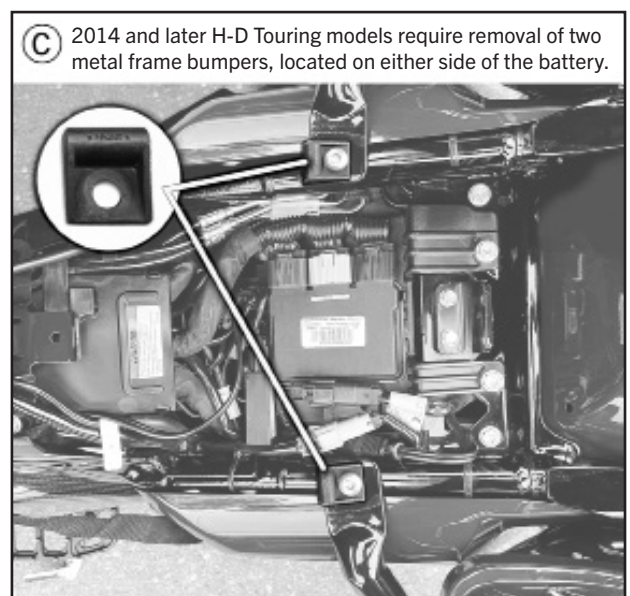
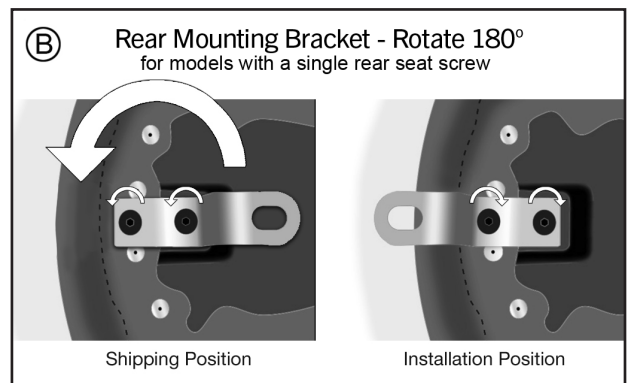
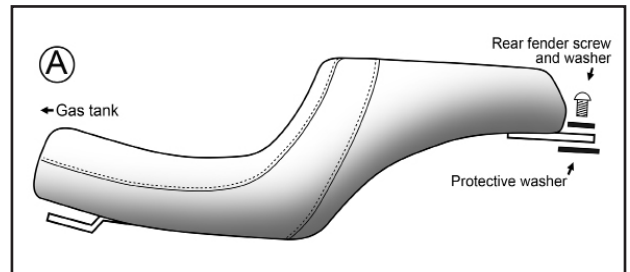

IS-11-400243 Tour Step Up (04-2023)

# INSTALLATION *(continued)*

## OPTION: REMOVABLE BACKREST - ADJUSTMENT AND OPERATION

If your seat was ordered with the Driver's Backrest option, there will be hardware inside the seat to receive the backrest bar. Access is through a slot (sometimes covered by a flap) located on the seat top behind the driver's lumbar support. The metal backrest bar will get inserted into this sleeve and can then be adjusted both vertically or fore and aft.

1. **Backrest Pad Spacer (optional)** See Fig. E. The backrest pad attaches to the backrest bar pivot mount using two screws. There is an optional spacer included with this seat, which installs between the pivot mount and the backrest pad. This spacer moves the backrest pad forward if desired by the rider. Remove the two screws on the pivot mount, and reinstall the pivot mount to the backrest pad using the new spacer and two longer screws provided with this seat.

2. **Installation** Grasp the backrest bar and slide it into the hidden metal sleeve. You should feel it click into place. If the backrest bar is "floppy" after insertion, it is not inside the metal sleeve. Remove and reinstall, making sure it is firmly in the correct position.

3. **Adjust Height** The height of the backrest is adjustable to one of several positions, determined by detents on the backrest bar. Adjust the pad's height by firmly grasping the bar and lower or raise it to the desired height.

4. **Adjust Fore/Aft Position** The fore/aft position of the backrest unit is adjusted by a thumb screw located under the backrest pad on the backrest bar. It is accessible through a hole in the backrest bar soft cover. Turning the screw in or out will change the bar angle. This can slant the pad fore or aft by up to three inches. The most common and suggested starting position is with the backrest aligned directly above, and at the same angle as, the upward portion of the driver's lumbar support. When you have adjusted the backrest to the desired angle, using a separate open end wrench, tighten the included jam nut against the backrest bar to prevent the screw from backing out while riding.

5. **Angle** The backrest pad is designed to automatically conform to the angle of the driver's back during riding. No adjustment is necessary.

6. **Removal** Grasp the backrest bar. Pull it firmly up and away from the seat.

7. **Folding** The backrest can be folded forward by pushing the top of the backrest forward. This will assist passenger boarding.

8. **Tension** The tension of the folding process and the angle adjustment can be changed as desired. Tighten or loosen the two horizontal bolts passing through the backrest bar at the hinge and backrest pad attachment points.

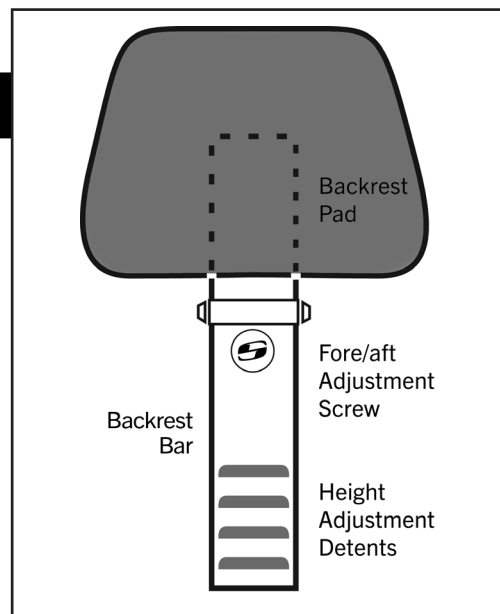
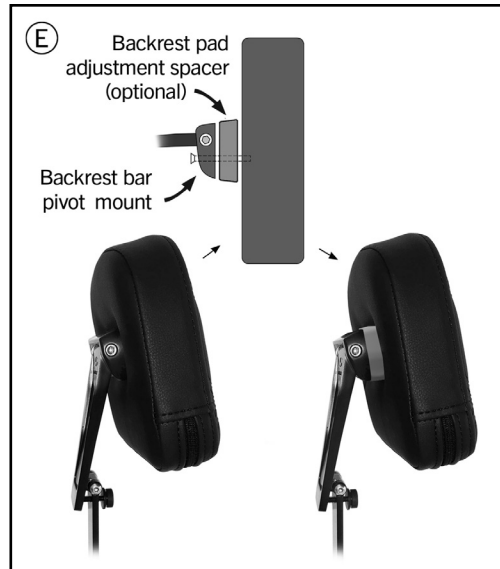

## NOTE:

A REAR TAB FENDER PROTECTOR WASHER IS SUPPLIED with seats that mount with a rear tab. Use this washer between the rear seat tab and your bike's fender to protect the paint. For additional protection, use a Saddlemen Adhesive Fender Washer (PN: 8901) and a Saddlemen part number Protective Tape Kit (PN: 4320-0807) which further protects paint from abrasion damage from a seat, and is also useful when mounting other accessories such as tank bags or saddlebags. NOTE: It is not considered abnormal for your new Saddlemen seat to touch the motorcycle's chassis in certain places (just like your original seat). Due to the natural variance of your vehicle and your new Saddlemen seat, you should always check to see if portions of the seat are touching painted or finished surfaces on your motorcycle. If the test fitting of your seat indicates an area where the seat is touching a sensitive surface, you can protect that area by using the film from the Saddlemen Protective Tape Kit (PN: 4320-0807). This kit can help protect these areas from abrasion damage from a seat. Some seat designs vary from the original seat, so the Protective Tape kit is supplied with these seat models. This will be noted on a decal applied to the seat's pan.

## CAUTION:

It is your responsibility to make sure the seat installation does not create an unsafe or illegal situation. Remember that this seat is a custom accessory. It is your responsibility to check the installation to determine if it will be safe for you to operate the motorcycle and to properly and safely carry a passenger (this includes reinstalling the passenger grab strap or installing a suitable replacement). You must also ensure that the installation does not damage your vehicle in any way. After 50 miles (80 kilometers), recheck the seat's mounting to make sure it is still secure. Inspect all of your accessories and related hardware before and during each ride. An improperly mounted seat can interfere with the vehicle's operation and cause an unsafe riding condition.

IS-11-400243 Tour Step Up (04-2023)



Saddlemen seats are made in the U.S.A. and use the finest materials available.

## ***Congratulations on the purchase of your new Saddlemen motorcycle seat!***

Your seat is warranted against defective material and workmanship for a period of one year from the date of purchase.



### **Caution Handle with Care**

YOUR SADDLEMEN SEAT REQUIRES ALMOST NO MAINTENANCE OTHER THAN PERIODIC CLEANING WITH MILD SOAP AND WATER, AND THE APPLICATION OF A UV INHIBITOR TO PREVENT COLOR FADING CAUSED BY UVA AND UVB SUN EXPOSURE TO THE THREAD. WE RECOMMEND RAY BLOC FABRIC PROTECTOR OR SIMILAR WHICH CAN BE PURCHASED ONLINE OR AT YOUR LOCAL HOME IMPROVEMENT STORE.

THIS SEAT HAS BEEN INSPECTED AND IS FREE OF RIPS, CUTS OR TEARS IN THE COVER. IF THERE IS DAMAGE TO THIS PRODUCT THAT MAY HAVE RESULTED FROM THE FREIGHT COMPANY, SAVE ALL PACKAGING MATERIAL AND PUT IN A CLAIM WITH THAT CARRIER.

ALL REPAIRS AND REPLACEMENTS WILL BE DONE AT THE DISCRETION OF THE MANUFACTURER. ANY MODIFICATIONS TO THE PRODUCT WILL VOID WARRANTY. NO WARRANTY CLAIMS SHALL EXCEED THE PURCHASE PRICE OF THE SEAT.

THIS SADDLEMEN SEAT WAS DESIGNED TO FIT ONTO A STOCK MOTORCYCLE. IF ANY PART OF THE MOTORCYCLE (FRAME, FENDER, GAS TANK, ETC) HAS BEEN ALTERED OR CHANGED, THERE IS NO GUARANTEE OF PROPER FITMENT. SADDLEMEN IS NOT RESPONSIBLE FOR ANY DAMAGE THAT MAY OCCUR BY ATTEMPTING TO INSTALL A NEW SEAT ONTO A MODIFIED, NON-STOCK MOTORCYCLE.

SADDLEMEN WILL NOT BE LIABLE FOR CONSEQUENTIAL OR INCIDENTAL DAMAGES. RETURNED SEATS MUST BE IN LIKE NEW CONDITION.

### **Confirm Proper Fitment**

Always carefully check fitment before the final mounting of your new seat. DO NOT bolt down the seat until you confirm it fits properly. When checking fitment of your Saddlemen seat, place a cloth under the seat then carefully set the seat on the bike and confirm fitment.

WHEN HANDLING THIS PRODUCT, AVOID CONTACT WITH SHARP EDGES OR HARD PARTS. THIS MAY RESULT IN DAMAGE AND VOID WARRANTY.

**WARNING:** Inspect the hardware before and during each ride. Loose mounting hardware can interfere with the vehicle's operation and cause an unsafe riding condition.

## ***Limited Warranty Policy***

**Saddlemen warrants to the original retail purchaser that for a period of one year from the date of retail purchase, they will repair or replace, at their option, any product which is defective in material or workmanship.**

### **What is Covered**

Replacement parts and labor are covered. Return ground transportation charges to Consumer for repaired product are covered. REPAIR OR REPLACEMENT AS PROVIDED IN THE WARRANTY IS YOUR EXCLUSIVE REMEDY.

### **What is Not Covered**

Saddlemen does not warrant any product which is damaged from abuse, lack of maintenance or is not used for its intended purpose. Normal wear and tear are excluded. This Limited Warranty does not cover or apply to any loss or damage to the motorcycle or other items which may have been caused by the defective product and does not apply to personal injury, repair or other incidental costs caused by defective product. Transportation charges to Saddlemen for defective product are not covered. Sales outside of the United States and any other expenses are not covered.

CONSEQUENTIAL DAMAGES, INCIDENTAL DAMAGES, OR INCIDENTAL EXPENSES, INCLUDING DAMAGE TO PROPERTY, ARE NOT COVERED. SOME STATES DO NOT ALLOW THE EXCLUSION OR LIMITATION OF INCIDENTAL OR CONSEQUENTIAL DAMAGES, SO THE ABOVE LIMITATION OR EXCLUSION MAY NOT APPLY TO YOU.

### **Warranty Coverage**

At the option of Saddlemen, your returned product will be repaired to our current design standard or replaced at our cost with either identical product or our most equivalent current product and returned with transportation charges prepaid via regular surface transportation to any location in the continental US.

THIS IS THE ONLY EXPRESS WARRANTY GIVEN WITH RESPECT TO YOUR PRODUCT. ALL OTHER EXPRESS WARRANTIES, GUARANTEES (EXCEPT WRITTEN "SATISFACTION GUARANTEE") OR STATEMENTS REGARDING THE PRODUCT ARE HEREBY DEEMED NULL AND VOID AND OF NO EFFECT.

### **Disclaimer of Other Warranties**

ANY IMPLIED WARRANTY WHETHER OF MERCHANTABILITY, FITNESS FOR A PARTICULAR PURPOSE, OR OTHERWISE ON THIS PRODUCT IS LIMITED TO THE DURATION OF THIS WARRANTY, EXCEPT TO THE EXTENT PROHIBITED BY APPLICABLE LAW. SOME STATES DO NOT ALLOW LIMITATIONS ON HOW LONG AN IMPLIED WARRANTY WILL LAST, SO THE PRECEDING LIMITATION MAY NOT APPLY TO YOU.

### **Implied Warranties**

ANY IMPLIED WARRANTIES, INCLUDING THE IMPLIED WARRANTIES OF MERCHANTABILITY AND FITNESS FOR A PARTICULAR PURPOSE, ARE LIMITED IN DURATION TO ONE YEAR FROM DATE OF RETAIL PURCHASE. SOME STATES DO NOT ALLOW LIMITATIONS ON HOW LONG AN IMPLIED WARRANTY LASTS, SO THE ABOVE LIMITATIONS MAY NOT APPLY TO YOU.

To the extent any provision of this warranty is prohibited by federal, state or municipal law and cannot be preempted, it shall not be applicable.

This warranty gives you specific legal rights, and you may also have other rights which vary from state to state.

IS-11-400243 Tour Step Up (04-2023)