

Instruction 510-0418

09-26-16

Version 1

Copyright © 2016

by S&S® Cycle, Inc.

All rights reserved.

Printed in the U.S.A.

**S&S® Cycle, Inc.**

14025 Cty Hwy G

Viola, Wisconsin 54664

Phone: 608-627-1497 • Fax: 608-627-1488

Technical Service Phone: 608-627-TECH (8324)

Technical Service Email: [sstech@sscycycle.com](mailto:sstech@sscycycle.com)

Website: [www.sscycycle.com](http://www.sscycycle.com)



## Installation Instructions: S&S Oil Line Installation Kit For 2006-'17 Harley-Davidson® Dyna® Models With S&S Crankcases

### DISCLAIMER:

Many S&S parts are designed for high performance, closed course, racing applications and are intended for the very experienced rider only. The installation of S&S parts may void or adversely affect your factory warranty. In addition such installation and use may violate certain federal, state, and local laws, rules and ordinances as well as other laws when used on motor vehicles used on public highways. Always check federal, state, and local laws before modifying your motorcycle. It is the sole and exclusive responsibility of the user to determine the suitability of the product for his or her use, and the user shall assume all legal, personal injury risk and liability and all other obligations, duties, and risks associated therewith.

NOT LEGAL FOR SALE OR USE IN CALIFORNIA ON ANY POLLUTION CONTROLLED MOTOR VEHICLES

### SAFE INSTALLATION AND OPERATION RULES:

Before installing your new S&S part, it is your responsibility to read and follow the installation and maintenance procedures in these instructions and follow the basic rules below for your personal safety.

- Gasoline is extremely flammable and explosive under certain conditions and toxic when breathed. Do not smoke. Perform installation in a well ventilated area away from open flames or sparks.
- If motorcycle has been running, wait until engine and exhaust pipes have cooled down to avoid getting burned before performing any installation steps.
- Before performing any installation steps, disconnect battery to eliminate potential sparks and inadvertent engagement of starter while working on electrical components.
- Read instructions thoroughly and carefully so all procedures are completely understood before performing any installation steps. Contact S&S with any questions you may have if any steps are unclear or any abnormalities occur during installation or operation of motorcycle with an S&S part on it.
- Consult an appropriate service manual for your motorcycle for correct disassembly and reassembly procedures for any parts that need to be removed to facilitate installation.
- Use good judgment when performing installation and operating motorcycle. Good judgment begins with a clear head. Don't let alcohol, drugs or fatigue impair your judgment. Start installation when you are fresh.
- Be sure all federal, state and local laws are obeyed with the installation.
- For optimum performance and safety and to minimize potential damage to carb or other components, use all mounting hardware that is provided and follow all installation instructions.
- Motorcycle exhaust fumes are toxic and poisonous and must not be breathed. Run motorcycle in a well ventilated area where fumes can dissipate.

### IMPORTANT NOTICE:

Statements in this instruction sheet preceded by the following words are of special significance.



**WARNING**

Means there is the possibility of injury to yourself or others.



**CAUTION**

Means there is the possibility of damage to the part or motorcycle.

**NOTE**

*Other information of particular importance has been placed in italic type.*

*S&S recommends you take special notice of these items.*

### WARRANTY:

All S&S parts are guaranteed to the original purchaser to be free of manufacturing defects in materials and workmanship for a period of twelve (12) months from the date of purchase. Merchandise that fails to conform to these conditions will be repaired or replaced at S&S's option if the parts are returned to us by the purchaser within the 12 month warranty period or within 10 days thereafter.

In the event warranty service is required, the original purchaser must call or write S&S immediately with the problem. Some problems can be rectified by a telephone call and need no further course of action.

A part that is suspect of being defective must not be replaced by a Dealer without prior authorization from S&S. If it is deemed necessary for S&S to make an evaluation to determine whether the part was defective, a return authorization number must be obtained from S&S. The parts must be packaged properly so as to not cause further damage and be returned prepaid to S&S with a copy of the original invoice of purchase and a detailed letter outlining the nature of the problem, how the part was used and the circumstances at the time of failure. If after an evaluation has been made by S&S and the part was found to be defective, repair, replacement or refund will be granted.

### ADDITIONAL WARRANTY PROVISIONS:

- (1) S&S shall have no obligation in the event an S&S part is modified by any other person or organization.
- (2) S&S shall have no obligation if an S&S part becomes defective in whole or in part as a result of improper installation, improper maintenance, improper use, abnormal operation, or any other misuse or mistreatment of the S&S part.
- (3) S&S shall not be liable for any consequential or incidental damages resulting from the failure of an S&S part, the breach of any warranties, the failure to deliver, delay in delivery, delivery in non-conforming condition, or for any other breach of contract or duty between S&S and a customer.

*NOTE: S&S Oil Line Installation kits for 2006-'17 Harley-Davidson® Dyna® models are designed specifically to facilitate the installation of Dyna model specific S&S crankcases and engines. This is not a stock replacement oil pan, and will not work with stock Harley-Davidson engines.*

1. Remove the stock engine from the chassis. Refer to the factory service manual for the recommended procedure.
2. Remove the stock oil pan from the transmission, save the stock mounting screws.
3. Remove the starter from the motorcycle.
4. Block the front of the transmission up to allow access to the frame cross-member for modification.
5. Modify frame cross-member
  - a. Remove the wiring harness "fir tree" fastener from the frame cross-member and use a wire tie to fasten the wiring harness to the frame.
  - b. Using the fastener hole in the flat portion of the frame cross-member as a pilot, cut out the majority of the flat area with a 1" hole saw. See **Picture 1**.
  - c. Use a die-grinder to remove most of the remaining flat area and

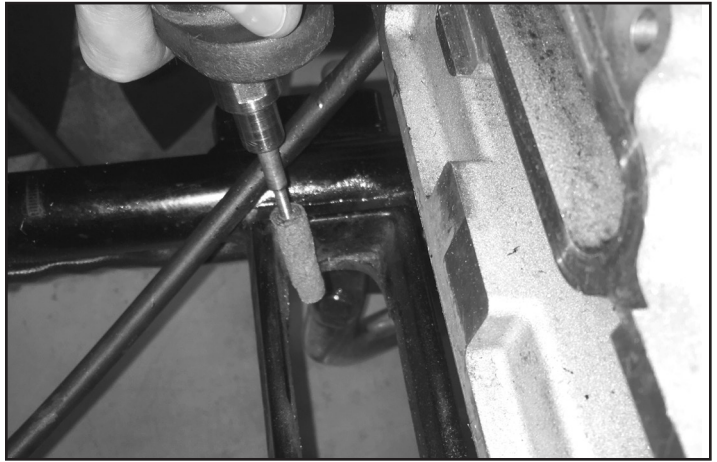

**Picture 3**

- d. Use a sanding roll to smooth the edges of the remaining metal.
    - e. Protect the bare metal with rust resistant paint.
  6. Install the engine, starter, and primary. Refer to the appropriate factory manual or engine instructions for the recommended procedures.
  7. Prepare oil pan for installation.
    - a. Install both drain plugs in the S&S oil pan. See **Pictures 4 & 5**.



**Picture 1**

blend it to the round frame tubes. See **Picture 2**.

- d. Use a sanding roll to smooth the edges of the remaining metal.

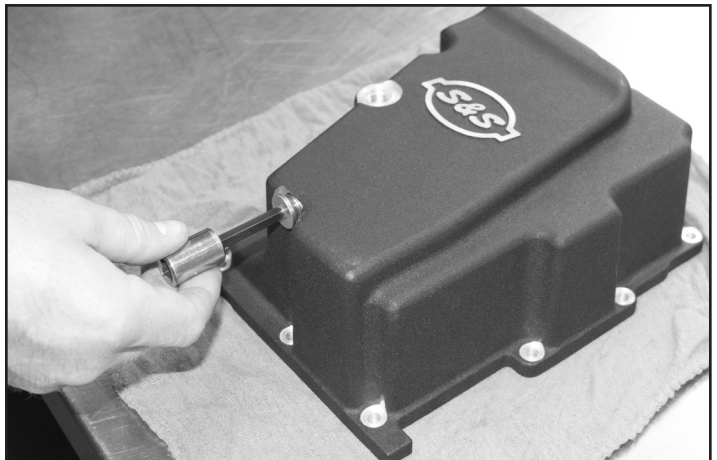

**Picture 4**



**Picture 2**

See **Picture 3**.



**Picture 5**

- b. Install two o-rings and plastic washers on the breather tube as shown in **Picture 6**. Lubricate o-rings with assembly lube.

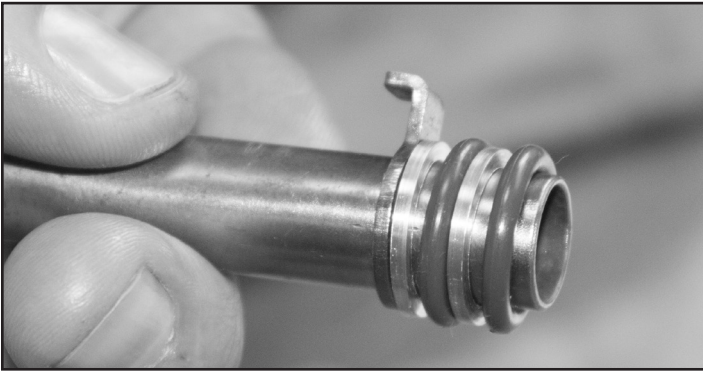

**Picture 6**

- c. Insert the breather tube into the oil pan as shown in **Picture 7**. Push on the o-rings with a flat bladed screw driver to ensure that the o-rings slide smoothly into the breather tube bore, and are not damaged or torn by the tab-lock cut-out in the breather tube bore. .



**Picture 7**

*NOTE: Make sure the breather tube is inserted completely and the bent tab bracket portion of the tube is below the baffle surface of the oil pan as shown in **Picture 8**.*



**Picture 8**

- d. Slip the baffle plate over the breather tube as shown in **Picture 9**.

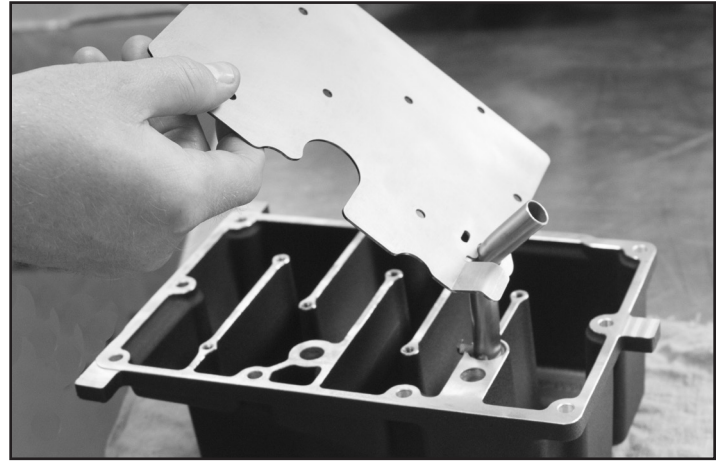

**Picture 9**

- e. Apply red thread locker to the baffle plate screws and fasten the baffle plate to the baffle surface of the oil pan. Tighten the screws to 50 in-lb. See **Picture 10**.

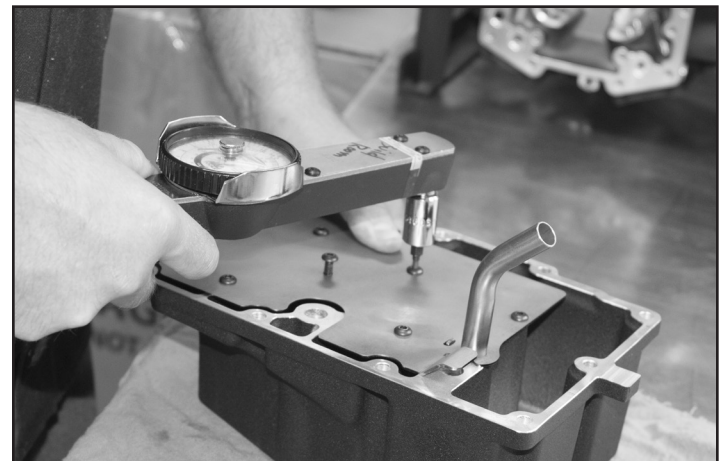

**Picture 10**

- f. Install two o-rings and plastic washers on both ends of each of the three "L" shaped oil lines as shown in **Picture 11**. Lubricate the o-rings with assembly lube. All three "L" shaped oil lines are identical.



**Picture 11**

- g. Install the three oil lines in the oil line bores in the front of the oil pan with the shorter leg toward the oil pan. The longer legs will point up past the gasket surface of the oil pan. See **Picture 12**.

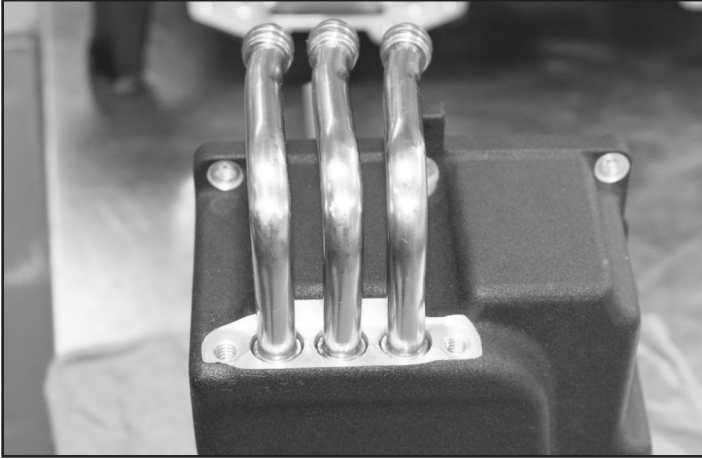

**Picture 12**

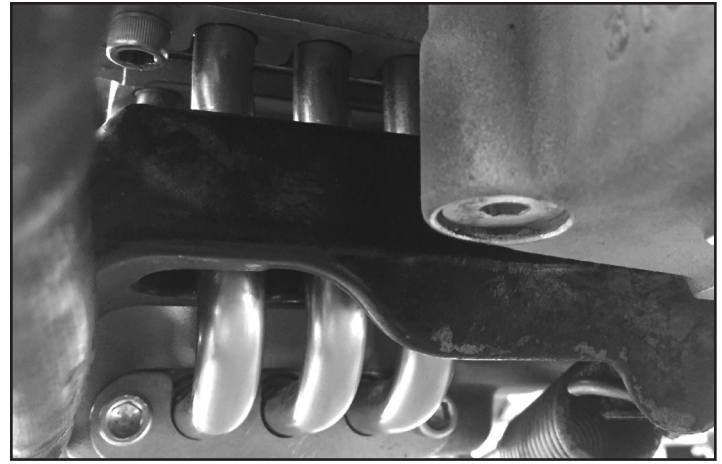

**Picture 14**

- h. Install the oil line retention plate. Apply blue thread locker to the 5/16"-18 X 3/4" screws and fasten the retention plate to the oil pan. Tighten screws to 15-18 ft-lb.
- i. Apply high temp gasket sealer or silicone sparingly to the gasket surface of the oil pan. Install the oil pan gasket to the oil pan, and allow it to set for a few minutes. The object of this is to keep the gasket in place while installing the oil pan.
8. Install the oil pan.
- a. Apply blue thread locker to the stock oil pan mounting bolts and to the oil line retention plate mounting bolts and set aside.
- b. Place the oil pan assembly under the motorcycle. Raise the rear end of the pan, and move it toward the engine until the rear of the pan is inserted between the frame rails where they are farther apart. See **Picture 13**.



**Picture 13**

- e. Start several of the oil pan screws into the transmission, but do not tighten yet.
- f. Ensure the raised bead on the oil line is flush with, or below the retention plate surface of the crankcase.
- g. Install the oil line retention plate on the crankcase. Install the mounting screws and tighten to 15-18 ft-lb.
- h. Install the rest of the oil pan screws and torque to 120 in-lb.
9. Reinstall exhaust pipes and any other components removed during the installation.
10. Fill oil pan with recommended engine oil. Start engine and check for leaks.

- c. Move the oil pan toward the back of the bike, raising the front of the pan. Take care that the breather tube does not hang up on the gasket surface on the front of the transmission.
- d. While raising the oil pan, insert the oil lines into the oil line bores in the S&S crankcase. The oil lines will go through the cross-member of the frame, that was modified in Step 5. See **Picture 14**.

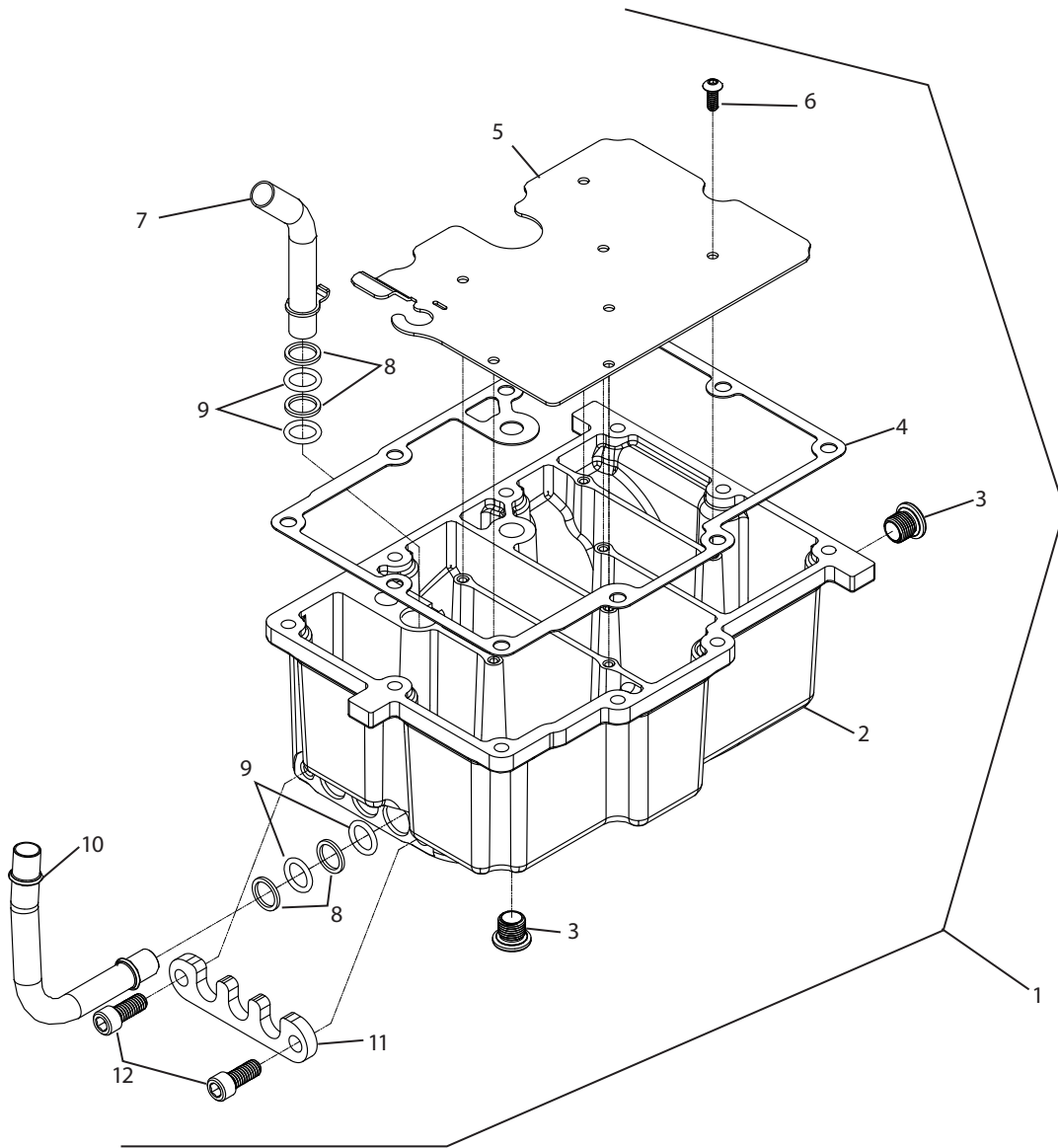

## Replacement Parts

1. Installation Kit, Oil Line, 2006-up Dyna®	
Wblack.....	310-0870
Silver.....	310-0871
2. Pan, Oil, Machined, 2006-up Dyna®	
Wblack.....	310-0863
Silver.....	310-0864
3. Plug, Drain, w/ O-ring, Magnetic, 1/2-20, Zinc.....	50-8335
4. Gasket, Oil Pan, 2006-up Dyna®.....	310-0875
5. Plate, Baffle, .060" Thick, Steel, 2006-up Dyna®.....	310-0874
6. Screw, BHC, 10-24 x 1/2", Black Oxide.....	500-0520
7. Tube, Breather, Bent w/ Tab, Steel, 2006-up Dyna®.....	310-0873
8. Washer, .650" x .505" x .062" Thick, Plastic, PTFE.....	500-0519
9. O-ring, (-112), .487" ID x .693" OD, Viton®.....	500-0518
10. Oil Line, Bent, .500" OD x .035" Wall, 2006-up Dyna®.....	310-0872
11. Clamp, Hold-Down, Oil Line, Polished, 2006-up Dyna®.....	310-0867
12. Screw, SHCS, 5/16-18 x 3/4", Zinc, ASTM A574.....	50-0302-s