

Instruction 510-0481
09-10-18

Version 1

© 2018
by S&S® Cycle, Inc.
All rights reserved.
Printed in the U.S.A.

S&S® Cycle, Inc.

14025 Cty Hwy G

Viola, Wisconsin 54664

Phone: 608-627-1497 • Fax: 608-627-1488

Technical Service Phone: 608-627-TECH (8324)

Technical Service Email: sstech@sscycle.com

Website: www.sscycle.com



Installation Instructions: S&S 4.250" Bore Cylinder & Piston Kits for M8 2017-'18

DISCLAIMER:

Many S&S parts are designed for high performance, closed course, racing applications and are intended for the very experienced rider only. The installation of S&S parts may void or adversely affect your factory warranty. In addition such installation and use may violate certain federal, state, and local laws, rules and ordinances as well as other laws when used on motor vehicles used on public highways. Always check federal, state, and local laws before modifying your motorcycle. It is the sole and exclusive responsibility of the user to determine the suitability of the product for his or her use, and the user shall assume all legal, personal injury risk and liability and all other obligations, duties, and risks associated therewith.

NOT LEGAL FOR SALE OR USE IN CALIFORNIA ON ANY POLLUTION CONTROLLED MOTOR VEHICLE.

Not legal for sale or use on any EPA pollution controlled motor vehicle.

IMPORTANT NOTICE:

Statements in this instruction sheet preceded by the following words are of special significance.



WARNING

Means there is the possibility of injury to yourself or others.



CAUTION

Means there is the possibility of damage to the part or motorcycle.

NOTE

Other information of particular importance has been placed in italic type.

S&S recommends you take special notice of these items.

SAFE INSTALLATION AND OPERATION RULES:

Before installing your new S&S part, it is your responsibility to read and follow the installation and maintenance procedures in these instructions and follow the basic rules below for your personal safety.

- Gasoline is extremely flammable and explosive under certain conditions and toxic when breathed. Do not smoke. Perform installation in a well ventilated area away from open flames or sparks.
- If motorcycle has been running, wait until engine and exhaust pipes have cooled down to avoid getting burned before performing any installation steps.
- Before performing any installation steps, disconnect battery to eliminate potential sparks and inadvertent engagement of starter while working on electrical components.
- Read instructions thoroughly and carefully so all procedures are completely understood before performing any installation steps. Contact S&S with any questions you may have if any steps are unclear or any abnormalities occur during installation or operation of motorcycle with an S&S part on it.
- Consult an appropriate service manual for your motorcycle for correct disassembly and reassembly procedures for any parts that need to be removed to facilitate installation.
- Use good judgment when performing installation and operating motorcycle. Good judgment begins with a clear head. Don't let alcohol, drugs or fatigue impair your judgment. Start installation when you are fresh.
- Be sure all federal, state and local laws are obeyed with the installation.
- For optimum performance and safety and to minimize potential damage to carb or other components, use all mounting hardware that is provided and follow all installation instructions.
- Motorcycle exhaust fumes are toxic and poisonous and must not be breathed. Run motorcycle in a well ventilated area where fumes can dissipate.

WARRANTY:

All S&S parts are guaranteed to the original purchaser to be free of manufacturing defects in materials and workmanship for a period of twelve (12) months from the date of purchase. Merchandise that fails to conform to these conditions will be repaired or replaced at S&S's option if the parts are returned to us by the purchaser within the 12 month warranty period or within 10 days thereafter.

In the event warranty service is required, the original purchaser must call or write S&S immediately with the problem. Some problems can be rectified by a telephone call and need no further course of action.

A part that is suspect of being defective must not be replaced by a Dealer without prior authorization from S&S. If it is deemed necessary for S&S to make an evaluation to determine whether the part was defective, a return authorization number must be obtained from S&S. The parts must be packaged properly so as to not cause further damage and be returned prepaid to S&S with a copy of the original invoice of purchase and a detailed letter outlining the nature of the problem, how the part was used and the circumstances at the time of failure. If after an evaluation has been made by S&S and the part was found to be defective, repair, replacement or refund will be granted.

ADDITIONAL WARRANTY PROVISIONS:

- (1) S&S shall have no obligation in the event an S&S part is modified by any other person or organization.
- (2) S&S shall have no obligation if an S&S part becomes defective in whole or in part as a result of improper installation, improper maintenance, improper use, abnormal operation, or any other misuse or mistreatment of the S&S part.
- (3) S&S shall not be liable for any consequential or incidental damages resulting from the failure of an S&S part, the breach of any warranties, the failure to deliver, delay in delivery, delivery in non-conforming condition, or for any other breach of contract or duty between S&S and a customer.

Piston Kit Contents

- (2) 4.250" pistons (front and rear pistons are the same)
- (2) 0.927" piston pins
- (4) Piston pin clips
- (2) Ring packs which include the top, second, oil rail, and expander rings

Piston and Cylinder Kit Contents

- (1) 4.250" Piston Kit
- (2) 4.250" Bore Cylinders
- (2) MLS (Multi Layer Steel) head gaskets, 0.030" thick
- (2) Cylinder Base Gaskets
- (4) Cylinder dowels
- (2) Exhaust gaskets
- (2) Expansion plugs
- (1) Expansion plug tool

General Information

- Thoroughly read and understand all the instructions before starting installation.
- S&S 4.250" big bore kits for 4.375" stroke engines contain pistons with 1.143" deck height and -4.3 cc dish volume for an 11:1 CR with stock cylinder head combustion chamber volume.
- S&S 4.250" big bore kits for 4.500" stroke engines contain pistons with 1.0805" deck height and -7.2 cc dish volume for an 11:1 CR with stock cylinder head combustion chamber volume.
- Pistons are the same for the front and rear cylinders and can be used with either cylinder.

Special Tool Requirements

- Harley-Davidson® service manual for the specific model you are working on
- Piston ring compressor
- Piston ring expander
- Piston ring end gap filing tool
- Feeler gauges
- Torque wrench
- 5/32" Flat End Punch
- (2) 5/16-18 x 2-1/2" bolts

Stock Harley-Davidson® Parts

Requirements

- (8) Harley-Davidson® M8 Head Bolts part # 10200303

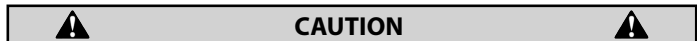

Failure to follow instructions and perform required clearancing, installation and/or break-in procedures may result in damage to pistons and or other engine components not covered under warranty. The proper break-in procedure is in Section 8 of these instructions.

DISASSEMBLY AND INSPECTION

1. Refer to the Harley-Davidson® manual for your specific motorcycle for the correct disassembly procedure.
2. The engine should be disassembled to the short block i.e. induction system, exhaust system, cylinder heads, cylinders, and pistons should be removed.
3. Check cylinder studs to make sure they are fully seated against the case.

INSTALLATION OF EXPANSION PLUGS IN OIL COOLED HEADS

NOTES

- **Important!** Installation of the expansion plugs only applies to oil cooled heads. If you have liquid cooled heads skip to page 4 and disregard the expansion plugs and installation tool that will not be needed.
- **Important!** Installation of the expansion plugs is required for oil cooled heads. Failure to install the plugs will cause an oil leak. Both the front and rear head must be plugged.
- If you are unsure which heads you have please **see Picture 1** for identification. Oil cooled heads will have 1 hole in the head gasket area. Liquid cooled heads will have 2 holes in the head gasket area.



The pistons must be oriented so that the FWD arrow points towards the front of the engine and the dot is towards the cam side of the engine..

- The pistons are machined during manufacturing to provide the correct running clearance when cylinders are bored to nominal size of 4.250". In other words the clearance is built into the piston diameter. Piston to cylinder clearance is 0.003"-0.0035" prior to skirt coating. Piston skirt coating is approximately 30 micron. Any cylinder measurements must be taken with the cylinder in torque plates with bolts tightened at correct torque value to simulate conditions in an assembled engine.
- In all cases it is the engine builder's responsibility to confirm proper clearances when assembling an engine. This is especially critical with performance components such as larger valve, high performance heads and high lift camshafts.
- In addition to clearances mentioned, 0.060" valve to piston clearance must be confirmed.

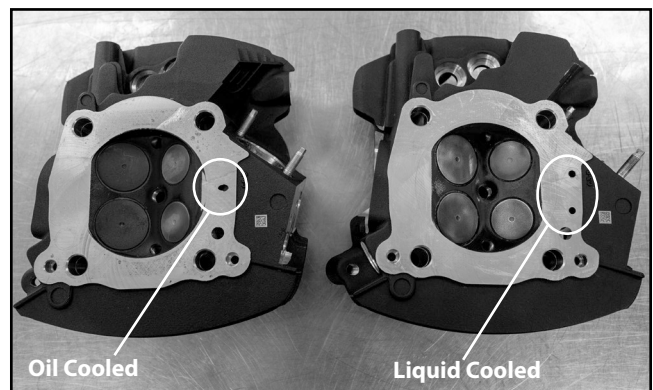

Picture 1

1. Securing Cylinder Head For Plug Installation

- a. Install two 5/16-18 x 2-1/2" bolts into the drive side rocker arm bosses. **See Picture 2 .**

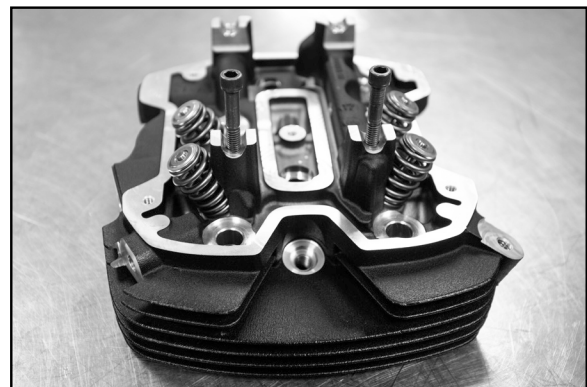

Picture 2

- b. Mount the cylinder head in a bench vise by clamping on the bolts. Be careful not to clamp on the cylinder head or damage will occur. **See Picture 3.**



Picture 3

- c. Confirm the plug is completely inside the hole and resting against the installation tool. Use a hammer and a 5/32" flat end punch to tap the expansion plug ball until the ball is even with the top of the plug casing. **See Picture 6.**



Picture 6

2. Installing Expansion Plugs

- a. Install provided expansion plug installation tool into the oil passage closest to the head gasket surface until it stops. **See Picture 4.**

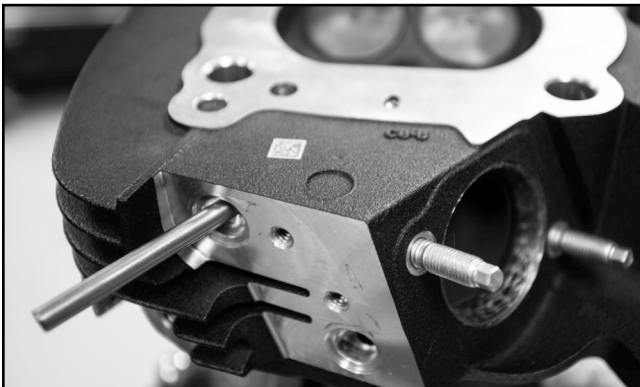

Picture 4

- d. Confirm the top of the expansion ball is flat with the top of the plug casing. It is normal for the top of the ball and casing to deform slightly. **See Picture 7.**

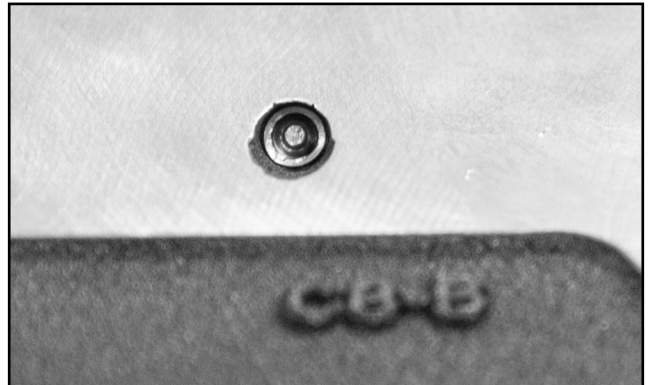

Picture 7

- b. Install expansion plug with the ball side facing up. Use a flat end 5/32" punch to slide the plug in until it stops against the installation tool. **See Picture 5.**



Picture 5

- e. Use a pair of channel locks to spin and pull on the installation tool for removal. **See Picture 8.**



Picture 8

- f. Repeat securing of the cylinder head and installation of the expansion plug for the other head.

INSTALLATION AND REASSEMBLY

1. Setting Ring End Gaps

NOTES

- **Important!** The gap of the second ring should be larger than the top ring; this will help keep the top ring seated for improved performance.
- Each ring should be fitted to the particular cylinder in which they will be installed.
- Oil rails can be installed without adjusting the end gap. The minimum gap should be 0.010"
- Never alter the end gap of the oil expander ring.
- Always install the ends of the expander facing up as shown in **Figure 1 and Picture 11 (next column)**.

- Thoroughly wash cylinders with hot soapy water, then wash with brake cleaner and wipe with a clean white towel. Repeat until towel does not show evidence of debris and apply a light coat of oil immediately.
- Check the ring end gap by placing the ring into the cylinder. Use a piston or caliper to ensure that the ring is placed squarely in the bore. **See Picture 9.**

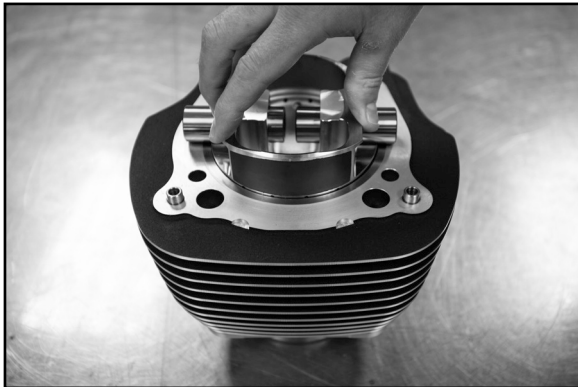

Picture 9

- Measure the ring end gap with a feeler gauge. **See Picture 10.**



Picture 10

- See Table 1** for proper end gap measurement. If adjustment to the gap must be made, use a proper ring end gap filing tool.

Ring End Gap		
Top Ring	Second Ring	Oil Ring
.020" - .024"	.024" - .028"	.010" Minimum Do not file
Note: For racing applications adjust ring end gap to the high end of the specification		

Table 1

- Always file from the ring face towards the inside diameter to avoid damaging the face coating.
- Remove material from only one end of the ring.
- Ensure that ring end gaps are square.
- Remove sharp edges and burrs.
- Recheck gap measurement and adjust as necessary.
- Repeat procedure with the other rings.

2. Piston Ring Installation

- Order of installation
 - Oil ring expander (ends must face up as shown in **Figure 1**).

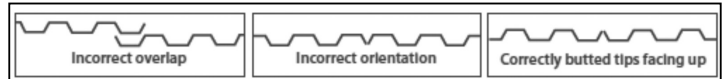
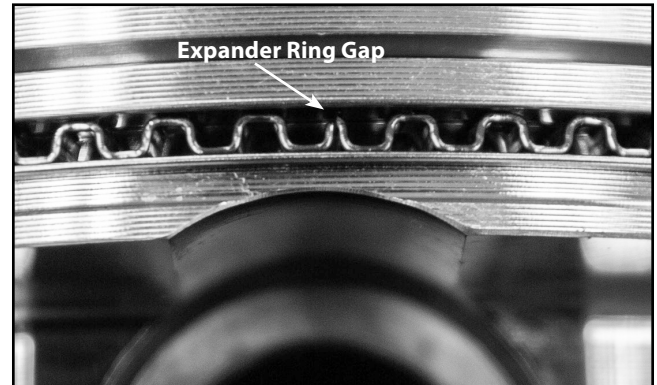

Figure 1

- Oil ring rails
- 2nd ring. Black finish with Napier cut. Dot faces up.
- Top ring. Shiny finish. Dot and MTOP faces up.

- Install the oil ring expander in the bottom groove of the piston. Make sure the ends of the expander ring are butted together and not overlapping. **See Figure 1.** If the tips are overlapped, excessive oil consumption will occur. Orient the expander end gap such that it can be viewed as it enters the cylinder. **See Picture 12.**



Picture 11

- Install oil rails. The oil rails are the thinnest of all the rings. Either side can be placed up. Install the rails into the groove by hand. Install one rail above the expander, and one below. Orient the gaps according to **Picture 12.**

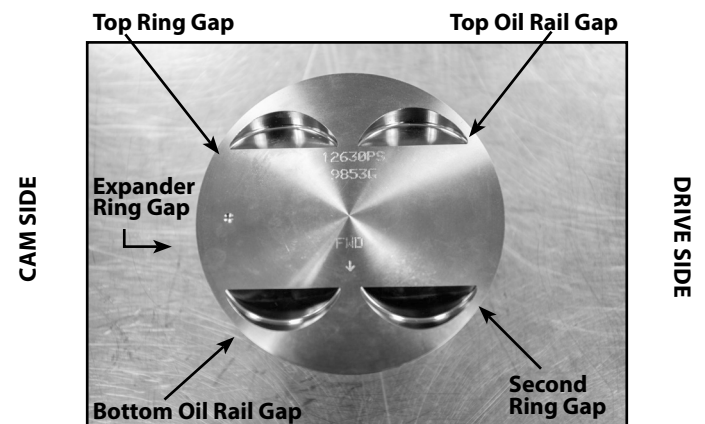

Picture 12

- d. Install the 2nd ring with the dot facing up. **See Picture 13.** The Napier cut will face down. Use an expander to install the ring to the 2nd groove in the piston. Orient the gap according to **Picture 12.**

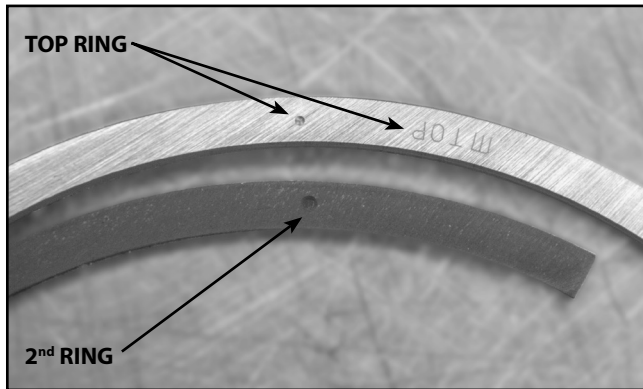

Picture 13

3. Piston Installation

NOTES

- *Pistons are identical and can be installed in either cylinder.*
- *Check piston pin to connecting rod clearance. Clearance should be between 0.0007" and 0.002"*



The pistons must be oriented so that the FWD arrow points towards the front of the engine and the dot is towards the cam side of the engine.

- a. Place rubber tubing over the cylinder studs to prevent damage to the pistons and rings during assembly.
- b. Place a clean sheet of plastic over the crankcase openings to prevent anything from dropping into the crankcase.
- c. Install one of the piston pin clips into each of the pistons.
- d. Lightly oil the piston pin, piston pin bore and upper connecting rod bushing with assembly lube.
- e. Hold the piston over the connecting rod with the piston facing the correct direction and the piston pin bore and upper bushing bores lined up.
- f. Install the piston pin through the piston pin bore and through the connecting rod bushing until the pin contacts the clip.
- g. Install the other piston clip. Ensure that both clips are fully seated.
- h. Repeat procedure for the other piston.

4. Cylinder Installation

- a. Bring the front cylinder to TDC.
- b. Apply a light coating of oil to the piston and rings.
- c. Install base gasket with so you can read the UP and the cut out edge faces the lifter cover.
- d. Verify that the ring gaps are orientated correctly, refer to **Picture 12.**
- e. Remove the rubber tubing from the cylinder studs.

- f. Compress ring pack by using a suitable ring compressor. If possible, position the ring compressor so that you can see the oil expander gap during installation. **See Picture 11.**
- g. Install cylinder on piston, making sure not to overlap oil ring expander.
- h. Remove ring compressor.
- i. Remove plastic sheeting covering crankcase.
- j. Slide the cylinder down until it seats against the crankcase.
- k. Rotate the engine until the rear cylinder is at TDC.
- l. Repeat procedure for the rear cylinder.

5. Cylinder Head Installation



New Harley- Davidson® head bolts part # 10200303 must be used. The following torque sequence must be followed. Failure to do so will result in engine failure not covered under warranty.

- a. Check surfaces for flatness and imperfections, an excessively rough finish may cause gasket failure.
- b. Install cylinder dowels.
- c. Clean all threads and lubricate with clean oil. Lubricate the underside flange of the head bolts with clean oil .
- d. Locate the embossed fire ring on center layer of the multilayer head gasket. Install the head gasket with this bump facing the cylinder. **See Picture 14.**

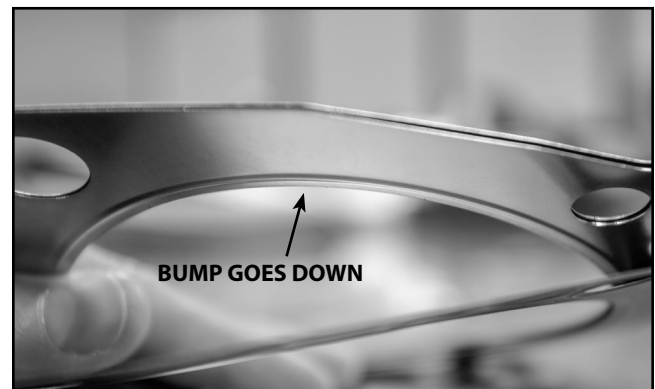

Picture 14

- e. Once the gasket is in place, make sure that it fits the bore. The gasket should not hang into the bore or combustion chamber area.
- f. If using cylinder heads other than stock, check the brass rivets of the MLS gaskets to ensure the rivets do not interfere with the sealing surface in any way.

CAUTION

New Harley- Davidson® head bolts part # 10200303 must be used. The following torque sequence must be followed. Failure to do so will result in engine failure not covered under warranty.

- g. Tighten the head bolts according to the following procedure, start with the front head then the rear head.
 - i. Tighten each bolt finger tight using the sequence in **Figure 2**.
 - ii. Tighten each bolt to 10 ft-lbs using the same sequence.
 - iii. Tighten each bolt to 20 ft-lbs using the same sequence.
 - iv. Tighten each bolt to 30 ft-lbs using the same sequence.
 - v. Fully loosen each bolt 1/4 turn at a time in the reverse sequence.
 - vi. Tighten each bolt finger tight using the sequence in **Figure 2**.
 - vii. Tighten each bolt to 10 ft-lbs using the same sequence.
 - viii. Tighten each bolt to 20 ft-lbs using the same sequence.
 - ix. Tighten each bolt to 25 ft-lbs using the same sequence.
 - x. Tighten each bolt to 30 ft-lbs using the same sequence.
 - xi. Tighten each bolt to 35 ft-lbs using the same sequence.
 - xii. Final tighten each bolt to 45 ft-lbs using the same sequence.
 - xiii. Wait 15 minutes then recheck each bolt at 45 ft-lbs using the same sequence.

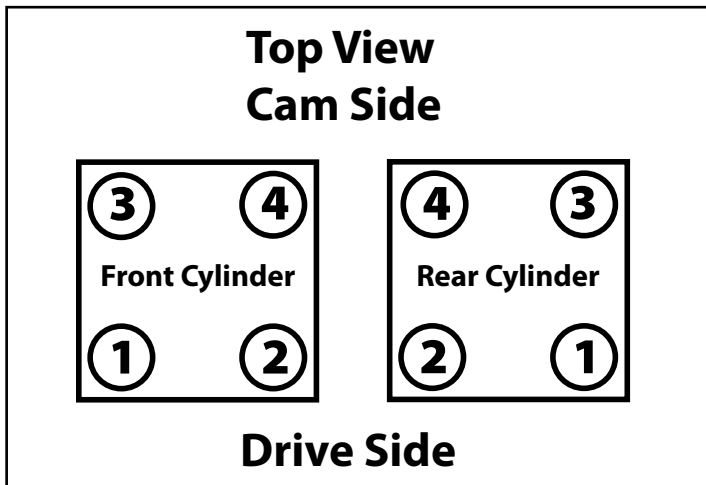

Figure 2

6. Final Assembly

Assemble the remaining items according to the Harley-Davidson® service manual specific for your motorcycle.

7. Tuning

S&S big bore kits increase the displacement and compression ratio of your engine. The fuel and ignition systems must be calibrated for these changes before the engine is driven and break-in is attempted. Fuel injected engines must be tuned using an aftermarket tuner such as the DynoJet® Power Vision® tuner.

8. Break-in Procedure

NOTES:

- S&S engines and parts are designed for high performance and are not as tolerant of inadequate break-in. Correct break-in will assure longer engine life and will prevent unnecessary engine damage. Engine

damage caused by improper break-in is not covered under the S&S Warranty.

- Proper engine tuning will be required in order for your engine to run correctly and to prevent damage. It is recommended to start by adding 10% fuel across the map if you do not have a tune file for the set-up you are running.
 - a. Initial start up. Run the engine approximately one minute at 1250-1750rpm. DO NOT crack the throttle or subject to any loads during this period as head gaskets are susceptible to failure at this time. During this time, check to see that oil pressure is normal, oil is returning to the oil tank and no leaks exist.
 - b. Shut off engine and inspect for leaks. Allow engine to cool to the touch.
 - c. Start up engine again and allow the engine to warm up for 3 to 4 minutes. Again, do not crack the throttle or subject the engine to any type of load. Shut down the engine and allow to cool. Repeat this procedure at least 3 more times.
 - d. After the engine has cooled to room temperature, you are ready to start the 500 mile engine break-in process.
 - e. The first 50 miles are the most critical for new rings and piston break-in. Engine damage is most likely to occur during this period. Keep heat down by not exceeding 2500rpm. Avoid lugging the engine, riding in hot weather or in traffic. Vary the engine speed. We recommend changing the oil after the first 50 miles.
 - f. The next 500 miles should be spent running no faster than 3500rpm or 60mph. Avoid running continuous steady speeds, and do not lug the engine, Vary the rpm. We recommend changing the oil again at 500 miles.
 - g. For the balance of the first 1000 miles the engine can be run in a normal but conservative manner. You can be more liberal with the rpm range and the motorcycle can be operated at normal highway speeds. Avoid overheating or putting any hard strain on the engine; no drag racing, dyno runs, excessive speed, trailer towing or side car operation.
 - h. After 1000 miles, change the engine oil. Now the motorcycle can be operated normally.

OIL RECOMMENDATIONS

S&S® Cycle recommends the use of S&S 20W-50 synthetic based V-Twin Motor Oil.

Break-in can be performed with either synthetic or petroleum based oil.

Regardless of what type of oil you select, be sure to only use oil specifically designated for use in an air cooled motorcycle engine. If you prefer not to use a multi-viscosity oil, utilize the viscosity suggested for the temperature you will be operating your motorcycle in.

Instruction 510-0582

07-02-18

Version 2

© 2018

by S&S® Cycle, Inc.

All rights reserved.

Printed in the U.S.A.

S&S® Cycle, Inc.

14025 Cty Hwy G

Viola, Wisconsin 54664

Phone: 608-627-1497 • Fax: 608-627-1488

Technical Service Phone: 608-627-TECH (8324)

Technical Service Email: sstech@sscycycle.com

Website: www.sscycycle.com



Installation Instructions: Cam Support Plate for 2017-up M8 Models

DISCLAIMER:

Many S&S parts are designed for high performance, closed course, racing applications and are intended for the very experienced rider only. The installation of S&S parts may void or adversely affect your factory warranty. In addition such installation and use may violate certain federal, state, and local laws, rules and ordinances as well as other laws when used on motor vehicles used on public highways. Always check federal, state, and local laws before modifying your motorcycle. It is the sole and exclusive responsibility of the user to determine the suitability of the product for his or her use, and the user shall assume all legal, personal injury risk and liability and all other obligations, duties, and risks associated therewith.

SAFE INSTALLATION AND OPERATION RULES:

Before installing your new S&S part, it is your responsibility to read and follow the installation and maintenance procedures in these instructions and follow the basic rules below for your personal safety.

- Gasoline is extremely flammable and explosive under certain conditions and toxic when breathed. Do not smoke. Perform installation in a well ventilated area away from open flames or sparks.
- If motorcycle has been running, wait until engine and exhaust pipes have cooled down to avoid getting burned before performing any installation steps.
- Before performing any installation steps, disconnect battery to eliminate potential sparks and inadvertent engagement of starter while working on electrical components.
- Read instructions thoroughly and carefully so all procedures are completely understood before performing any installation steps. Contact S&S with any questions you may have if any steps are unclear or any abnormalities occur during installation or operation of motorcycle with an S&S part on it.
- Consult an appropriate service manual for your motorcycle for correct disassembly and reassembly procedures for any parts that need to be removed to facilitate installation.
- Use good judgment when performing installation and operating motorcycle. Good judgment begins with a clear head. Don't let alcohol, drugs or fatigue impair your judgment. Start installation when you are fresh.
- Be sure all federal, state and local laws are obeyed with the installation.
- For optimum performance and safety and to minimize potential damage to carb or other components, use all mounting hardware that is provided and follow all installation instructions.
- Motorcycle exhaust fumes are toxic and poisonous and must not be breathed. Run motorcycle in a well ventilated area where fumes can dissipate.

IMPORTANT NOTICE:

Statements in this instruction sheet preceded by the following words are of special significance.



WARNING

Means there is the possibility of injury to yourself or others.



CAUTION

Means there is the possibility of damage to the part or motorcycle.

NOTE

Other information of particular importance has been placed in italic type.

S&S recommends you take special notice of these items.

WARRANTY:

All S&S parts are guaranteed to the original purchaser to be free of manufacturing defects in materials and workmanship for a period of twelve (12) months from the date of purchase. Merchandise that fails to conform to these conditions will be repaired or replaced at S&S's option if the parts are returned to us by the purchaser within the 12 month warranty period or within 10 days thereafter.

In the event warranty service is required, the original purchaser must call or write S&S immediately with the problem. Some problems can be rectified by a telephone call and need no further course of action.

A part that is suspect of being defective must not be replaced by a Dealer without prior authorization from S&S. If it is deemed necessary for S&S to make an evaluation to determine whether the part was defective, a return authorization number must be obtained from S&S. The parts must be packaged properly so as to not cause further damage and be returned prepaid to S&S with a copy of the original invoice of purchase and a detailed letter outlining the nature of the problem, how the part was used and the circumstances at the time of failure. If after an evaluation has been made by S&S and the part was found to be defective, repair, replacement or refund will be granted.

ADDITIONAL WARRANTY PROVISIONS:

- (1) S&S shall have no obligation in the event an S&S part is modified by any other person or organization.
- (2) S&S shall have no obligation if an S&S part becomes defective in whole or in part as a result of improper installation, improper maintenance, improper use, abnormal operation, or any other misuse or mistreatment of the S&S part.
- (3) S&S shall not be liable for any consequential or incidental damages resulting from the failure of an S&S part, the breach of any warranties, the failure to deliver, delay in delivery, delivery in non-conforming condition, or for any other breach of contract or duty between S&S and a customer.

NOTES:

- The S&S M8 cam support plate is machined from high strength billet aluminum. This material and manufacturing method provide strength and dimensional stability over aluminum castings. In addition, billet aluminum does not have voids, inclusions and other structural defects associated with aluminum castings.
- Variations in color of the anodized finish is not considered a defect. Despite the variations in color, the ability of the anodized coating to protect the part is unchanged. You may install these products with confidence, knowing that they will function as they are intended.
- Possible failure may result if thread locking compound is not applied to the cam drive sprocket flange bolts. Always prepare threads according to the instructions on the container.
- All reference to Harley-Davidson® part numbers is for identification purposes only. In no way is it implied that any S&S Cycle products are original equipment parts or that they are equivalent to corresponding Harley-Davidson® part numbers.
- Installation of the S&S Cycle cam support plate requires the use of special tools and repair manuals for the model of bike you will be working on. Attempting the installation without the proper tools and manuals will be difficult. Damage can result which will not be covered under warranty.

SPECIAL TOOLS REQUIRED (only needed if inner cam bearing will be replaced)

- Camshaft Needle Bearing Remover/Installer, HD® Part Number: 42325-4
- Crankshaft/Camshaft Sprocket Locking Tool, HD Part Number 42314

Pre-Cautions:

- Clean and flush the oil pan and oil lines to prevent foreign material from being sucked through the oil pump and through the new cam support plate. The oil filter should also be changed when installation is complete.
- **NOTE:** If debris is suspected in the oil pan, it is highly recommended to remove the oil pan in order to thoroughly clean it out.

Installation

1. Unpackaged the cam support plate kit and verify the all the threaded plugs have been installed. Confirm that the kit contains a new o-ring kit and hydraulic tensioner block off plate kit.
2. Prepare the cam support plate for assembly by cleaning the plate with soap and water or parts cleaner. Be sure to thoroughly dry the internal passages.
3. Before starting work on the motorcycle, disconnect the negative terminal of the battery to eliminate the potential for sparks and inadvertent engagement of the starter while working on the motorcycle.
4. Refer to the HD® service manual for the model of bike you will be working on for proper removal of all components. Save the original fasteners to be reused when the the S&S cam support plate is installed.
5. Remove the cam support plate and oil pump from the engine according to the HD® service manual and measure flywheel pinion shaft run out. Refer to the manual for proper procedure. S&S recommends no more than 0.005" of total indicated runout on the pinion shaft while checked in the cases.
6. If you intend to reuse the existing oil pump, it must be thoroughly cleaned and inspected to ensure that it is serviceable. Refer to the manufacturer service wear limits for the gears and pump body bores. If the areas under the pump gears are scored this will adversely affect the ability of the pump to supply and/or return oil.

7. Inspect the inner cam bearing, now is the time to replace this bearing while the engine is apart. It is highly recommended to replace the bearing with a full complement bearing, S&S Cycle pn 31-4199-S. Refer to the service manual for proper procedure to replace this bearing.

NOTE: Use as much of the provided assembly lube as possible on all of the oil pump rotors during assembly. This will aid in priming the oil pump upon start up.

8. Install a new o-ring on the flywheel cavity suction side of the oil pump and re-install the pump into the cam chest. Use a straight edge to confirm that the outer face of the oil pump is recessed slightly from the cam plate mounting surface. **(See Picture 1).** This is done to ensure that there will be no binding in the oil pump when it is tightened to the cam plate.



Picture 1

9. Install a new o-ring into the oil supply port of the engine case. **See Picture 2.**

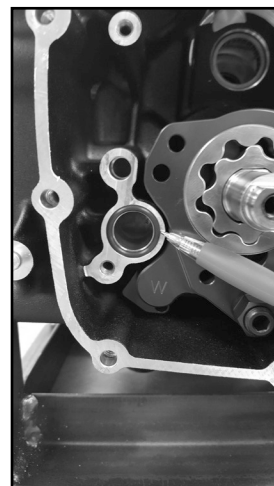

Picture 2

10. Apply assembly lube to the rollers of the inner cam bearing and to the cam bearing surface and lobes of the camshaft. Insert the camshaft into the inner cam bearing.
11. Apply assembly lube to the outer cam bearing surface of the camshaft and to the pinion shaft.
12. Apply assembly lube to the wear plate and place on to the back of the cam support plate. The assembly lube will keep the wear plate from falling off during assembly.
13. Install the cam support plate onto the pinion shaft and camshaft. Make sure the support plate fully contacts the mounting surfaces of the engine case and the dowel is engaged into the mounting hole.

NOTE: The oil supply passage o-ring will hold the plate slightly off the mounting surface until the support plates screws are fully tightened.

14. Turn the crankshaft so that the flat on the pinion shaft is facing straight up (12 o'clock position).
15. Apply a small amount of blue Loctite® to the cam support screws and the new oil pump screws. Make sure the flat washers are installed on the oil pump screws.
16. **Steps 17 thru 23 are critical to proper final assembly.**
17. Make sure the flat on the pinion shaft is facing straight up. **See Picture 3** for correct orientation of pinion shaft.
18. Loosely install all cam support plate and oil pump screws but do not apply any torque.



Picture 3: Cam Support Plate Screws (3-8) and Oil Pump Screws (1, 2, 9, 10)

19. Snug the oil pump screws 1, 2, 9 and 10 but do not torque.
20. Snug the cam support plate screws 3, 4, 5, 6, 7 and 8 but do not torque.
21. Torque screws 3, 4, 5, 6, 7 and 8 in order to 90-120 in*lbs. **See picture 3a.**



Picture 3a: Cam Plate Screws-Torque According to Step 21

22. Rotate the crankshaft two complete revolutions with the flat on the pinion shaft facing straight up (12 o'clock position) when done.
23. Torque the oil pump screws 1, 2, 9 and 10 in that order to 90-120 in*lbs.



Picture 3b: Oil Pump Screws-Torque According to Step 23

24. Rotate the crankshaft to make sure binding does not occur in the oil pump. If binding occurs, loosen the oil pump and cam support plate screws and go through the installation procedure starting at step 17.
25. Recheck the torque on all 10 fasteners in order 1 through 10.

26. Install the cam drive components (chain or gear) according to the manufacturer's installation procedures.
27. Apply blue thread locker to the cam cover screws, install the cam cover, gasket and screws. Tighten the cam cover screws to 120 in-lbs in the sequence shown **(See Picture 4)**.

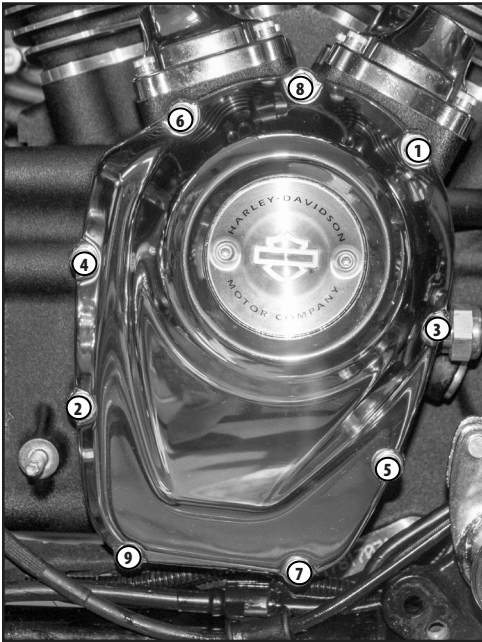

Picture 4

28. Reinstall the pushrods according to the manufacturer's installation procedure.
29. Reinstall exhaust system and right side floor board or foot peg.

Cam Support Plate Replacement Parts

- | | |
|---|----------|
| 1. Cam support plate | N/A |
| 2. Wear plate | 310-0949 |
| 3. 1/8" pipe plug, 10 pack..... | 50-1015 |
| 4. 1/4" pipe plug, 5 pack..... | 500-0969 |
| 5. M8 cam support plate oil supply plug kit | 500-0966 |
| 6. Hydraulic tensioner block off plate kit (not pictured) | 310-0962 |
| 7. O-ring kit (not pictured) | 500-0850 |
| 8. Assembly lube (not pictured)..... | 51-9002 |
| 9. Loctite #243 Blue .5ml (not pictured)..... | 51-9003 |
| 10. Loctite #262 Red .5ml (not pictured)..... | 51-9004 |

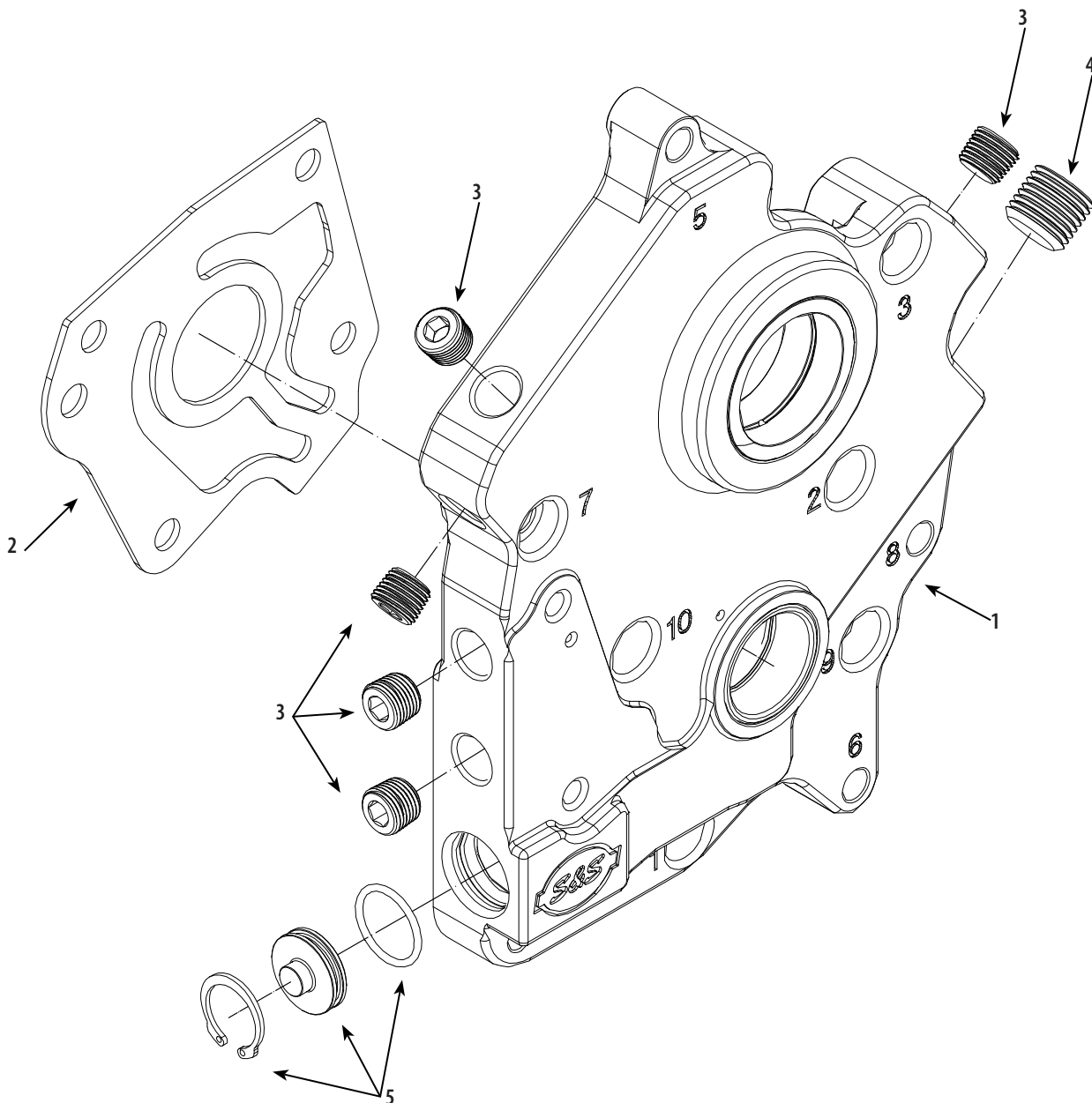

Instruction 510-0467

03-28-2017

Version 1

Copyright © 2017

by S&S® Cycle, Inc.

All rights reserved.

Printed in the U.S.A.

S&S® Cycle, Inc.

14025 Cty Hwy G

Viola, Wisconsin 54664

Phone: 608-627-1497 • Fax: 608-627-1488

Technical Service Phone: 608-627-TECH (8324)

Technical Service Email: sstech@sscycle.com

Website: www.sscycle.com



Installation Instructions: Chain Drive Camshaft for 2017 Harley-Davidson® Milwaukee Eight® Engines

DISCLAIMER:

Many S&S parts are designed for high performance, closed course, racing applications and are intended for the very experienced rider only. The installation of S&S parts may void or adversely affect your factory warranty. In addition such installation and use may violate certain federal, state, and local laws, rules and ordinances as well as other laws when used on motor vehicles used on public highways. Always check federal, state, and local laws before modifying your motorcycle. It is the sole and exclusive responsibility of the user to determine the suitability of the product for his or her use, and the user shall assume all legal, personal injury risk and liability and all other obligations, duties, and risks associated therewith.

NOT LEGAL FOR SALE OR USE IN CALIFORNIA ON ANY POLLUTION CONTROLLED MOTOR VEHICLES

SAFE INSTALLATION AND OPERATION RULES:

Before installing your new S&S part, it is your responsibility to read and follow the installation and maintenance procedures in these instructions and follow the basic rules below for your personal safety.

- Gasoline is extremely flammable and explosive under certain conditions and toxic when breathed. Do not smoke. Perform installation in a well ventilated area away from open flames or sparks.
- If motorcycle has been running, wait until engine and exhaust pipes have cooled down to avoid getting burned before performing any installation steps.
- Before performing any installation steps, disconnect battery to eliminate potential sparks and inadvertent engagement of starter while working on electrical components.
- Read instructions thoroughly and carefully so all procedures are completely understood before performing any installation steps. Contact S&S with any questions you may have if any steps are unclear or any abnormalities occur during installation or operation of motorcycle with an S&S part on it.
- Consult an appropriate service manual for your motorcycle for correct disassembly and reassembly procedures for any parts that need to be removed to facilitate installation.
- Use good judgment when performing installation and operating motorcycle. Good judgment begins with a clear head. Don't let alcohol, drugs or fatigue impair your judgment. Start installation when you are fresh.
- Be sure all federal, state and local laws are obeyed with the installation.
- For optimum performance and safety and to minimize potential damage to carb or other components, use all mounting hardware that is provided and follow all installation instructions.
- Motorcycle exhaust fumes are toxic and poisonous and must not be breathed. Run motorcycle in a well ventilated area where fumes can dissipate.

IMPORTANT NOTICE:

Statements in this instruction sheet preceded by the following words are of special significance.



WARNING

Means there is the possibility of injury to yourself or others.



CAUTION

Means there is the possibility of damage to the part or motorcycle.

NOTE

Other information of particular importance has been placed in italic type.

S&S recommends you take special notice of these items.

WARRANTY:

All S&S parts are guaranteed to the original purchaser to be free of manufacturing defects in materials and workmanship for a period of twelve (12) months from the date of purchase. Merchandise that fails to conform to these conditions will be repaired or replaced at S&S's option if the parts are returned to us by the purchaser within the 12 month warranty period or within 10 days thereafter.

In the event warranty service is required, the original purchaser must call or write S&S immediately with the problem. Some problems can be rectified by a telephone call and need no further course of action.

A part that is suspect of being defective must not be replaced by a Dealer without prior authorization from S&S. If it is deemed necessary for S&S to make an evaluation to determine whether the part was defective, a return authorization number must be obtained from S&S. The parts must be packaged properly so as to not cause further damage and be returned prepaid to S&S with a copy of the original invoice of purchase and a detailed letter outlining the nature of the problem, how the part was used and the circumstances at the time of failure. If after an evaluation has been made by S&S and the part was found to be defective, repair, replacement or refund will be granted.

ADDITIONAL WARRANTY PROVISIONS:

- (1) S&S shall have no obligation in the event an S&S part is modified by any other person or organization.
- (2) S&S shall have no obligation if an S&S part becomes defective in whole or in part as a result of improper installation, improper maintenance, improper use, abnormal operation, or any other misuse or mistreatment of the S&S part.
- (3) S&S shall not be liable for any consequential or incidental damages resulting from the failure of an S&S part, the breach of any warranties, the failure to deliver, delay in delivery, delivery in non-conforming condition, or for any other breach of contract or duty between S&S and a customer.

Special Tools Required

- Harley-Davidson® sprocket locking tool H-D® #42314
- Harley Davidson cam bearing removal and installation tool H-D #42325-4

Disassembly

1. Disconnect negative battery cable or pull main fuse to eliminate potential sparks and inadvertent engagement of starter while working on motorcycle.
2. Remove exhaust system and right floor board. Refer to factory service manual for procedure.
3. Remove spark plugs and pushrod cover clips. Collapse pushrod covers to expose pushrods.
4. If you wish to save the stock pushrods, follow the procedure in the Harley-Davidson® service manual for pushrod removal. However, stock pushrods may be cut out of the engine to save time, and replaced with S&S Quickee pushrods with no top end disassembly. **See step 5.**
5. If stock pushrods are to be cut out, safely elevate and stabilize rear of motorcycle. Place transmission in high gear. Turn rear wheel to rotate engine until both lifters and pushrods for either cylinder are at lowest point on camshaft (TDCC – Top Dead Center Compression). Both intake and exhaust pushrods for that cylinder will rotate with light finger pressure because the valves are both closed and the pushrods will not be under pressure from the valve springs. Cut pushrods for cylinder that is at TDCC with bolt cutter and remove pushrods and pushrod covers from engine. Rotate engine to place pushrods for other cylinder at their lowest point (TDCC). Cut and remove remaining pushrods.

NOTE: Be sure to heed cautions and warnings in these instructions. If stock pushrods are cut out, we suggest that they be replaced with S&S Quickee pushrod kit #930-0123.



Cutting pushrods with a saw or cutoff wheel may result in debris entering engine, causing extensive engine damage not covered under warranty.



Cutting pushrods when they are under spring pressure can result in pushrod parts being ejected with considerable force, and can cause bodily injury. Make sure piston is at TDCC.

6. Following procedures in factory service manual, remove cam cover, chain drive sprockets and drive chain, and cam support plate. Remove camshaft. Tappets will generally remain in place, held by the plastic tappet alignment plate in tappet covers. Otherwise a magnetic tappet lifter may be used.

*NOTE - While it is not generally necessary to remove the oil pump during cam installation, for high mileage engines or if the oil pump is removed for another reason, replace the crankcase scavenge o-ring with the o-ring supplied in the kit. **See Picture 1.***



Picture 1

7. If removed, reinstall the oil pump per procedure in factory service manual.

Inner Cam Bearing Removal

NOTE – Before the first cam bearing installation with a new installation tool, it may be helpful to install the plate on an engine before removing the stock bearing, and run the installation tool in until it touches the stock bearing. Mark the position on the threaded shaft of the installer for future reference.

1. A special full complement inner cam bearing is included in the kit. This is a bearing has more rollers than the stock bearing. It is highly recommended that the stock bearing be replaced with this bearing. Harley Davidson cam bearing removal and installation tool H-D #42325-4 or equivalent is required.
2. Ensure that the expander rod in the collet is loose, and push the collet through cam bearing. **See Picture 2.**



Picture 2



Make sure the collet has been inserted all the way through the inner cam bearing and grips the rear edge of the bearing shell. See Picture 3. If the collet is expanded with the back edge inside the bearing, it can allow the needle bearings to escape, potentially necessitating complete engine teardown.



Picture 3

3. Slide the plate over the collet, and attach the plate to the surface of the cam chest. See **Picture 4**.

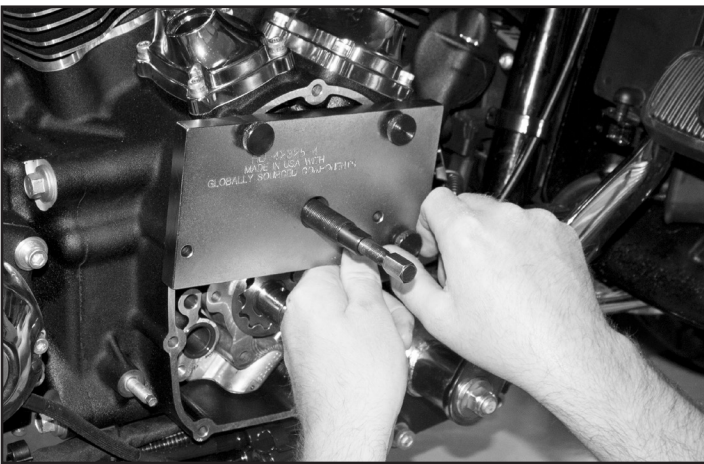

Picture 4

4. Expand the collet by holding the collet shaft with a 7/16" wrench and turning the threaded expander rod with another 7/16" wrench.
5. Install the collet bearing, washer and nut on the collet shaft, and hold the collet shaft with a 7/16" wrench and turn the nut with a 15/16" wrench to pull the bearing out of the crankcase. See **Picture 5**.

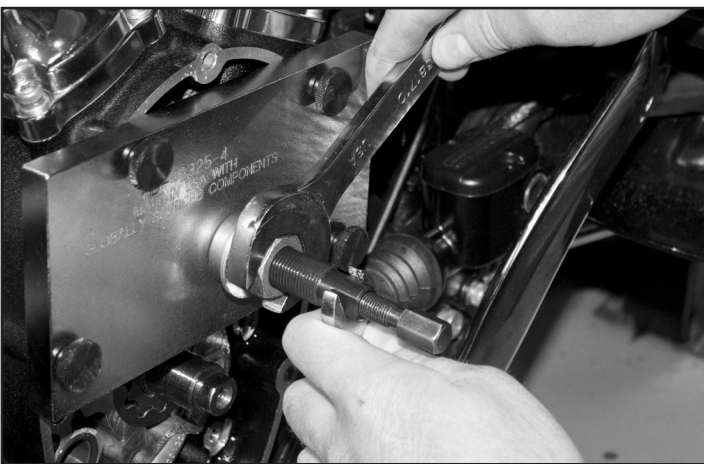

Picture 5

Inner Cam Bearing Installation

1. Calculate the installed depth of the cam bearing.
 - a. Measure the thickness of the bearing installation plate.
 - b. Add the thickness of the plate to 3.750". Record this number as the installed depth of the cam bearing ± 0.020 ".
2. Thread the bearing installation tool into the threaded hole in the plate.
3. Place the new bearing on the installation tool with the numbers toward the flange off the tool. The number side of the bearing faces outward when installed in the engine. Apply press lube or engine oil to the bearing shell.
4. Install the plate on the cam chest of the engine. It is sometimes helpful to leave the plate fasteners a little loose until the bearing is centered and started in the bore in the crankcase.
5. Snug up the mounting bolts holding the plate to the crankcase once the bearing is centered. Turn the installer tool with a 15/16" wrench to start the bearing in the crankcase bore.
6. Continue to press the bearing into the crankcase until the outer surface of the bearing is flush with crankcase surface.
7. Remove the installer tool from the plate, and use a caliper to measure the distance from the outer surface of the plate to the outer edge of the bearing. Subtract this value from the installed depth value calculated earlier. This is how much farther the bearing must be pressed into the case. See **Picture 6**.



Picture 6

8. Reinstall the installer tool. Snug it up to the bearing.
9. Measure the height of the hex portion of the tool from the outer surface of the plate. See **Picture 7**. Subtract the distance that bearing must still be pressed in from the height of the hex from the plate. Note this dimension.



Picture 7

- Turn the installer tool until the hex is at the height calculated in step 9.
- Remove the installer tool and recheck the bearing installed depth as in step 7. This depth should be the same as the calculated depth in Step 1 $\pm .020"$. Adjust as needed.

Camshaft Installation

- Apply assembly lube to the rollers of the inner cam bearing and to the cam bearing surface and lobes of the camshaft. Insert the camshaft into the inner cam bearing.
- Apply assembly lube to the outer cam bearing surface of the cam shaft.
- Replace the cam plate to crankcase o-ring. See **Picture 8**.

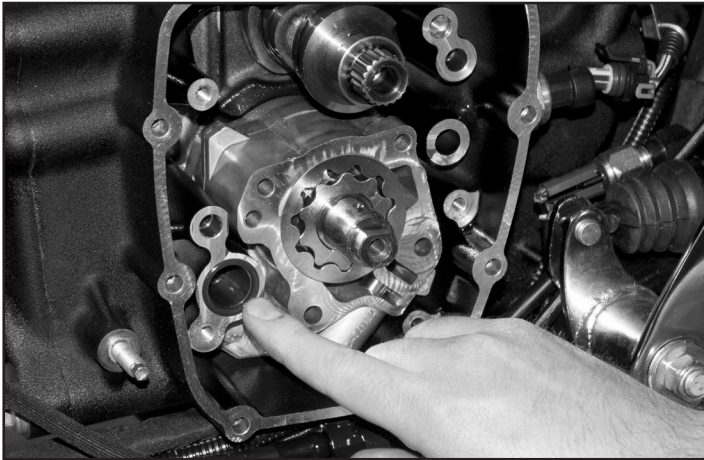

Picture 8

- Apply assembly lube to the o-ring, and to cam plate bushings and thrust surfaces.
- Slide cam plate over cam and pinion shaft.

HINT- It's easier to hold the cam in position if the chain sprocket bolt is threaded into the end of the cam to use as a convenient handle.

- Apply blue thread locker to the 4 oil pump bolts and the 6 cam plate bolts. Start all screws, but leave loose.
- Tighten oil pump screws 1 and 2 to 60 in-lb. See **Picture 9**.

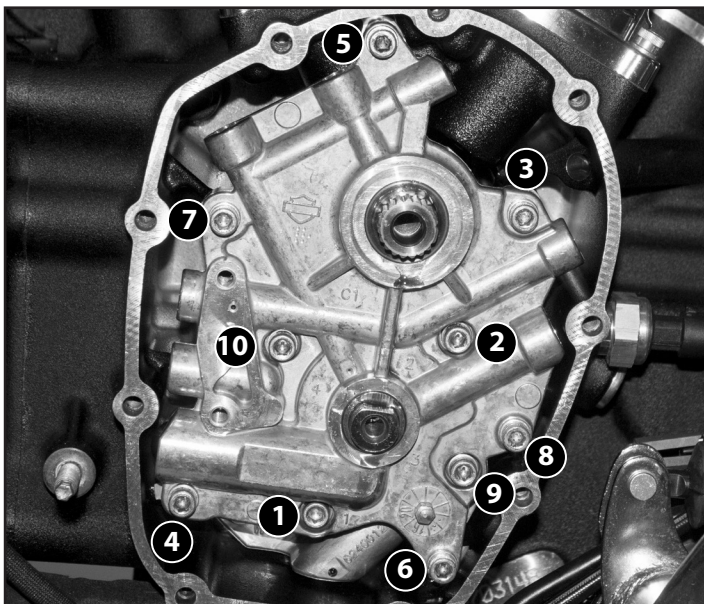

Picture 9

- Use the rear wheel of bike to turn the engine one complete revolution.
- Tighten bolts 3 through 8 to 120 in-lb.
- Tighten bolts 1, 2, 9, and 10 to 120 in-lb.
- Turn engine over one full revolution to make sure oil pump does not bind. Stop with the flat on the pinion shaft horizontal, facing up As shown in **Picture 9**.
- Place spacer on camshaft, and install cam and pinion shaft sprockets without drive chain. Install sprocket locking tool and tighten to 15 ft-lb.
- Spin cam sprocket to make sure the cam turns freely.
- Lay a straight edge across the teeth of both sprockets as shown in **Picture 10**. Measure difference in alignment between the two sprockets with a feeler gauge. Maximum allowable difference in alignment is .009". If more than .009" alignment exists, it must be corrected by installing thicker or thinner spacer on camshaft.

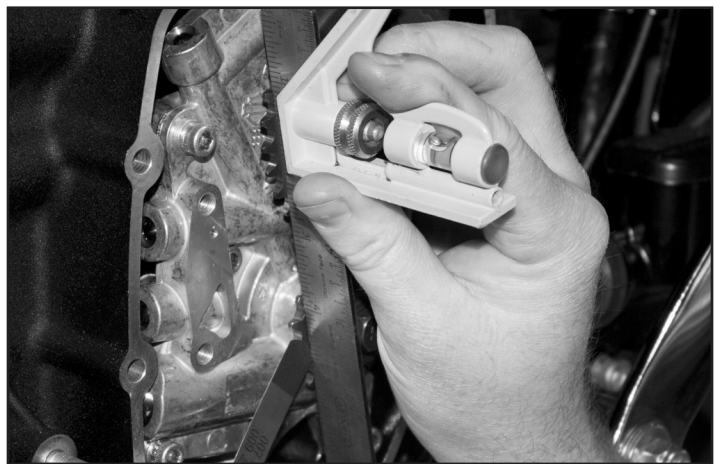

Picture 10

- Remove cam and pinion sprockets. And assemble both sprockets in drive chain. Align timing marks as shown in **Picture 11**.

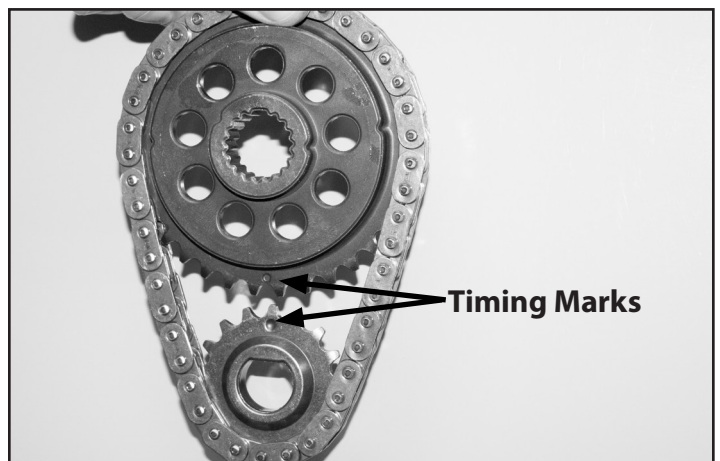

Picture 11

- Install and chain assembly over cam and pinion shaft. Turn camshaft so the wide spline matches the wide space in the sprocket. Make sure the timing marks still line up.
- Apply red thread locker to the pinion and cam sprocket bolts, install sprocket locking tool, and tighten sprocket bolts. Cam sprocket bolt – 34 ft-lb and pinion sprocket bolt 24 ft-lb.

18. Apply blue thread locker to chain tensioner bolts, and install the chain tensioner as shown in **Picture 12**. Tighten to 120 in-lb.

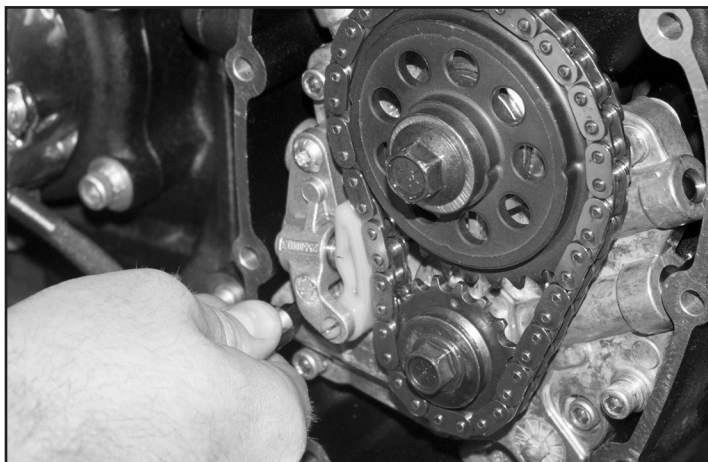

Picture 12

19. Apply assembly lube to the cam chain and cam chain tensioner shoe.
20. Apply blue thread locker to cam cover screws, and install cam cover, gasket, and screws.
21. Tighten cam cover screws to 120 in-lb using sequence shown in **Picture 13**.

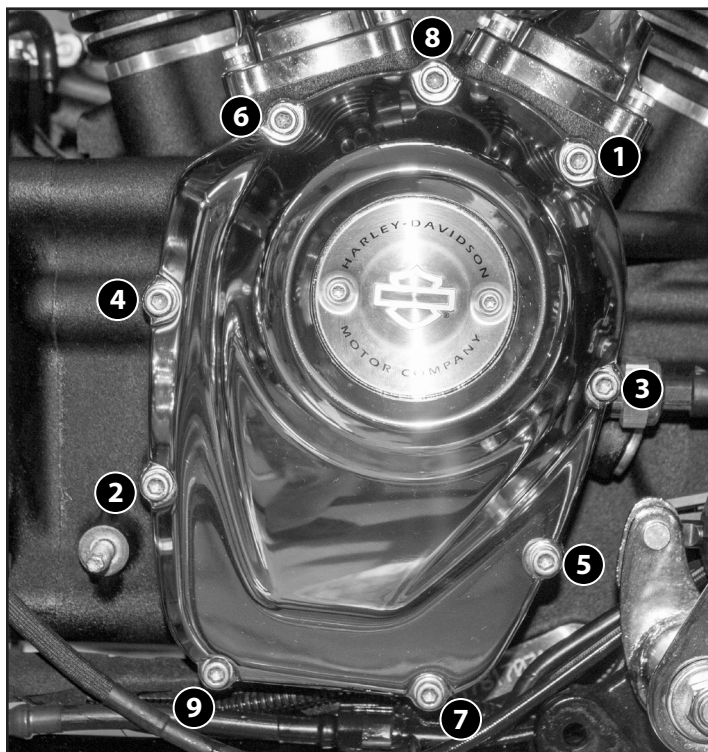

Picture 13

22. Reinstall stock pushrods according to procedure in factory manual, or install S&S Quickee pushrods according to instructions provided.
23. Reinstall exhaust and right floorboard.

NOTE - Installation of performance camshafts requires recalibration of the EFI module. S&S recommends the DynoJet® Power Vision® tuner. Call our Tech department at 608-627-1497 for calibration recommendations..

Replacement Parts

1. Gasket Cam Cover M8 310-0911
2. Cam Shaft.....NA
3. Inner Cam Bearing 31-04199-S
4. O-Ring, (-116) .737" ID x .942 OD, Viton 50-7954-S
5. O-Ring, 11/16 ID x 15/16" OD, Viton 50-8039

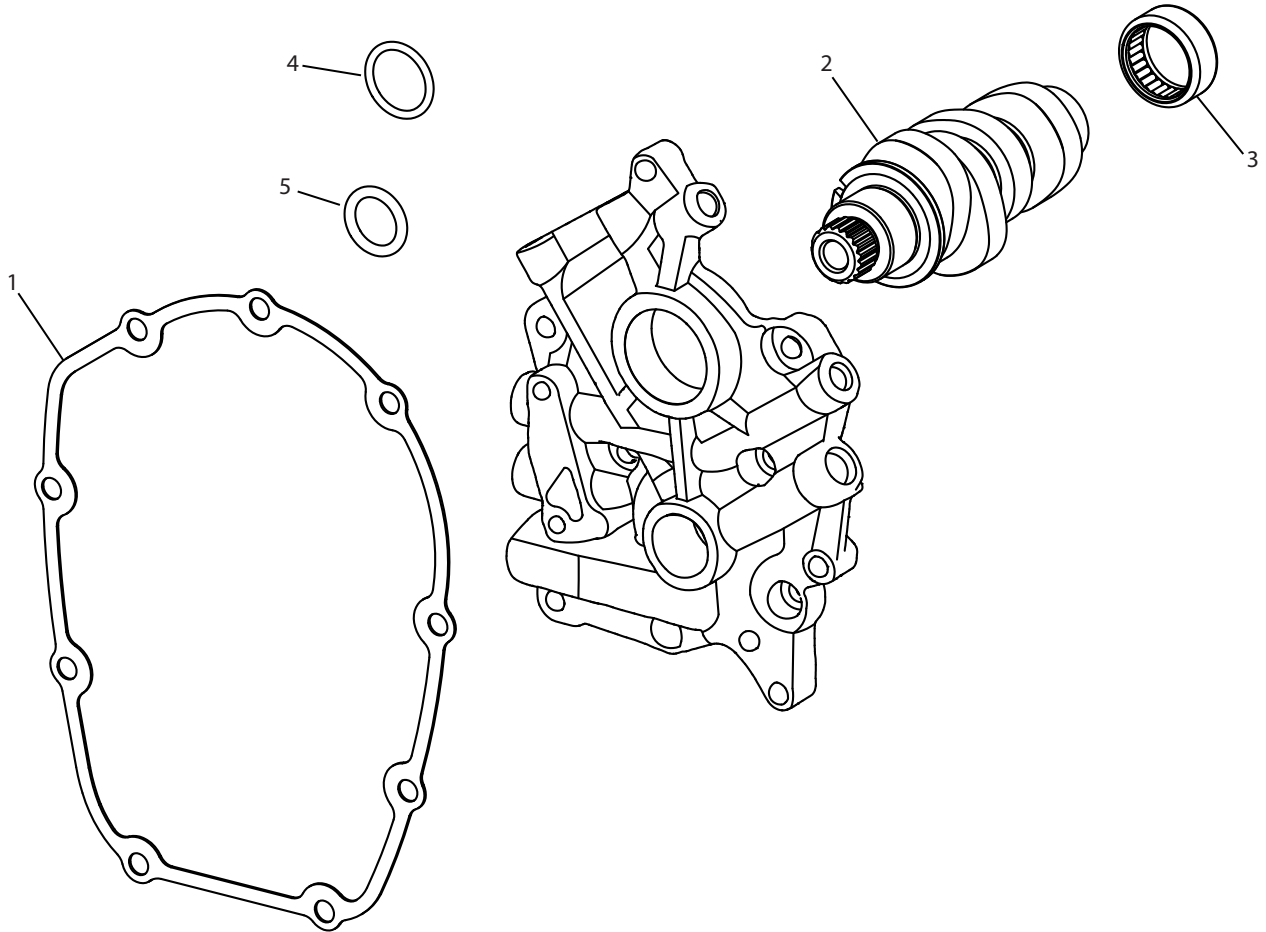

Instruction 510-0597

07-03-18

Version 3

© 2018

by S&S® Cycle, Inc.

All rights reserved.

Printed in the U.S.A.

S&S® Cycle, Inc.

14025 Cty Hwy G

Viola, Wisconsin 54664

Phone: 608-627-1497 • Fax: 608-627-1488

Technical Service Phone: 608-627-TECH (8324)

Technical Service Email: sstech@sscycycle.com

Website: www.sscycycle.com



Installation Instructions: S&S Oil Pumps for 2017-up M8 Engines

(310-0947 Oil Pump, Kit, Water Cooled, 2017-up M8 Models & 310-0959 Oil Pump, Kit, Oil Cooled, 2017-up M8 Models)

DISCLAIMER:

Many S&S parts are designed for high performance, closed course, racing applications and are intended for the very experienced rider only. The installation of S&S parts may void or adversely affect your factory warranty. In addition such installation and use may violate certain federal, state, and local laws, rules and ordinances as well as other laws when used on motor vehicles used on public highways. Always check federal, state, and local laws before modifying your motorcycle. It is the sole and exclusive responsibility of the user to determine the suitability of the product for his or her use, and the user shall assume all legal, personal injury risk and liability and all other obligations, duties, and risks associated therewith.

SAFE INSTALLATION AND OPERATION RULES:

Before installing your new S&S part, it is your responsibility to read and follow the installation and maintenance procedures in these instructions and follow the basic rules below for your personal safety.

- Gasoline is extremely flammable and explosive under certain conditions and toxic when breathed. Do not smoke. Perform installation in a well ventilated area away from open flames or sparks.
- If motorcycle has been running, wait until engine and exhaust pipes have cooled down to avoid getting burned before performing any installation steps.
- Before performing any installation steps, disconnect battery to eliminate potential sparks and inadvertent engagement of starter while working on electrical components.
- Read instructions thoroughly and carefully so all procedures are completely understood before performing any installation steps. Contact S&S with any questions you may have if any steps are unclear or any abnormalities occur during installation or operation of motorcycle with an S&S part on it.
- Consult an appropriate service manual for your motorcycle for correct disassembly and reassembly procedures for any parts that need to be removed to facilitate installation.
- Use good judgment when performing installation and operating motorcycle. Good judgment begins with a clear head. Don't let alcohol, drugs or fatigue impair your judgment. Start installation when you are fresh.
- Be sure all federal, state and local laws are obeyed with the installation.
- For optimum performance and safety and to minimize potential damage to carb or other components, use all mounting hardware that is provided and follow all installation instructions.
- Motorcycle exhaust fumes are toxic and poisonous and must not be breathed. Run motorcycle in a well ventilated area where fumes can dissipate.

IMPORTANT NOTICE:

Statements in this instruction sheet preceded by the following words are of special significance.



WARNING

Means there is the possibility of injury to yourself or others.



CAUTION

Means there is the possibility of damage to the part or motorcycle.

NOTE

Other information of particular importance has been placed in italic type.

S&S recommends you take special notice of these items.

WARRANTY:

All S&S parts are guaranteed to the original purchaser to be free of manufacturing defects in materials and workmanship for a period of twelve (12) months from the date of purchase. Merchandise that fails to conform to these conditions will be repaired or replaced at S&S's option if the parts are returned to us by the purchaser within the 12 month warranty period or within 10 days thereafter.

In the event warranty service is required, the original purchaser must call or write S&S immediately with the problem. Some problems can be rectified by a telephone call and need no further course of action.

A part that is suspect of being defective must not be replaced by a Dealer without prior authorization from S&S. If it is deemed necessary for S&S to make an evaluation to determine whether the part was defective, a return authorization number must be obtained from S&S. The parts must be packaged properly so as to not cause further damage and be returned prepaid to S&S with a copy of the original invoice of purchase and a detailed letter outlining the nature of the problem, how the part was used and the circumstances at the time of failure. If after an evaluation has been made by S&S and the part was found to be defective, repair, replacement or refund will be granted.

ADDITIONAL WARRANTY PROVISIONS:

- (1) S&S shall have no obligation in the event an S&S part is modified by any other person or organization.
- (2) S&S shall have no obligation if an S&S part becomes defective in whole or in part as a result of improper installation, improper maintenance, improper use, abnormal operation, or any other misuse or mistreatment of the S&S part.
- (3) S&S shall not be liable for any consequential or incidental damages resulting from the failure of an S&S part, the breach of any warranties, the failure to deliver, delay in delivery, delivery in non-conforming condition, or for any other breach of contract or duty between S&S and a customer.

NOTES:

- Installation of S&S oil pump requires the use of special tools and repair manuals for the model bike you will be doing the work on. Attempting the installation without the proper tools and manuals will be difficult. Damage can result which will not be covered under warranty.
- Possible failure may result if thread locking compound is not applied to the cam drive sprocket flange bolts. Always prepare threads according to the instructions on the container.
- S&S oil pumps are designed to work with pinion shaft runout up to 0.005".

All reference to Harley-Davidson® part numbers is for identification purposes only. We in no way are implying that any of S&S Cycle's products are original equipment parts or that they are equivalent to the corresponding Harley-Davidson® part numbers.

Follow Steps 1-7 To Prepare For Installation

1. Refer to proper H-D® manual for the model of bike you will be working on for the removal of existing oil pump.
2. Once you have successfully removed the cam plate and oil pump from the engine it will be necessary to measure the pinion shaft run out. Refer to manual for proper procedure and service limits.
3. If you will be reusing your existing cam plate, wash the cam plate and inspect the bearing surfaces. Refer to the manufacturers specifications for service wear limits. Inspect the pump mating surface for scoring; excessive scoring could adversely affect oil pressure.

NOTE: If your cam plate has non-serviceable oil galley plugs and has been exposed to debris from previous engine failure or other foreign material, it is almost impossible to effectively clean those passages. A new cam plate may be a better option.

4. Inspect or replace chain tension as needed. Refer to the H-D® manual for service wear limits.
5. Inspect the inner cam bearing, now is the time to replace this bearing while the engine is apart. Refer to manual for proper procedure and tools to use when replacing these bearings. Note: Full complement bearing is recommended.
6. Clean and flush your oil tank and oil lines. Any foreign matter that has accumulated in the oil tank will be sucked through the new oil pump. Oil pans with riveted-in baffle can be very hard to clean, it is very important to remove all debris from the pan. Also, when installing the S&S oil pump, the oil filter should be changed.
7. Remove pump from package and inspect pump for shipping damage. If there is any damage contact S&S immediately. Make sure pump has all parts shown in assembly drawing on last page.

S&S Oil Pump Installation

1. **Make sure you have the proper oil pump for your engine.** S&S offers two styles of oil pumps, each specific to the engine type. For water cooled engines, the S&S oil pump kit pn is 310-0947. This pump is easily identified by a "W" machined into the front surface of the main pump body. For the oil cooled engines, the S&S oil pump kit pn is 310-0959. This pump is easily identified by an "O" machined into the front surface of the main pump body.
2. **Important:** If the oil pump is disassembled for cleaning, do not remove the pressure relieve valve assembly. This has been preset at the factory. Disassemble and wash all components of the oil pump. Make sure the pipe plug is installed and is flush or below the adjacent pump body surface.

3. The oil pump can be assembled into the cam chest one section at a time or as a complete unit, either method is acceptable as long as the mating sections fit tightly together.
4. **Individual section assembly method** - Install the flywheel scavenge port o-ring into the case (do not install the o-ring onto the pump). Put some assembly lube on the o-ring in order to make installing the return side pump housing easier.
5. Install the return side pump housing. Place your thumb on the lower left corner of the pump housing and push the housing into the o-ring.
6. Apply a liberal amount of assembly lube to the inner return rotor set and assemble into the return side pump housing. Make sure the relief cut side of the inner rotor goes toward the engine. **See Picture 1.**

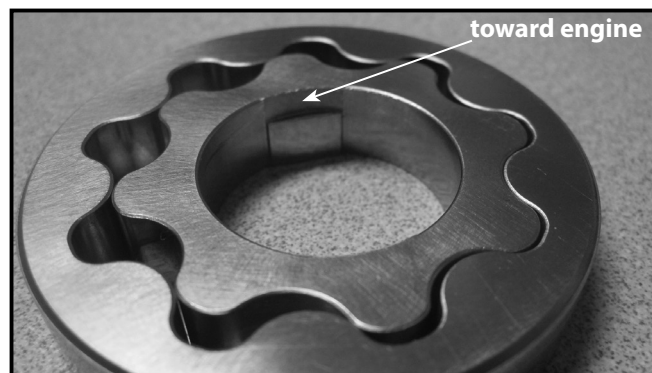

Picture 1

7. Install two 1/8" x 3/4" dowels into the return side pump housing.
8. Install divider plate over the dowel pins.
9. Locate the debris screen and second return rotor set. Apply a liberal amount of assembly lube to the second return rotor set and place gear set into supply side pump body. Apply assembly lube to the flat surface of the screen and place into the supply side pump body. The assembly lube will prevent the screen from falling out during assembly. Carefully install the supply side pump into the cam chest and mated to the return side pump housing.
10. Place a straight edge across the oil pump body and make sure the face of the pump does not protrude past the cam support plate mating surface. **This check is critical to the final assembly. See Picture 2.**



Picture 2

11. If pump protrudes past mating surface check to see that the pump is installed all the way into the scavenge port o-ring or if the debris screen has dropped out.

12. Apply a liberal amount of assembly lube to the outer feed rotor set and install into the supply side pump body. Be sure these gears do not protrude past the front face of the pump.
13. Skip to step 21.
14. **Complete pump assembly method** - Thoroughly clean all components of the oil pump.
15. Assemble the pump according to the diagram in the back of these instructions. Apply as much assembly lube as possible to all the rotor sets. Align all of the inner rotor flats vertical (12 and 6 o'clock position). Make sure the inner return rotor set is installed with the relief cut toward the engine. **See Picture 1** and the appropriate exploded view in the back of these instructions.
16. Install the flywheel scavenge port o-ring into the case (do not install the o-ring onto the pump). Put some assembly lube on the o-ring in order to make installing the return side pump housing easier.
17. With the flats of the pinions shaft vertical (12 and 6 o'clock position), gently slide the oil pump assembly over the pinion shaft. It may be necessary to rock the crankshaft back and forth to allow all the rotors to properly align.

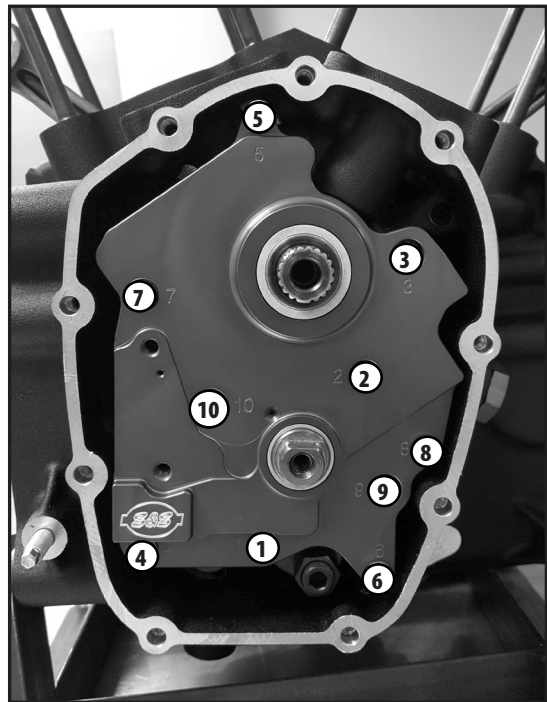

Picture 3: Cam Support Plate Screws (3-8) and Oil Pump Screws (1, 2, 9, 10)

18. Place your thumb on the lower left corner of the pump housing and push the housing into the o-ring.
19. Place a straight edge across the oil pump body and make sure the face of the pump does not protrude past the cam support plate mating surface. **This check is critical to the final assembly. See Picture 2.**
20. If pump protrudes past mating surface check to see that the pump is installed all the way into the scavenge port o-ring or if the debris screen has dropped out.
21. Prepare the camshaft for assembly by thoroughly cleaning. Apply assembly lube to the inner bearing surface and install into the engine.
22. Apply assembly lube to a new o-ring and install into the oil supply passage in the crankcase.
23. Thoroughly clean and dry the cam support plate. Apply assembly lube to the pinion shaft and camshaft bearing surfaces. Apply assembly lube to the wear plate and place onto the back of the cam support plate. The assembly lube will keep the wear plate from falling off during assembly.
24. Install the cam support plate onto the pinion shaft and camshaft. Make sure the support plate fully contacts the mounting surfaces of the engine case and the dowel is engaged into the mounting hole.

Note: *The oil supply passage o-ring will hold the plate slightly off the mounting surface until the support plates screws are fully tightened.*

25. Turn the crankshaft so that the flat on the pinion shaft is facing straight up (12 o'clock position).
26. Apply a small amount of blue Loctite® to the cam support screws and the new oil pump screws. Make sure the flat washers are installed on the oil pump screws.

27. Steps 28 thru 34 are critical to proper final assembly.

28. Make sure the flat on the pinion shaft is facing straight up. **See picture 3** for correct orientation of pinion shaft.
29. Loosely install all cam support plate and oil pump screws but do not apply any torque.

30. Snug the oil pump screws 1, 2, 9 and 10 but do not torque.
31. Snug the cam support plate screws 3, 4, 5, 6, 7 and 8 but do not torque.
32. Torque screws 3, 4, 5, 6, 7 and 8 in order to 90-120 in*lbs. **See Picture 3a.**



Picture 3a: Cam Plate Screws-Torque According to Step 32

33. Rotate the crankshaft two complete revolutions with the flat on the pinion shaft facing straight up (12 o'clock position) when done.

34. Torque the oil pump screws 1, 2, 9 and 10 in that order to 90-120 in*lbs. **See Picture 3b.**



Picture 3b: Oil Pump Screws-Torque According to Step 34

35. Rotate the crankshaft through at least 2 revolutions to make sure binding does not occur in the oil pump. If binding does occur, loosen the oil pump and cam support plate screws and go through the installation procedure starting at Step 28.
36. Recheck the torque on all 10 fasteners in the order 1 through 10.
37. Reinstall all remaining components according to the proper service manual or installation instructions.

Oil Pressure:

The pressure relief valve on the S&S oil pump has been set at the factory to relieve at approximately 45 psi.

Important: If changes are made to the pressure relief setting, use a caliper to measure the distance from the end of the pressure relief screw to the surface of the oil pump body and record this dimension for future reference.

The pressure relief valve is designed to keep the pump from building excessive oil pressure at high RPMs. Resist the temptation to turn in the screw in order to raise the low rpm oil pressure. If your engine has no oil pressure at idle, turning the pressure relief screw in more will normally not help this condition as this pressure will be below the operation point of the pressure relief valve. If you do adjust the pressure relief valve to something other than the factory setting, we recommend not tuning the adjuster more than ½ turn at a time. One half turn of the screw will move the adjuster .025" which typically changes the oil pressure approximately 5psi. There are other factors which will affect your oil pressure, the biggest influences being oil temperature.

Oil Pump Replacement Parts - Water Cooled Pump Kit PN 310-0947

- 1. Dowel pin, 0.125"x0.750", 2 Pack **500-0967**
- 2. Pressure Relief Valve Assembly **500-0949**
- 3. Stainless Steel Mesh Screen (2) **310-0546**
- 4. Rotor Set, Oil Pump, Machined **310-0644**
- 5. Oil Pump Housing, Supply Side, Water Cooled,
2017-up M8 Models **310-0942**
- 6. Oil Pump Housing, Return Side, 2017-up M8 Models **310-0945**
- 7. Divider Plate **310-0948**
- 8. Rotor Set, Oil Pump (2) **36-7021-S**
- 9. 1/4" Pipe Plug 5 pack **500-0969**
- 10. Retaining Ring 5 pack **500-0968**
- 11. Magnet, .250" x .500" **500-0350**

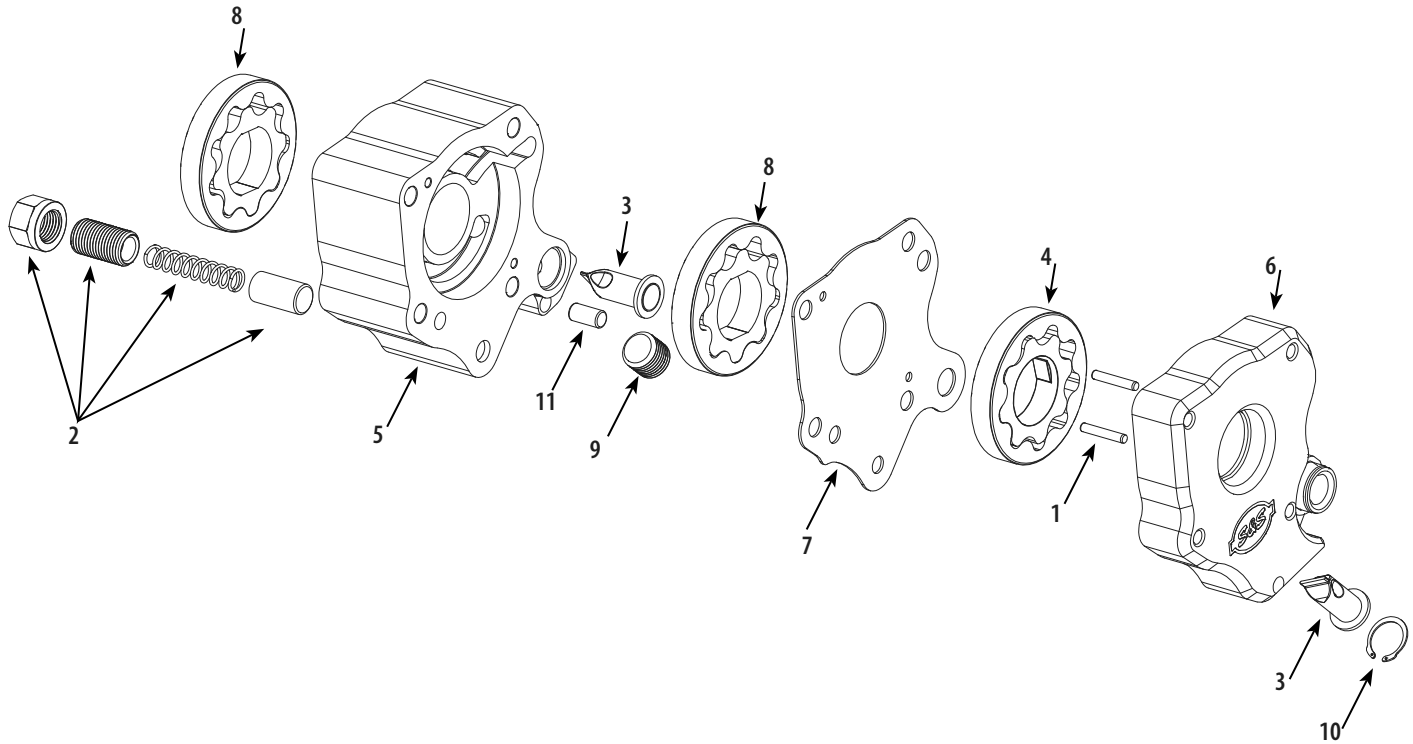

Oil Pump Replacement Parts - Oil Cooled Pump Kit PN 310-0959

1. Dowel pin, 0.125"x0.750", 2 Pack **500-0967**
2. Pressure Relief Valve Assembly **500-0949**
3. Stainless Steel Mesh Screen (2) **310-0546**
4. Rotor Set, Oil Pump, Machined **310-0644**
5. Oil Pump Housing, Return Side, 2017-up M8 Models **310-0945**
6. Oil Pump Housing, Supply Side, Oil Cooled, 2017-up M8 Models **310-0957**
7. Divider Plate **310-0948**
8. Rotor Set, Oil Pump, Oil Cooled 2017-up M8 Models **310-0955**
9. Rotor Set, Oil Pump **36-7021-S**
10. 1/4" Pipe Plug 5 Pack **500-0969**
11. Retaining Ring 5 Pack **500-0968**
12. Magnet, .250" x .500" **500-0350**

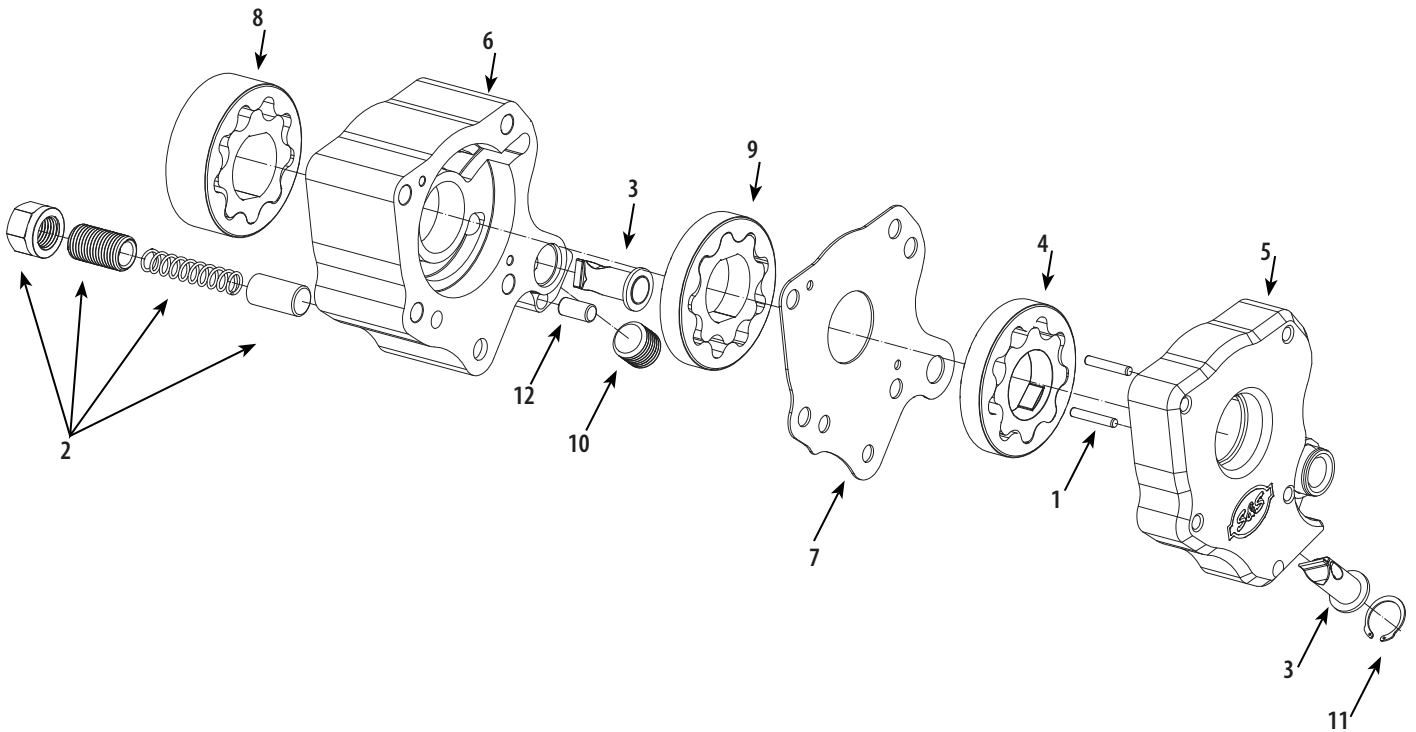

Instruction 510-0575

12-04-17

Version 1

Copyright © 2017

by S&S® Cycle, Inc.

All rights reserved.

Printed in the U.S.A.

S&S® Cycle, Inc.

14025 Cty Hwy G

Viola, Wisconsin 54664

Phone: 608-627-1497 • Fax: 608-627-1488

Technical Service Phone: 608-627-TECH (8324)

Technical Service Email: sstech@sscycle.com

Website: www.sscycle.com



Installation Instructions: S&S Tappet Cuffs for 2017-2018 Harley-Davidson® Milwaukee-Eight® Engines

DISCLAIMER:

Many S&S parts are designed for high performance, closed course, racing applications and are intended for the very experienced rider only. The installation of S&S parts may void or adversely affect your factory warranty. In addition such installation and use may violate certain federal, state, and local laws, rules and ordinances as well as other laws when used on motor vehicles used on public highways. Always check federal, state, and local laws before modifying your motorcycle. It is the sole and exclusive responsibility of the user to determine the suitability of the product for his or her use, and the user shall assume all legal, personal injury risk and liability and all other obligations, duties, and risks associated therewith.

SAFE INSTALLATION AND OPERATION RULES:

Before installing your new S&S part, it is your responsibility to read and follow the installation and maintenance procedures in these instructions and follow the basic rules below for your personal safety.

- Gasoline is extremely flammable and explosive under certain conditions and toxic when breathed. Do not smoke. Perform installation in a well ventilated area away from open flames or sparks.
- If motorcycle has been running, wait until engine and exhaust pipes have cooled down to avoid getting burned before performing any installation steps.
- Before performing any installation steps, disconnect battery to eliminate potential sparks and inadvertent engagement of starter while working on electrical components.
- Read instructions thoroughly and carefully so all procedures are completely understood before performing any installation steps. Contact S&S with any questions you may have if any steps are unclear or any abnormalities occur during installation or operation of motorcycle with an S&S part on it.
- Consult an appropriate service manual for your motorcycle for correct disassembly and reassembly procedures for any parts that need to be removed to facilitate installation.
- Use good judgment when performing installation and operating motorcycle. Good judgment begins with a clear head. Don't let alcohol, drugs or fatigue impair your judgment. Start installation when you are fresh.
- Be sure all federal, state and local laws are obeyed with the installation.
- For optimum performance and safety and to minimize potential damage to carb or other components, use all mounting hardware that is provided and follow all installation instructions.
- Motorcycle exhaust fumes are toxic and poisonous and must not be breathed. Run motorcycle in a well ventilated area where fumes can dissipate.

IMPORTANT NOTICE:

Statements in this instruction sheet preceded by the following words are of special significance.



WARNING

Means there is the possibility of injury to yourself or others.



CAUTION

Means there is the possibility of damage to the part or motorcycle.

NOTE

Other information of particular importance has been placed in italic type.

S&S recommends you take special notice of these items.

WARRANTY:

All S&S parts are guaranteed to the original purchaser to be free of manufacturing defects in materials and workmanship for a period of twelve (12) months from the date of purchase. Merchandise that fails to conform to these conditions will be repaired or replaced at S&S's option if the parts are returned to us by the purchaser within the 12 month warranty period or within 10 days thereafter.

In the event warranty service is required, the original purchaser must call or write S&S immediately with the problem. Some problems can be rectified by a telephone call and need no further course of action.

A part that is suspect of being defective must not be replaced by a Dealer without prior authorization from S&S. If it is deemed necessary for S&S to make an evaluation to determine whether the part was defective, a return authorization number must be obtained from S&S. The parts must be packaged properly so as to not cause further damage and be returned prepaid to S&S with a copy of the original invoice of purchase and a detailed letter outlining the nature of the problem, how the part was used and the circumstances at the time of failure. If after an evaluation has been made by S&S and the part was found to be defective, repair, replacement or refund will be granted.

ADDITIONAL WARRANTY PROVISIONS:

- (1) S&S shall have no obligation in the event an S&S part is modified by any other person or organization.
- (2) S&S shall have no obligation if an S&S part becomes defective in whole or in part as a result of improper installation, improper maintenance, improper use, abnormal operation, or any other misuse or mistreatment of the S&S part.
- (3) S&S shall not be liable for any consequential or incidental damages resulting from the failure of an S&S part, the breach of any warranties, the failure to deliver, delay in delivery, delivery in non-conforming condition, or for any other breach of contract or duty between S&S and a customer.

Installation

1. Mount motorcycle on a lift and secure with straps. Remove the battery ground cable.

NOTE – If you wish to reuse the stock pushrods, follow the procedure outlined in the factory service manual for pushrod removal. However, due to the amount of labor involved in that procedure, we recommend that the stock pushrods be cut out and replaced with S&S Quicke adjustable pushrods. If removing the pushrods per the factory procedure skip, to step 7.

2. Remove the spark plugs, and Jack the rear end of the motorcycle up so the rear wheel is off the work surface. Shift the transmission into high gear. The rear wheel will be used to turn the engine.
3. Remove the pushrod cover keepers, and slide the pushrod covers up so the pushrods are visible.
4. Turn the rear wheel until either cylinder is at TDC compression. Both valves will be closed, and both tappets will be at the lowest point of travel. There should be no valve spring force on the pushrods and it should be possible to turn them with your fingers.
5. Use a bolt cutter to cut the pushrods, and remove them from the engine. If using the S&S Quicke pushrod and cover kit, save the stock pushrod cover caps, springs and washers for reuse.



Do not cut pushrods with a saw or grinder. Metal particles will be generated which may cause serious engine damage that is not covered under warranty.



Do not attempt to cut pushrods while they are under tension from the valve springs. Pushrod segments may be forcibly ejected from the engine, possibly causing personal injury.

6. Repeat steps 4 and 5 for the other cylinder.
7. Using a 3/16" Allen driver, remove the four screws holding the tappet covers, and remove the covers. Save the screws and gaskets for reuse.
8. Using a 3/8" hex socket, remove the screws securing the stock tappet anti rotation brackets, and remove the brackets.

NOTE – Tappets may easily be replaced at this time if desired.

9. Inspect tappet cover gasket and pushrod cover o-rings for damage. Replace as needed. Clean stock parts to be reinstalled with solvent.
10. S&S Tappet Cuffs are marked F and R for front and rear. Install cuffs in the correct position.
11. Apply blue threadlocker to the stock retaining screws and install screws.
12. Starting with the rear cylinder, insert a .002" feeler gauge between the tappet and cuff to prevent the cuff from rotating and binding on the tappet when the screw is tightened as shown in **Picture 1**.



Picture 1

13. Tighten the screw to 100 in-lb and remove the feeler gauge. Repeat for front cylinder.
 14. Turn engine two complete rotations to ensure that the tappets move freely and do not contact the cuff or bind at any point.
 15. Reinstall the tappet covers and gaskets.
 16. Apply blue threadlocker to the tappet cover screws and install screws.
 17. Tighten tappet cover screws to 140 in-lb.
 18. If reusing stock pushrods, reinstall pushrods and covers, and reassemble pushrods tubes and rocker covers per factory procedure. If using S&S Quicke pushrods, skip to the next step.
 19. If necessary, turn the rear wheel until either of the cylinders is at TDC compression. Both tappets will be at the lowest point of travel.
- NOTE - tappet covers on M8 engines are quite tall and it can be difficult to see position of the tappets. Placing the short ends of cut off stock pushrods in tappet cover holes makes it easy to observe tappet movement.*
20. Install new o-ring seals in tappet cover and rocker cover. Assemble pushrod covers using stock pushrod cover caps, springs, and washers, and the o-ring provided in kit.
 21. Install Quicke pushrods and S&S pushrod covers according to instructions provided in the kit.
- NOTES**
- S&S or similar pushrod covers must be used with Quicke Pushrods. Stock covers are too short to allow for pushrod adjustment.
 - The tappet covers on Milwaukee-Eight engines are quite tall, and care should be taken not to allow the lock-nut to drop to the bottom of the adjuster when installing Quicke pushrods. It is suggested that the 1/4" wrench be applied to the adjuster screw with the nut above it until the adjuster is screwed out of the pushrod, and the nut can be threaded onto the adjuster screw.
22. Adjust pushrods according to the instructions provided with the pushrod kit. Close the pushrod covers and install the supplied S&S pushrod cover keepers.
 23. Repeat steps 19 through 22 for the other cylinder.
 24. Reattach battery ground cable, and reinstall spark plugs.

Instruction 510-0559

08-10-17

Version 1

Copyright © 2017

by S&S® Cycle, Inc.

All rights reserved.
Printed in the U.S.A.

S&S® Cycle, Inc.

14025 Cty Hwy G

Viola, Wisconsin 54664

Phone: 608-627-1497 • Fax: 608-627-1488

Technical Service Phone: 608-627-TECH (8324)

Technical Service Email: sstech@sscycle.com

Website: www.sscycle.com



Installation Instructions: S&S® .605" Lift Conical Valve Spring Kits For Harley-Davidson® Milwaukee-Eight® Engines

DISCLAIMER:

Many S&S parts are designed for high performance, closed course, racing applications and are intended for the very experienced rider only. The installation of S&S parts may void or adversely affect your factory warranty. In addition such installation and use may violate certain federal, state, and local laws, rules and ordinances as well as other laws when used on motor vehicles used on public highways. Always check federal, state, and local laws before modifying your motorcycle. It is the sole and exclusive responsibility of the user to determine the suitability of the product for his or her use, and the user shall assume all legal, personal injury risk and liability and all other obligations, duties, and risks associated therewith.

IMPORTANT NOTICE:

Statements in this instruction sheet preceded by the following words are of special significance.



WARNING

Means there is the possibility of injury to yourself or others.

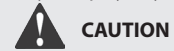

CAUTION

Means there is the possibility of damage to the part or motorcycle.

NOTE

Other information of particular importance has been placed in italic type.

S&S recommends you take special notice of these items.

SAFE INSTALLATION AND OPERATION RULES:

Before installing your new S&S part it is your responsibility to read and follow the installation and maintenance procedures in these instructions and follow the basic rules below for your personal safety.

- Gasoline is extremely flammable and explosive under certain conditions and toxic when breathed. Do not smoke. Perform installation in a well ventilated area away from open flames or sparks.
- If motorcycle has been running, wait until engine and exhaust pipes have cooled down to avoid getting burned before performing any installation steps.
- Before performing any installation steps disconnect battery to eliminate potential sparks and inadvertent engagement of starter while working on electrical components.
- Read instructions thoroughly and carefully so all procedures are completely understood before performing any installation steps. Contact S&S with any questions you may have if any steps are unclear or any abnormalities occur during installation or operation of motorcycle with a S&S part on it.
- Consult an appropriate service manual for your motorcycle for correct disassembly and reassembly procedures for any parts that need to be removed to facilitate installation.
- Use good judgment when performing installation and operating motorcycle. Good judgment begins with a clear head. Don't let alcohol, drugs or fatigue impair your judgment. Start installation when you are fresh.
- Be sure all federal, state and local laws are obeyed with the installation.
- For optimum performance and safety and to minimize potential damage to carb or other components, use all mounting hardware that is provided and follow all installation instructions.
- Motorcycle exhaust fumes are toxic and poisonous and must not be breathed. Run motorcycle in a well ventilated area where fumes can dissipate.

WARRANTY:

All S&S parts are guaranteed to the original purchaser to be free of manufacturing defects in materials and workmanship for a period of twelve (12) months from the date of purchase. Merchandise that fails to conform to these conditions will be repaired or replaced at S&S's option if the parts are returned to us by the purchaser within the 12 month warranty period or within 10 days thereafter.

In the event warranty service is required, the original purchaser must call or write S&S immediately with the problem. Some problems can be rectified by a telephone call and need no further course of action.

A part that is suspect of being defective must not be replaced by a Dealer without prior authorization from S&S. If it is deemed necessary for S&S to make an evaluation to determine whether the part was defective, a return authorization number must be obtained from S&S. The parts must be packaged properly so as to not cause further damage and be returned prepaid to S&S with a copy of the original invoice of purchase and a detailed letter outlining the nature of the problem, how the part was used and the circumstances at the time of failure. If after an evaluation has been made by S&S and the part was found to be defective, repair, replacement or refund will be granted.

ADDITIONAL WARRANTY PROVISIONS:

- (1) S&S shall have no obligation in the event an S&S part is modified by any other person or organization.
- (2) S&S shall have no obligation if an S&S part becomes defective in whole or in part as a result of improper installation, improper maintenance, improper use, abnormal operation, or any other misuse or mistreatment of the S&S part.
- (3) S&S shall not be liable for any consequential or incidental damages resulting from the failure of an S&S part, the breach of any warranties, the failure to deliver, delay in delivery, delivery in non-conforming condition, or for any other breach of contract or duty between S&S and a customer.

This instruction sheet covers S&S valve spring kit 900-0958 for Harley-Davidson® Milwaukee-Eight® engines.

CAUTION

Do not mix springs, collars or any other components between S&S Sidewinder spring kits and other S&S spring kits. Extensive engine damage can result and is not covered under warranty.

WARNING

The safety of the motorcycle rider is dependent of proper installation of this product. If you are not certain of your capabilities or do not have the correct tools for this installation, please consult a professional mechanic. Improper installation of this product could result in injury or death to the rider.

Disassembly

1. Remove heads from engine and disassemble.
2. If cylinder heads/valves are to be reconditioned, proceed at this time according to standard procedure.

Spring Installed Height Measurement and Installation

1. Using the following procedure, determine the spring height and clearance between top collar and valve guide.
 - a. Install the integral valve seal/bottom collar.
 - b. Temporary install the valves.
 - c. Install the top collars and keepers. Pull the top collar tightly against the keepers to seat the keepers in the collar.
 - d. While holding the valve firmly against the seat in the closed position, measure the installed spring height (distance between lower valve spring seating surface and bottom of top collar. **See Figure 1, below.** Record this measurement in the table below.

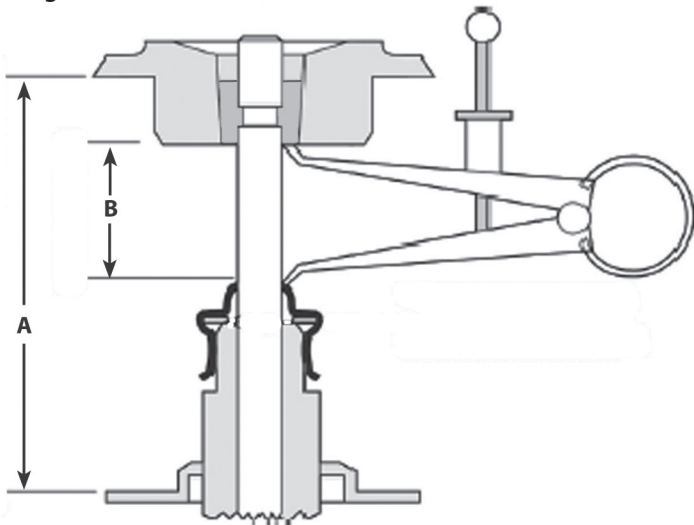

Fig. 1

Dimension A: Installed spring height should be 1.535" ± .010".

Dimension B: Must be .050" greater than valve lift for camshaft to be used.

Camside Valves	Front Exhaust	Front Intake	Rear Exhaust	Rear Intake
Dimension A				
Dimension B				
Driveside Valves	Front Exhaust	Front Intake	Rear Exhaust	Rear Intake
Dimension A				
Dimension B				

- e. Measure distance between top collar keepers and top of the valve guide. **See Figure 1, Dimension B.** Distance must be at least .050" greater than the valve lift of the cam to be used.
- f. Repeat steps a through e for remaining valves and record all measurements in the table. Be sure to keep track of all parts during assembly to assure they are installed in the same location as they were measured.

NOTE: If shims are used with kit #900-0958, they must be placed under the integral lower collar/seal.

2. Install valves and springs with the keepers and top collars provided.

APPLICATION	HARLEY-DAVIDSON M8
TARGET INSTALLED HEIGHT	1.535"
SPRING FORCE AT INSTALLED HEIGHT	68 LB
MAXIMUM VALVE LIFT	0.605"
SPRING FORCE AT MAX VALVE LIFT	264 LB
RATE	324 LB/IN

3. Install the cylinder heads. When the remaining valve train components are assembled, rotate the engine a few times to ensure there is no binding in the valve train.

CAUTION

- Installing springs at height less than recommended dimension will cause rapid spring fatigue resulting in possible engine damage.
- Installing springs at height above recommended dimension will decrease spring tension resulting in possible valve float and engine damage.
- Failure to establish required clearances may cause valve seal failure and other, more extensive engine damage not covered under warranty.

WARNING

Valve spring assembly is under considerable tension when compressed and is potentially dangerous. Wear eye protection and take due caution when checking for coil bind and during installation. After assembly, carefully strike tip of valve stem with plastic hammer to insure that keepers are seated. Direct spring assembly away from face and body during this procedure.