

Instruction 510-0597

01-21-2021

Version 9

© 2018–2021

by S&S® Cycle, Inc.

All rights reserved.

Printed in the U.S.A.

**S&S® Cycle, Inc.**

14025 Cty Hwy G  
Viola, Wisconsin 54664

Phone: 608-627-1497

Technical Service Email: [sstech@sscycle.com](mailto:sstech@sscycle.com)

Website: [www.sscycle.com](http://www.sscycle.com)



## Installation Instructions: S&S Oil Pumps for 2017–up M8 Engines

(310-0947A Oil Pump, Kit, Water Cooled, 2017–up M8 Models & 310-0959A Oil Pump, Kit, Oil Cooled, 2017–up M8 Models)

### DISCLAIMER:

Many S&S parts are designed for high performance, closed course, racing applications and are intended for the very experienced rider only. The installation of S&S parts may void or adversely affect your factory warranty. In addition such installation and use may violate certain federal, state, and local laws, rules and ordinances as well as other laws when used on motor vehicles used on public highways. Always check federal, state, and local laws before modifying your motorcycle. It is the sole and exclusive responsibility of the user to determine the suitability of the product for his or her use, and the user shall assume all legal, personal injury risk and liability and all other obligations, duties, and risks associated therewith.

The words Harley®, Harley-Davidson®, H-D®, Sportster®, Evolution®, and all H-D part numbers and model designations are used in reference only. S&S Cycle is not associated with Harley-Davidson, Inc.

### SAFE INSTALLATION AND OPERATION RULES:

Before installing your new S&S part, it is your responsibility to read and follow the installation and maintenance procedures in these instructions and follow the basic rules below for your personal safety.

- Gasoline is extremely flammable and explosive under certain conditions and toxic when breathed. Do not smoke. Perform installation in a well ventilated area away from open flames or sparks.
- If motorcycle has been running, wait until engine and exhaust pipes have cooled down to avoid getting burned before performing any installation steps.
- Before performing any installation steps, disconnect battery to eliminate potential sparks and inadvertent engagement of starter while working on electrical components.
- Read instructions thoroughly and carefully so all procedures are completely understood before performing any installation steps. Contact S&S with any questions you may have if any steps are unclear or any abnormalities occur during installation or operation of motorcycle with an S&S part on it.
- Consult an appropriate service manual for your motorcycle for correct disassembly and reassembly procedures for any parts that need to be removed to facilitate installation.
- Use good judgment when performing installation and operating motorcycle. Good judgment begins with a clear head. Don't let alcohol, drugs or fatigue impair your judgment. Start installation when you are fresh.
- Be sure all federal, state and local laws are obeyed with the installation.
- For optimum performance and safety and to minimize potential damage to carb or other components, use all mounting hardware that is provided and follow all installation instructions.
- Motorcycle exhaust fumes are toxic and poisonous and must not be breathed. Run motorcycle in a well ventilated area where fumes can dissipate.

### IMPORTANT NOTICE:

Statements in this instruction sheet preceded by the following words are of special significance.



**WARNING**

Means there is the possibility of injury to yourself or others.



**CAUTION**

Means there is the possibility of damage to the part or motorcycle.

**NOTE**

*Other information of particular importance has been placed in italic type.*

*S&S recommends you take special notice of these items.*

### WARRANTY:

All S&S parts are guaranteed to the original purchaser to be free of manufacturing defects in materials and workmanship for a period of twelve (12) months from the date of purchase. Merchandise that fails to conform to these conditions will be repaired or replaced at S&S's option if the parts are returned to us by the purchaser within the 12 month warranty period or within 10 days thereafter.

In the event warranty service is required, the original purchaser must call or write S&S immediately with the problem. Some problems can be rectified by a telephone call and need no further course of action.

A part that is suspect of being defective must not be replaced by a Dealer without prior authorization from S&S. If it is deemed necessary for S&S to make an evaluation to determine whether the part was defective, a return authorization number must be obtained from S&S. The parts must be packaged properly so as to not cause further damage and be returned prepaid to S&S with a copy of the original invoice of purchase and a detailed letter outlining the nature of the problem, how the part was used and the circumstances at the time of failure. If after an evaluation has been made by S&S and the part was found to be defective, repair, replacement or refund will be granted.

### ADDITIONAL WARRANTY PROVISIONS:

- (1) S&S shall have no obligation in the event an S&S part is modified by any other person or organization.
- (2) S&S shall have no obligation if an S&S part becomes defective in whole or in part as a result of improper installation, improper maintenance, improper use, abnormal operation, or any other misuse or mistreatment of the S&S part.
- (3) S&S shall not be liable for any consequential or incidental damages resulting from the failure of an S&S part, the breach of any warranties, the failure to deliver, delay in delivery, delivery in non-conforming condition, or for any other breach of contract or duty between S&S and a customer.

## NOTES:

- Installation of S&S oil pump requires the use of special tools and repair manuals for the model bike you will be doing the work on. Attempting the installation without the proper tools and manuals will be difficult. Damage can result which will not be covered under warranty.
- Possible failure may result if thread locking compound is not applied to the cam drive sprocket flange bolts. Always prepare threads according to the instructions on the container.
- S&S oil pumps are designed to work with pinion shaft runout up to 0.005".

All reference to Harley-Davidson® part numbers is for identification purposes only. We in no way are implying that any of S&S Cycle's products are original equipment parts or that they are equivalent to the corresponding Harley-Davidson® part numbers.

## Follow Steps 1-7 To Prepare For Installation

1. Refer to proper H-D® manual for the model of bike you will be working on for the removal of existing oil pump.
2. Once you have successfully removed the cam plate and oil pump from the engine it will be necessary to measure the pinion shaft run out. Refer to manual for proper procedure and service limits.
3. If you will be reusing your existing cam plate, wash the cam plate and inspect the bearing surfaces. Refer to the manufacturers specifications for service wear limits. Inspect the pump mating surface for scoring; excessive scoring could adversely affect oil pressure.

**NOTE:** If your cam plate has non-serviceable oil galley plugs and has been exposed to debris from previous engine failure or other foreign material, it is almost impossible to effectively clean those passages. A new cam plate may be a better option.

4. Inspect or replace chain tension as needed. Refer to the H-D® manual for service wear limits.
5. Inspect the inner cam bearing, now is the time to replace this bearing while the engine is apart. Refer to manual for proper procedure and tools to use when replacing these bearings. Note: Full complement bearing is recommended.
6. Clean and flush your oil tank and oil lines. Any foreign matter that has accumulated in the oil tank will be sucked through the new oil pump. Oil pans with riveted-in baffle can be very hard to clean, it is very important to remove all debris from the pan. Also, when installing the S&S oil pump, the oil filter should be changed.
7. Remove pump from package and inspect pump for shipping damage. If there is any damage contact S&S immediately. Make sure pump has all parts shown in assembly drawing on last page.

## S&S Oil Pump Installation

1. **Make sure you have the proper oil pump for your engine.** S&S offers two styles of oil pumps, each specific to the engine type. For water cooled engines, the S&S oil pump kit pn is 310-0947. This pump is easily identified by a "W" machined into the front surface of the main pump body. For the oil cooled engines, the S&S oil pump kit pn is 310-0959. This pump is easily identified by an "O" machined into the front surface of the main pump body.
2. **Important:** If the oil pump is disassembled for cleaning, do not remove the pressure relieve valve assembly. This has been preset at the factory. Disassemble and wash all components of the oil pump. Make sure the pipe plug is installed and is flush or below the adjacent pump body surface.
3. The oil pump can be assembled into the cam chest one section at a time or as a complete unit, either method is acceptable as long as the mating sections fit tightly together.
4. **Individual section assembly method** - Install the flywheel scavenge port o-ring into the case (do not install the o-ring onto the pump). Put some assembly lube on the o-ring in order to make installing the return side pump housing easier.
5. Install the return side pump housing. Place your thumb on the lower left corner of the pump housing and push the housing into the o-ring.
6. Apply a liberal amount of assembly lube to the inner return rotor set and assemble into the return side pump housing. Make sure the relief cut side of the inner rotor goes toward the engine. **See Picture 1.**

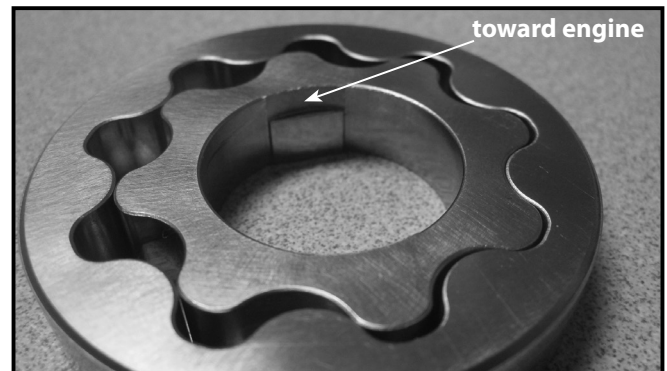

Picture 1

7. Install two 1/8" x 3/4" dowels into the return side pump housing.
8. Install divider plate over the dowel pins.
9. Locate the second return rotor set. Apply a liberal amount of assembly lube to the second return rotor set and place gear set into supply side pump body. Make sure the debris screen is firmly secured by the retaining clip. Carefully install the supply side pump into the cam chest and mated to the return side pump housing.
10. Place a straight edge across the oil pump body and make sure the face of the pump does not protrude past the cam support plate mating surface. **This check is critical to the final assembly. See Picture 2.**



**Picture 2**

**Note:** The oil supply passage o-ring will hold the plate slightly off the mounting surface until the support plates screws are fully tightened.

25. Turn the crankshaft so that the flat on the pinion shaft is facing straight up (12 o'clock position).
26. Apply a small amount of blue Loctite® to the cam support screws and the new oil pump screws. Make sure the flat washers are installed on the oil pump screws.
27. **Steps 28 thru 34 are critical to proper final assembly.**
28. Make sure the flat on the pinion shaft is facing straight up. **See picture 3** for correct orientation of pinion shaft.
29. Loosely install all cam support plate and oil pump screws but do not apply any torque.

11. If pump protrudes past mating surface check to see that the pump is installed all the way into the scavenge port o-ring.
12. Apply a liberal amount of assembly lube to the outer feed rotor set and install into the supply side pump body. Be sure these gears do not protrude past the front face of the pump.
13. Skip to step 21.
14. **Complete pump assembly method** - Thoroughly clean all components of the oil pump.
15. Assemble the pump according to the diagram in the back of these instructions. Apply as much assembly lube as possible to all the rotor sets. Align all of the inner rotor flats vertical (12 and 6 o'clock position). Make sure the inner return rotor set is installed with the relief cut toward the engine. **See Picture 1** and the appropriate exploded view in the back of these instructions.
16. Install the flywheel scavenge port o-ring into the case (do not install the o-ring onto the pump). Put some assembly lube on the o-ring in order to make installing the return side pump housing easier.
17. With the flats of the pinions shaft vertical (12 and 6 o'clock position), gently slide the oil pump assembly over the pinion shaft. It may be necessary to rock the crankshaft back and forth to allow all the rotors to properly align.
18. Place your thumb on the lower left corner of the pump housing and push the housing into the o-ring.
19. Place a straight edge across the oil pump body and make sure the face of the pump does not protrude past the cam support plate mating surface. **This check is critical to the final assembly. See Picture 2.**
20. If pump protrudes past mating surface check to see that the pump is installed all the way into the scavenge port o-ring.
21. Prepare the camshaft for assembly by thoroughly cleaning. Apply assembly lube to the inner bearing surface and install into the engine.
22. Apply assembly lube to a new o-ring and install into the oil supply passage in the crankcase.
23. Thoroughly clean and dry the cam support plate. Apply assembly lube to the pinion shaft and camshaft bearing surfaces.
24. Install the cam support plate onto the pinion shaft and camshaft. Make sure the support plate fully contacts the mounting surfaces of the engine case and the dowel is engaged into the mounting hole.



**Picture 3: Cam Support Plate Screws (1-6) and Oil Pump Screws (A, B, C, D)**

30. Snug the oil pump screws A, B, C and D but do not torque.
31. Snug the cam support plate screws 1, 2, 3, 4, 5, and 6 but do not torque.
32. Torque screws 1, 2, 3, 4, 5, and 6 in order to 90-120 in\*lbs. **See Picture 3a.**



**Picture 3a: Cam Plate Screws-Torque According to Step 32**

33. Rotate the crankshaft two complete revolutions with the flat on the pinion shaft facing straight up (12 o'clock position) when done.
34. Torque the oil pump screws A, B, C, and D in that order to 90-120 in\*lbs. **See Picture 3b.**



**Picture 3b: Oil Pump Screws-Torque According to Step 34**

35. Rotate the crankshaft through at least 2 revolutions to make sure binding does not occur in the oil pump. If binding does occur, loosen the oil pump and cam support plate screws and go through the installation procedure starting at Step 28.
36. Reinstall all remaining components according to the proper service manual or installation instructions.

#### **Oil Pressure:**

The pressure relief valve on the S&S oil pump has been set at the factory to relieve at approximately 45 psi.

**Important:** If changes are made to the pressure relief setting, use a caliper to measure the distance from the end of the pressure relief screw to the surface of the oil pump body and record this dimension for future reference.

The pressure relief valve is designed to keep the pump from building excessive oil pressure at high RPMs. Resist the temptation to turn in the screw in order to raise the low rpm oil pressure. If your engine has no oil pressure at idle, turning the pressure relief screw in more will normally not help this condition as this pressure will be below the operation point of the pressure relief valve. If you do adjust the pressure relief valve to something other than the factory setting, we recommend not tuning the adjuster more than ½ turn at a time. One half turn of the screw will move the adjuster .025" which typically changes the oil pressure approximately 5psi. There are other factors which will affect your oil pressure, the biggest influences being oil temperature.

**Replacement Parts:**

- 1. Dowel pin, 0.125"x0.750", 2 Pack ..... **500-0967**
- 2. Pressure Relief Valve Assembly ..... **500-0949**
- 3. Stainless Steel Mesh Screen (2) ..... **310-0546**
- 4. Rotor Set, Oil Pump, Cam Chest Scavenge ..... **310-1092**
- 5. Oil Pump Housing, Return Side ..... **N/A**
- 6. Oil Pump Housing, Supply Side,  
Oil Cooled ..... **N/A**
- Oil Pump Housing, Supply Side  
Water Cooled ..... **N/A**
- 7. Divider Plate ..... **310-0948**
- 8a. Rotor Set, Oil Pump Feed Gear (Oil-Cooled models) . . . . **310-0955**
- 8b. Rotor Set, Oil Pump, Feed Gear (Water-Cooled models) . . **310-1048**
- 9. Rotor Set, Oil Pump, Flywheel Scavenge ..... **310-1048**
- 10. 1/4" Pipe Plug 5 Pack ..... **500-0969**
- 11. Retaining Ring 5 Pack ..... **500-0968**
- 12. Magnet, .250" x .500" ..... **N/A**

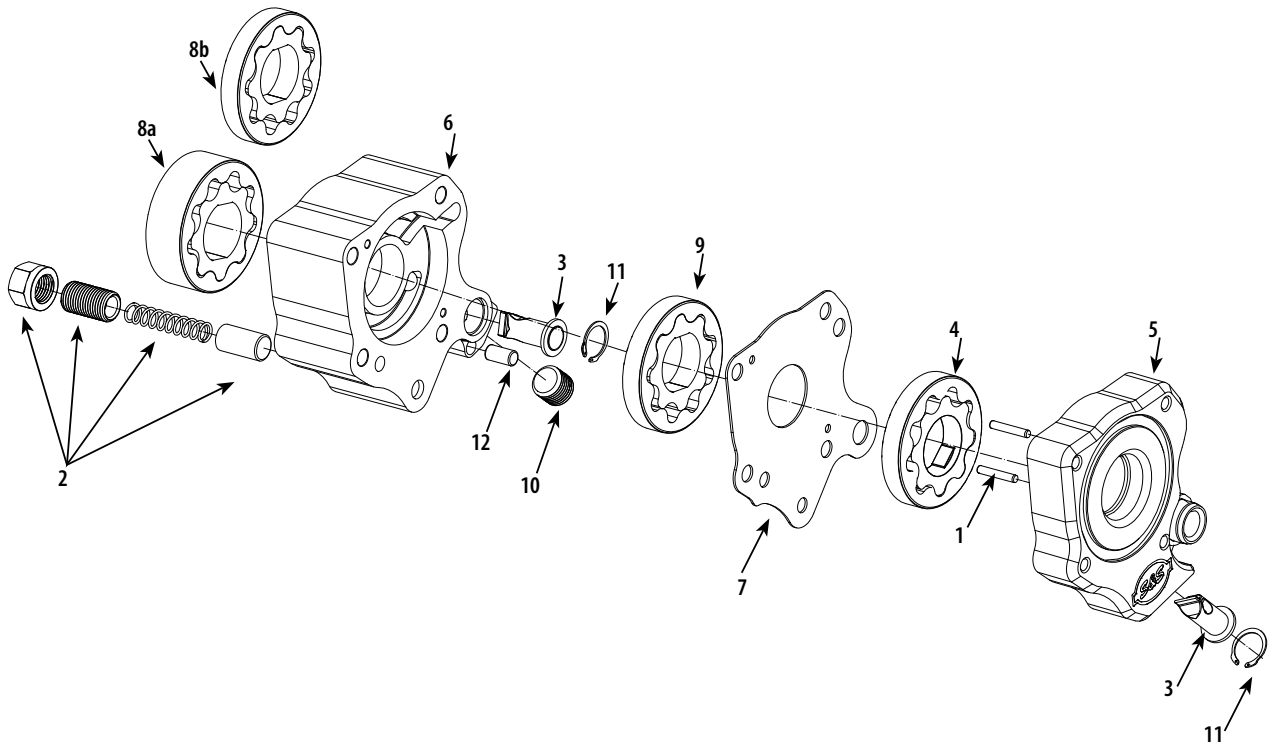

Instruction 510-0582

08-10-18

Version 3

© 2018

by S&S® Cycle, Inc.

All rights reserved.

Printed in the U.S.A.

**S&S® Cycle, Inc.**

14025 Cty Hwy G  
Viola, Wisconsin 54664

Phone: 608-627-1497

Technical Service Email: [sstech@sscycycle.com](mailto:sstech@sscycycle.com)

Website: [www.sscycycle.com](http://www.sscycycle.com)



## Installation Instructions: Cam Support Plate for 2017-up M8 Models

### DISCLAIMER:

Many S&S parts are designed for high performance, closed course, racing applications and are intended for the very experienced rider only. The installation of S&S parts may void or adversely affect your factory warranty. In addition such installation and use may violate certain federal, state, and local laws, rules and ordinances as well as other laws when used on motor vehicles used on public highways. Always check federal, state, and local laws before modifying your motorcycle. It is the sole and exclusive responsibility of the user to determine the suitability of the product for his or her use, and the user shall assume all legal, personal injury risk and liability and all other obligations, duties, and risks associated therewith.

### SAFE INSTALLATION AND OPERATION RULES:

Before installing your new S&S part, it is your responsibility to read and follow the installation and maintenance procedures in these instructions and follow the basic rules below for your personal safety.

- Gasoline is extremely flammable and explosive under certain conditions and toxic when breathed. Do not smoke. Perform installation in a well ventilated area away from open flames or sparks.
- If motorcycle has been running, wait until engine and exhaust pipes have cooled down to avoid getting burned before performing any installation steps.
- Before performing any installation steps, disconnect battery to eliminate potential sparks and inadvertent engagement of starter while working on electrical components.
- Read instructions thoroughly and carefully so all procedures are completely understood before performing any installation steps. Contact S&S with any questions you may have if any steps are unclear or any abnormalities occur during installation or operation of motorcycle with an S&S part on it.
- Consult an appropriate service manual for your motorcycle for correct disassembly and reassembly procedures for any parts that need to be removed to facilitate installation.
- Use good judgment when performing installation and operating motorcycle. Good judgment begins with a clear head. Don't let alcohol, drugs or fatigue impair your judgment. Start installation when you are fresh.
- Be sure all federal, state and local laws are obeyed with the installation.
- For optimum performance and safety and to minimize potential damage to carb or other components, use all mounting hardware that is provided and follow all installation instructions.
- Motorcycle exhaust fumes are toxic and poisonous and must not be breathed. Run motorcycle in a well ventilated area where fumes can dissipate.

### IMPORTANT NOTICE:

Statements in this instruction sheet preceded by the following words are of special significance.



#### WARNING

Means there is the possibility of injury to yourself or others.



#### CAUTION

Means there is the possibility of damage to the part or motorcycle.

#### NOTE

*Other information of particular importance has been placed in italic type.*

*S&S recommends you take special notice of these items.*

### WARRANTY:

All S&S parts are guaranteed to the original purchaser to be free of manufacturing defects in materials and workmanship for a period of twelve (12) months from the date of purchase. Merchandise that fails to conform to these conditions will be repaired or replaced at S&S's option if the parts are returned to us by the purchaser within the 12 month warranty period or within 10 days thereafter.

In the event warranty service is required, the original purchaser must call or write S&S immediately with the problem. Some problems can be rectified by a telephone call and need no further course of action.

A part that is suspect of being defective must not be replaced by a Dealer without prior authorization from S&S. If it is deemed necessary for S&S to make an evaluation to determine whether the part was defective, a return authorization number must be obtained from S&S. The parts must be packaged properly so as to not cause further damage and be returned prepaid to S&S with a copy of the original invoice of purchase and a detailed letter outlining the nature of the problem, how the part was used and the circumstances at the time of failure. If after an evaluation has been made by S&S and the part was found to be defective, repair, replacement or refund will be granted.

### ADDITIONAL WARRANTY PROVISIONS:

- (1) S&S shall have no obligation in the event an S&S part is modified by any other person or organization.
- (2) S&S shall have no obligation if an S&S part becomes defective in whole or in part as a result of improper installation, improper maintenance, improper use, abnormal operation, or any other misuse or mistreatment of the S&S part.
- (3) S&S shall not be liable for any consequential or incidental damages resulting from the failure of an S&S part, the breach of any warranties, the failure to deliver, delay in delivery, delivery in non-conforming condition, or for any other breach of contract or duty between S&S and a customer.

## NOTES:

- The S&S M8 cam support plate is machined from high strength billet aluminum. This material and manufacturing method provide strength and dimensional stability over aluminum castings. In addition, billet aluminum does not have voids, inclusions and other structural defects associated with aluminum castings.
- Variations in color of the anodized finish is not considered a defect. Despite the variations in color, the ability of the anodized coating to protect the part is unchanged. You may install these products with confidence, knowing that they will function as they are intended.
- Possible failure may result if thread locking compound is not applied to the cam drive sprocket flange bolts. Always prepare threads according to the instructions on the container.
- All reference to Harley-Davidson® part numbers is for identification purposes only. In no way is it implied that any S&S Cycle products are original equipment parts or that they are equivalent to corresponding Harley-Davidson® part numbers.
- Installation of the S&S Cycle cam support plate requires the use of special tools and repair manuals for the model of bike you will be working on. Attempting the installation without the proper tools and manuals will be difficult. Damage can result which will not be covered under warranty.

**SPECIAL TOOLS REQUIRED** (only needed if inner cam bearing will be replaced)

- Camshaft Needle Bearing Remover/Installer, HD® Part Number: 42325-4
- Crankshaft/Camshaft Sprocket Locking Tool, HD Part Number 42314

## Pre-Cautions:

- Clean and flush the oil pan and oil lines to prevent foreign material from being sucked through the oil pump and through the new cam support plate. The oil filter should also be changed when installation is complete.
- **NOTE:** If debris is suspected in the oil pan, it is highly recommended to remove the oil pan in order to thoroughly clean it out.

## Installation

1. Unpackaged the cam support plate kit and verify the all the threaded plugs have been installed. Confirm that the kit contains a new o-ring kit and hydraulic tensioner block off plate kit.
2. Prepare the cam support plate for assembly by cleaning the plate with soap and water or parts cleaner. Be sure to thoroughly dry the internal passages.
3. Before starting work on the motorcycle, disconnect the negative terminal of the battery to eliminate the potential for sparks and inadvertent engagement of the starter while working on the motorcycle.
4. Refer to the HD® service manual for the model of bike you will be working on for proper removal of all components. Save the original fasteners to be reused when the the S&S cam support plate is installed.
5. Remove the cam support plate and oil pump from the engine according to the HD® service manual and measure flywheel pinion shaft run out. Refer to the manual for proper procedure. S&S recommends no more than 0.005" of total indicated runout on the pinion shaft while checked in the cases.
6. If you intend to reuse the existing oil pump, it must be thoroughly cleaned and inspected to ensure that it is serviceable. Refer to the manufacturer service wear limits for the gears and pump body bores. If the areas under the pump gears are scored this will adversely affect the ability of the pump to supply and/or return oil.

7. Inspect the inner cam bearing, now is the time to replace this bearing while the engine is apart. It is highly recommended to replace the bearing with a full complement bearing, S&S Cycle pn 31-4199-S. Refer to the service manual for proper procedure to replace this bearing.

**NOTE:** Use as much of the provided assembly lube as possible on all of the oil pump rotors during assembly. This will aid in priming the oil pump upon start up.

8. Install a new o-ring on the flywheel cavity suction side of the oil pump and re-install the pump into the cam chest. Use a straight edge to confirm that the outer face of the oil pump is recessed slightly from the cam plate mounting surface. (**See Picture 1**). This is done to ensure that there will be no binding in the oil pump when it is tightened to the cam plate.



**Picture 1**

9. Install a new o-ring into the oil supply port of the engine case. **See Picture 2.**

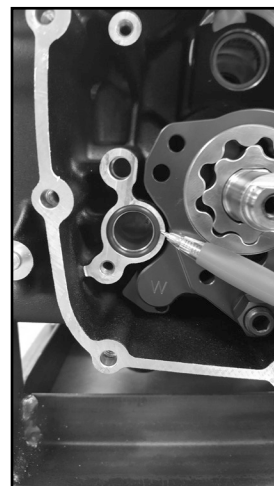

**Picture 2**

10. Apply assembly lube to the rollers of the inner cam bearing and to the cam bearing surface and lobes of the camshaft. Insert the camshaft into the inner cam bearing.
11. Apply assembly lube to the outer cam bearing surface of the camshaft and to the pinion shaft.
12. Install the cam support plate onto the pinion shaft and camshaft. Make sure the support plate fully contacts the mounting surfaces of the engine case and the dowel is engaged into the mounting hole.

**NOTE:** The oil supply passage o-ring will hold the plate slightly off the mounting surface until the support plates screws are fully tightened.

13. Turn the crankshaft so that the flat on the pinion shaft is facing straight up (12 o'clock position).
14. Apply a small amount of blue threadlocker to the cam support screws and the new oil pump screws. Make sure the flat washers are installed on the oil pump screws.
15. **Steps 16 thru 22 are critical to proper final assembly.**
16. Make sure the flat on the pinion shaft is facing straight up. **See Picture 3** for correct orientation of pinion shaft.
17. Loosely install all cam support plate and oil pump screws but do not apply any torque.



**Picture 3: Cam Support Plate Screws (1-6) and Oil Pump Screws (A, B, C, D)**

18. Snug the oil pump screws A, B, C and D but do not torque.
19. Snug the cam support plate screws 1, 2, 3, 4, 5, and 6 but do not torque.
20. Torque screws 1, 2, 3, 4, 5, and 6 in order to 90-120 in\*lbs. **See picture 3a.**



**Picture 3a: Cam Plate Screws-Torque According to Step 20**

21. Rotate the crankshaft two complete revolutions with the flat on the pinion shaft facing straight up (12 o'clock position) when done.
22. Torque the oil pump screws A, B, C, and D in that order to 90-120 in\*lbs.



**Picture 3b: Oil Pump Screws-Torque According to Step 22**

23. Rotate the crankshaft to make sure binding does not occur in the oil pump. If binding occurs, loosen the oil pump and cam support plate screws and go through the installation procedure starting at step 17.
24. Install the cam drive components (chain or gear) according to the manufacturer's installation procedures.



25. Apply blue threadlocker to the cam cover screws, install the cam cover, gasket and screws. Tighten the cam cover screws to 120 in-lbs in the sequence shown **(See Picture 4)**.

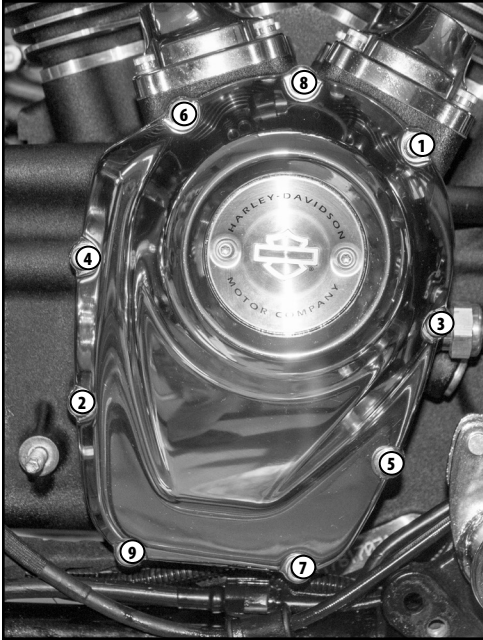

**Picture 4**

26. Reinstall the pushrods according to the manufacturer's installation procedure.
27. Reinstall exhaust system and right side floor board or foot peg.

### Cam Support Plate Replacement Parts

- 1. Cam support plate ..... **N/A**
- 2. 1/8" pipe plug, 10 pack ..... **50-1015**
- 3. 1/4" pipe plug, ..... **50-8330A**
- 4. M8 cam support plate oil supply plug kit ..... **500-0966**
- 5. Hydraulic tensioner block off plate kit (*not pictured*) ..... **310-0962**
- 6. O-ring kit (*not pictured*) ..... **500-0850**

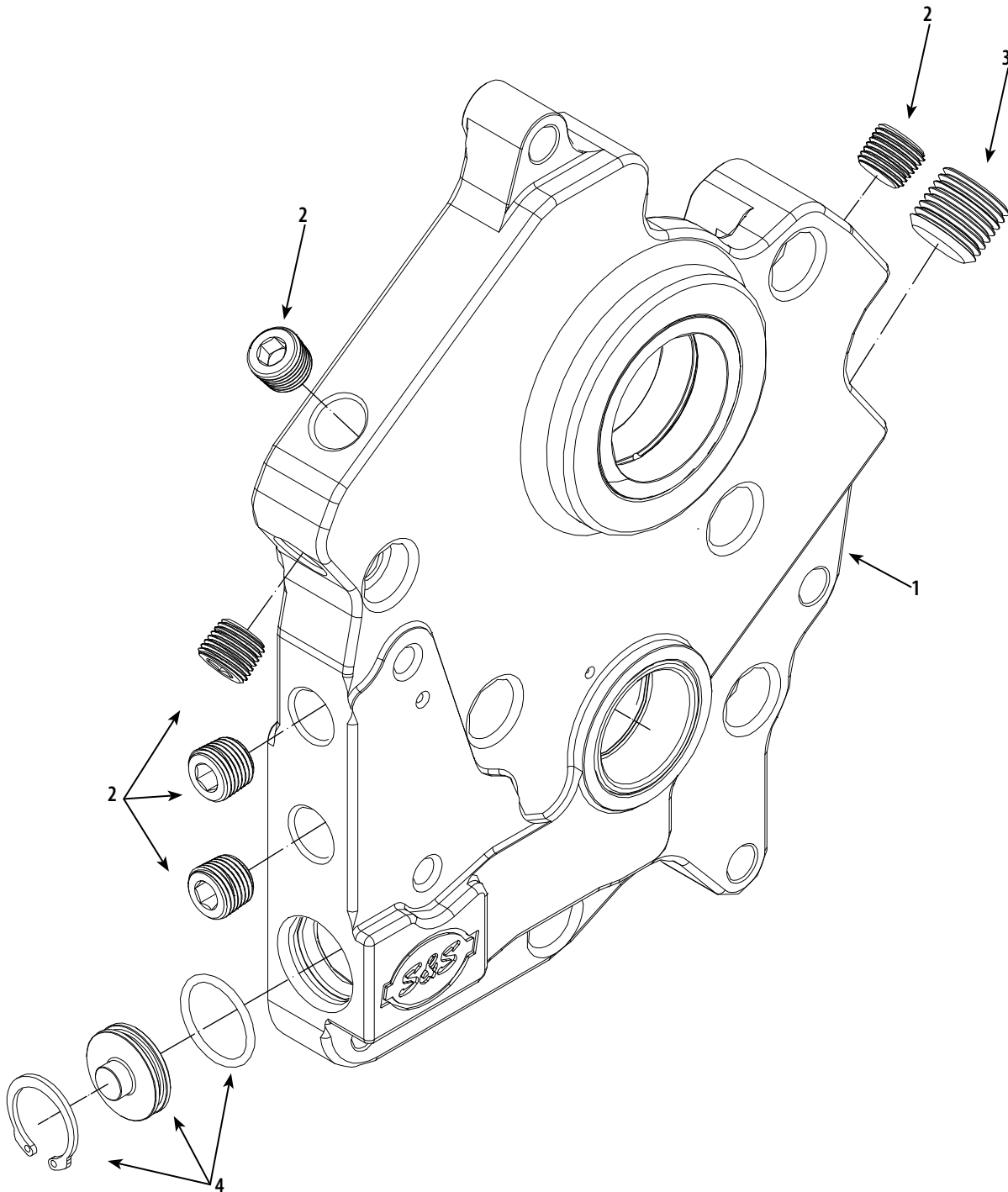

Instruction 106-6046

11-15-17

Version 3

Copyright © 2012, 2015, 2016, 2017

by S&S® Cycle, Inc.

All rights reserved.

Printed in the U.S.A.

**S&S® Cycle, Inc.**

14025 Cty Hwy G  
Viola, Wisconsin 54664

Phone: 608-627-1497 • Fax: 608-627-1488

Technical Service Phone: 608-627-TECH (8324)

Technical Service Email: [sstech@sscycycle.com](mailto:sstech@sscycycle.com)

Website: [www.sscycycle.com](http://www.sscycycle.com)



## Installation and Adjustment Instructions for S&S Adjustable Pushrods For Hydraulic Tappets

### DISCLAIMER:

Many S&S parts are designed for high performance, closed course, racing applications and are intended for the very experienced rider only. The installation of S&S parts may void or adversely affect your factory warranty. In addition such installation and use may violate certain federal, state, and local laws, rules and ordinances as well as other laws when used on motor vehicles used on public highways. Always check federal, state, and local laws before modifying your motorcycle. It is the sole and exclusive responsibility of the user to determine the suitability of the product for his or her use, and the user shall assume all legal, personal injury risk and liability and all other obligations, duties, and risks associated therewith.

\*Manufacturer declared emissions legal replacement part.

### SAFE INSTALLATION AND OPERATION RULES:

Before installing your new S&S part, it is your responsibility to read and follow the installation and maintenance procedures in these instructions and follow the basic rules below for your personal safety.

- Gasoline is extremely flammable and explosive under certain conditions and toxic when breathed. Do not smoke. Perform installation in a well ventilated area away from open flames or sparks.
- If motorcycle has been running, wait until engine and exhaust pipes have cooled down to avoid getting burned before performing any installation steps.
- Before performing any installation steps, disconnect battery to eliminate potential sparks and inadvertent engagement of starter while working on electrical components.
- Read instructions thoroughly and carefully so all procedures are completely understood before performing any installation steps. Contact S&S with any questions you may have if any steps are unclear or any abnormalities occur during installation or operation of motorcycle with an S&S part on it.
- Consult an appropriate service manual for your motorcycle for correct disassembly and reassembly procedures for any parts that need to be removed to facilitate installation.
- Use good judgment when performing installation and operating motorcycle. Good judgment begins with a clear head. Don't let alcohol, drugs or fatigue impair your judgment. Start installation when you are fresh.
- Be sure all federal, state and local laws are obeyed with the installation.
- For optimum performance and safety and to minimize potential damage to components, use all mounting hardware that is provided and follow all installation instructions.
- Motorcycle exhaust fumes are toxic and poisonous and must not be breathed. Run motorcycle in a well ventilated area where fumes can dissipate.

### IMPORTANT NOTICE:

Statements in this instruction sheet preceded by the following words are of special significance.



**WARNING**

Means there is the possibility of injury to yourself or others.



**CAUTION**

Means there is the possibility of damage to the part or motorcycle.

**NOTE**

*Other information of particular importance has been placed in italic type.*

*S&S recommends you take special notice of these items.*

### WARRANTY:

All S&S parts are guaranteed to the original purchaser to be free of manufacturing defects in materials and workmanship for a period of twelve (12) months from the date of purchase. Merchandise that fails to conform to these conditions will be repaired or replaced at S&S's option if the parts are returned to us by the purchaser within the 12 month warranty period or within 10 days thereafter.

In the event warranty service is required, the original purchaser must call or write S&S immediately with the problem. Some problems can be rectified by a telephone call and need no further course of action.

A part that is suspect of being defective must not be replaced by a Dealer without prior authorization from S&S. If it is deemed necessary for S&S to make an evaluation to determine whether the part was defective, a return authorization number must be obtained from S&S. The parts must be packaged properly so as to not cause further damage and be returned prepaid to S&S with a copy of the original invoice of purchase and a detailed letter outlining the nature of the problem, how the part was used and the circumstances at the time of failure. If after an evaluation has been made by S&S and the part was found to be defective, repair, replacement or refund will be granted.

### ADDITIONAL WARRANTY PROVISIONS:

- (1) S&S shall have no obligation in the event an S&S part is modified by any other person or organization.
- (2) S&S shall have no obligation if an S&S part becomes defective in whole or in part as a result of improper installation, improper maintenance, improper use, abnormal operation, or any other misuse or mistreatment of the S&S part.
- (3) S&S shall not be liable for any consequential or incidental damages resulting from the failure of an S&S part, the breach of any warranties, the failure to deliver, delay in delivery, delivery in non-conforming condition, or for any other breach of contract or duty between S&S and a customer.

## Introduction

S&S adjustable pushrods, for engines with late style hydraulic tappets, may be one of two types. See **Picture 1**. S&S Standard Adjustable Pushrods, which feature a threaded adjusting sleeve and a fixed adjusting screw, generally require the removal of the rocker covers and arms for installation or removal. S&S Quickee Pushrods have an adjusting screw that threads into the pushrod body, allowing the pushrod to collapse, becoming short enough to be installed and removed from an engine without disassembling the rocker covers. Quickee pushrods are also used in the S&S Valve Train Upgrade Kits for 1966-84 big twins.

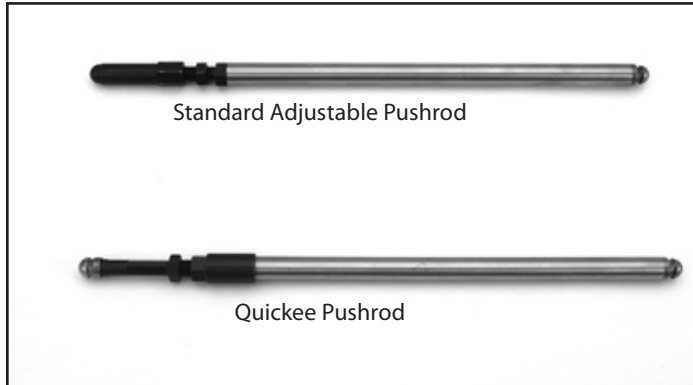

Picture 1

### NOTES:

- Pushrod installation and adjustments must be made when engine is cold. Read instructions thoroughly and follow all recommended steps and procedures.
- If S&S® Standard Adjustable pushrod kit contains four different length pushrods, the longest pushrod is for the front exhaust, next longest is the rear exhaust. Of the two shorter pushrods, the longer one is the front intake, the shortest pushrod is the rear intake. Pushrod kits for 1999–up big twin engines have two different lengths—short for the intakes, long for the exhausts. Pushrod kits for Sportster® models contain four identical pushrods.
- S&S Quickee Pushrods for Harley-Davidson® shovel and Evolution® engines contain two long and two short pushrods. Quickee pushrods for Sportster® models and 1999–up big twins are the same length.
- S&S adjustable pushrods have a thread pitch of 32 threads per inch. This means that one complete turn equals .031" of change in pushrod length and one flat is .005".
- Basic adjustment instructions are for installing S&S adjustable pushrods with the stock-style hydraulic lifters. If the S&S HL2T (Hydraulic Lifter Limiter Travel) kit has been installed in the tappets, pushrod adjustment must be done according to the HL2T instructions.
- To determine if HL2T kit has been installed in the tappets of an assembled engine, compress the hydraulic piston assembly by lengthening the pushrod four complete turns of the pushrod adjuster. After 20 minutes try to spin the pushrod between your fingers. If the pushrod can not be turned with finger pressure, an HL2T kit is installed in the lifters and the HL2T adjustment procedure must be followed. See Section C, Page 3.
- When adjusting Quickee Pushrods, count flats on the 6 sided female adjuster on the pushrod, not the 4 sided male adjusting screw.
- Quickee pushrods for 1966–'84 big twin engines must be used with the S&S hydraulic conversion kit which includes S&S hydraulic tappets and tappet guides. Pushrods with oil holes are for use with S&S rocker arms. Pushrods without oil holes are for stock rocker arms.

- S&S hydraulic lifters have .200" of hydraulic plunger travel. When adjusting pushrods, the plunger should be positioned near the center of its travel. This would be 4 turns or 24 flats which is equal to .125".



- Failure to follow recommended steps and procedures may result in damage to engine components.
- When installed and adjusted, S&S Quickee Pushrods must have a minimum thread engagement of .500" (Pushrod tube to Adjuster, not including the jam nut) or severe damage to the pushrod as well as your engine may occur.
- When adjustment is complete, the jam nut must have full thread engagement with the adjuster screw. If you do not have full engagement, the pushrod is not correct for the application or position.



Installing or adjusting pushrods while engine is hot could result in burns from contact with hot engine parts.

### Pushrod Installation

1. Remove pushrod cover clips and lift cover assemblies to view tappets.
2. Remove spark plugs and rotate engine until front piston is at the top of its stroke, with both front lifters at their lowest position (TDCC—top dead center compression).

NOTE: To ensure that the piston is at the correct position to remove pushrods, rotate the engine forward and watch the intake pushrod. The intake pushrods are the two closest to the center of the engine. Watch the intake pushrod rise and fall as the engine is rotated. When the intake pushrod is at its lowest position, the piston is on its compression stroke. Check to see if the piston is at TDC. If it isn't, rotate the engine a few more degrees to bring the piston to the top of the cylinder.

3. Remove front pushrods.
  - a. If installing standard adjustable pushrods, disassemble the rocker cover and rocker arm assembly, per the appropriate service manual.
  - b. If installing Quickee pushrods, stock pushrods may be cut out with a bolt cutter to save time. See NOTE and CAUTION below.

NOTE: Since S&S Quickee pushrods do not require rocker arm disassembly for installation, stock pushrods may be cut out of the engine to save time. S&S recommends that they be cut with a bolt cutter.



Do not cut pushrods with a saw, metal chips may enter engine and cause extensive damage not covered by warranty.



Make sure tappet is at lowest point of travel and pushrod is not under valve spring pressure before cutting pushrods. Sudden release of valve spring pressure may cause cut pushrods to fly out of motor, potentially causing serious injury.

- Clean and inspect the pushrod tubes. Replace all o-rings. Apply a light coat of engine oil to the o-rings. If using stock pushrod tubes and Quickee pushrods in an Evolution engine, the inner tube should be shortened to avoid contact with pushrod during operation. See **Picture 2**. Shorten the tube according to the following chart:

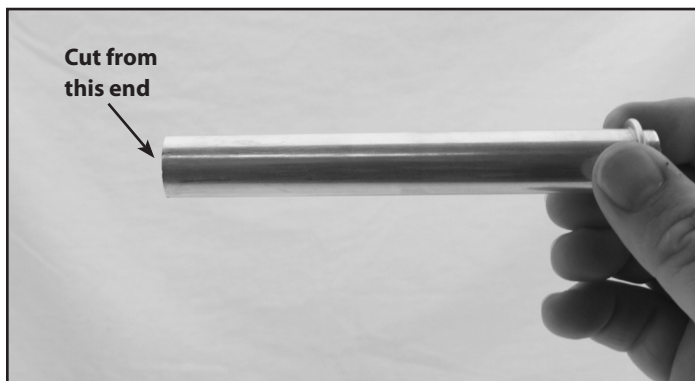

**Picture 2**

Displacement	Cylinder Length	Final Length of Inner Pushrod Tube
100	4.745	4"
88,107	5.375	4.75"
93,113	5.5	4.875"
80,89,96	5.55	4.875"
98	5.625	5"
103	5.75	5"

- Insert new pushrods through tube assemblies with the adjuster ends down, and install in appropriate positions.
- Reinstall rocker assemblies according to appropriate service manual procedures, if they were removed.

### Basic Pushrod Adjustment

- Holding pushrod so the top ball end is in the rocker arm cup, extend adjusting screw until the bottom ball end just contacts the tappet cup. (See note on M8 applications) Compress hydraulic unit in exhaust lifter an additional 4 complete turns (24 flats) and tighten locknut. Allow sufficient time for lifter to bleed down (20 to 30 minutes) before adjusting intake pushrod. Pushrods must spin freely with fingers..

*Note: With Standard Adjustable Pushrods tighten nut against adjuster sleeve. With S&S Quickee Pushrods, tighten nut against the pushrod body.*

- Repeat procedure for Intake pushrod.

*NOTE: If pushrods can not be turned between fingers after 20 minutes, tappets contains S&S HL2T spacers. Detailed instructions for the HL2T kit are presented in the next section.*



**Failure to allow hydraulic unit to bleed down before rotating engine or adjusting the other pushrod could result in valve-to-valve contact and serious valve train damage. Lifters are bled down when pushrod can be turned with fingertips.**

- Bring rear piston to Top Dead Center Compression (TDCC) and repeat above procedures for rear cylinder.

- Replace spark plugs and pushrod tube clips. Start motorcycle and check for leaks.

### Notes For Sportster® Models

- In order to access the pushrod adjuster screws in 1991 and later Harley-Davidson® Sportster® and Buell® models, it will be necessary to use pushrod cover assembly kit for 1986–'90 Sportster® models, S&S part 93-4038, and the appropriate length pushrod cover keepers. 1991-'03 models will also require pushrod cover adapter kit, S&S part 33-5355.*
- On 1991 and later models, it is necessary to disassemble the rocker arm/rocker box to remove the stock one piece pushrod cover.*

### Notes For Twin Cam 88®, 96™, 103™ and Milwaukee Eight® Engines

- S&S pushrod kits for the Twin Cam 88®, 96™, 103™ and Milwaukee Eight® engines are available as a kit containing pushrods only, however, it will be necessary to use S&S pushrod covers, or similar aftermarket product, in order to be able to access the adjuster units on the pushrods. S&S offers kits for stock height 1999–up big twin engines that contain the four adjustable pushrods, pushrod tube set, gaskets and o-rings for a complete assembly.*
- The tappet covers on Milwaukee-Eight engines are quite tall, and care should be taken not to allow the lock-nut to drop to the bottom of the adjuster when installing Quickee pushrods. It is suggested that the 1/4" wrench be applied to the adjuster screw with the nut above it until the adjuster is screwed out of the pushrod, and the nut can be threaded onto the adjuster screw.*
- If equipped with S&S Easy Start compression release cams, you must use extra care when adjusting pushrods. Because the decompression lobe is near TDC, it is possible to adjust the pushrod while the tappet is on the lobe if it is not exactly at TDC. This will cause incorrect exhaust pushrod adjustment. To verify correct position, you can rotate the engine in the forward direction and feel for the exhaust tappet to slightly lift (about .030") and set back down on the base circle. This is the proper point to adjust the pushrods.*
- Once the stock non-adjustable pushrods have been removed, S&S Standard pushrod kits for the Twin Cam 88®, 96™, and 103™ may be installed and removed from the engine without removing the rocker covers. Remove fasteners from tappet covers. Turn the adjusters to make the pushrods as short as possible. Hold the pushrods up against the rocker arm cups and swing pushrods and tappet covers out as an assembly. To install, reverse the process. Insert pushrods through pushrod cover assemblies. Install intake and exhaust pushrod assemblies, along with the tappet cover and new gasket, into position in front cylinder. See **Picture 3**.*



**Picture 3**

## Adjusting Pushrods With S&S HL<sub>2</sub>T Limited Travel Kit Installed

### NOTES:

- The S&S HL<sub>2</sub>T kit is designed to limit the travel of the hydraulic lifter making it impossible for the lifter to collapse. Stronger valve springs are often used to avoid valve float at high rpm. The HL<sub>2</sub>T kit prevents high valve spring force from collapsing lifters. With the HL<sub>2</sub>T kit installed, stock hydraulic lifters work like solid lifters at high rpm, while retaining normal hydraulic function for minimal noise and maintenance under normal conditions. Adjustable pushrods must be used with the HL<sub>2</sub>T kit.
- S&S Limited Travel Kit 33-5338 fits all S&S tappets and all Harley-Davidson® replacement tappets for 1999-'17 big twins (18538-99C & 18572-13) and 1991-'17 Sportster® models (18526-89A & 18538-99C).
- S&S Limited Travel kit does not fit Harley-Davidson® replacement tappets (18523-86B) for 1984-'99 big twins and 1986-'90 Sportster® models.
- If using aftermarket tappets, consult the manufacturer to determine compatibility. See Limited Travel washer dimensions below.

KIT	OD	ID
33-5338	.605 OD	.440 ID

### HL<sub>2</sub>T Kit Installation

1. If tappets are installed in the engine, it is recommended that they be removed. Be sure that each tappet is kept with its original tappet block and bore.

*NOTE: This procedure is the preferred method of installation. However, kit can be installed without removing lifters from engine.*

2. Remove hydraulic piston retaining wire clip from one assembly at a time.



### Be careful not to deform wire clip during disassembly.

4. Completely disassemble tappet removing all parts.
5. Thoroughly clean all parts including tappet body. Remove any oil which might prevent hydraulic unit from fully collapsing during adjustment.
6. Insert one spacer from S&S HL<sub>2</sub>T kit in tappet body.
7. Reassemble tappet in reverse order making sure original parts are returned to their original positions. See **Picture 4**.

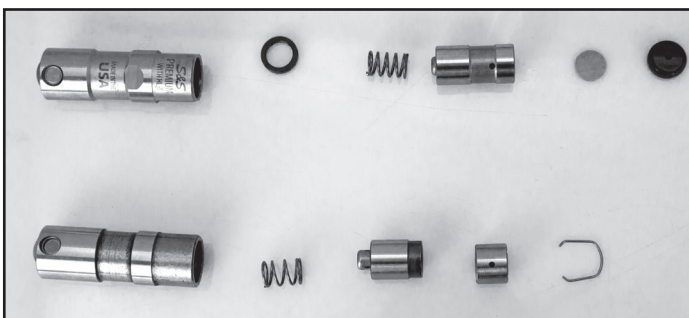

Picture 4

8. Replace wire retaining clip in tappet body.
9. Put tappet back in original tappet bore.

10. Repeat Steps 2 through 8 for three remaining tappets.

11. Reassemble engine with modified tappets.

12. Adjust pushrods.

*NOTE: In all cases engine must be cold and lifter must be at lowest point of travel for pushrod adjustment.*

- a. Remove sparkplugs.
- b. Remove spark plugs and rotate engine until front piston is at the top of its stroke, with both front lifters at their lowest position (TDCC – top dead center, compression).

*NOTE: To ensure that the cylinder is at the correct position to adjust pushrods, rotate the engine forward and watch the intake pushrod. The intake pushrods are the two closest to the center of the engine. Watch the intake pushrod rise and fall as the engine is rotated. When the intake pushrod is at its lowest position, the cylinder is on its compression stroke. Check to see if the piston is at TDC. If it isn't, rotate the engine a few more degrees to bring the piston to the top of the cylinder.*

- c. Extend one of the front pushrods until it contacts the hydraulic piston assembly in the lifter body, then extend pushrod an additional four complete turns, until piston assembly is in contact with HL<sub>2</sub>T spacer and the valve is lifted off of its seat. If tappets contain oil, as when pushrods are readjusted after engine has been run, or if all oil was not removed during installation, allow at least 20–30 minutes for piston assembly to bleed down. If pushrod can be turned between the fingers, tappet piston is not in contact with HL<sub>2</sub>T spacer. Lengthen pushrod one additional turn and test again after 20 minutes.
- d. If pushrod can not be turned between the fingers, loosen pushrod adjustment until pushrod can be rotated with the fingers with slight drag. Continue loosening (shortening) pushrod one full turn (6 flats).

*NOTE: Shortening adjuster an additional six flats or one full turn from zero lash often results in quieter valve train operation. This provides additional travel for the hydraulic piston assembly, which can improve the ability of the hydraulic unit to maintain zero lash under normal operating conditions.*

- e. Tighten lock nut.
- f. Repeat steps c, d, and e for the other front pushrod.
- g. Repeat above procedures for rear cylinder, this time bringing rear piston to TDCC (top dead center compression).
- h. Replace spark plugs and install pushrod clips.

*NOTE: Perform this operation on one cylinder at a time. Do not turn engine until pushrod adjustment is complete, and pushrod can be spun with fingers.*



Instruction 510-0575

12-04-17

Version 1

Copyright © 2017

by S&S® Cycle, Inc.

All rights reserved.

Printed in the U.S.A.

**S&S® Cycle, Inc.**

14025 Cty Hwy G

Viola, Wisconsin 54664

Phone: 608-627-1497 • Fax: 608-627-1488

Technical Service Phone: 608-627-TECH (8324)

Technical Service Email: [sstech@sscycycle.com](mailto:sstech@sscycycle.com)

Website: [www.sscycycle.com](http://www.sscycycle.com)



## Installation Instructions: S&S Tappet Cuffs for 2017-2018 Harley-Davidson® Milwaukee-Eight® Engines

### DISCLAIMER:

Many S&S parts are designed for high performance, closed course, racing applications and are intended for the very experienced rider only. The installation of S&S parts may void or adversely affect your factory warranty. In addition such installation and use may violate certain federal, state, and local laws, rules and ordinances as well as other laws when used on motor vehicles used on public highways. Always check federal, state, and local laws before modifying your motorcycle. It is the sole and exclusive responsibility of the user to determine the suitability of the product for his or her use, and the user shall assume all legal, personal injury risk and liability and all other obligations, duties, and risks associated therewith.

### SAFE INSTALLATION AND OPERATION RULES:

Before installing your new S&S part, it is your responsibility to read and follow the installation and maintenance procedures in these instructions and follow the basic rules below for your personal safety.

- Gasoline is extremely flammable and explosive under certain conditions and toxic when breathed. Do not smoke. Perform installation in a well ventilated area away from open flames or sparks.
- If motorcycle has been running, wait until engine and exhaust pipes have cooled down to avoid getting burned before performing any installation steps.
- Before performing any installation steps, disconnect battery to eliminate potential sparks and inadvertent engagement of starter while working on electrical components.
- Read instructions thoroughly and carefully so all procedures are completely understood before performing any installation steps. Contact S&S with any questions you may have if any steps are unclear or any abnormalities occur during installation or operation of motorcycle with an S&S part on it.
- Consult an appropriate service manual for your motorcycle for correct disassembly and reassembly procedures for any parts that need to be removed to facilitate installation.
- Use good judgment when performing installation and operating motorcycle. Good judgment begins with a clear head. Don't let alcohol, drugs or fatigue impair your judgment. Start installation when you are fresh.
- Be sure all federal, state and local laws are obeyed with the installation.
- For optimum performance and safety and to minimize potential damage to carb or other components, use all mounting hardware that is provided and follow all installation instructions.
- Motorcycle exhaust fumes are toxic and poisonous and must not be breathed. Run motorcycle in a well ventilated area where fumes can dissipate.

### IMPORTANT NOTICE:

Statements in this instruction sheet preceded by the following words are of special significance.



**WARNING**

Means there is the possibility of injury to yourself or others.



**CAUTION**

Means there is the possibility of damage to the part or motorcycle.

**NOTE**

*Other information of particular importance has been placed in italic type.*

*S&S recommends you take special notice of these items.*

### WARRANTY:

All S&S parts are guaranteed to the original purchaser to be free of manufacturing defects in materials and workmanship for a period of twelve (12) months from the date of purchase. Merchandise that fails to conform to these conditions will be repaired or replaced at S&S's option if the parts are returned to us by the purchaser within the 12 month warranty period or within 10 days thereafter.

In the event warranty service is required, the original purchaser must call or write S&S immediately with the problem. Some problems can be rectified by a telephone call and need no further course of action.

A part that is suspect of being defective must not be replaced by a Dealer without prior authorization from S&S. If it is deemed necessary for S&S to make an evaluation to determine whether the part was defective, a return authorization number must be obtained from S&S. The parts must be packaged properly so as to not cause further damage and be returned prepaid to S&S with a copy of the original invoice of purchase and a detailed letter outlining the nature of the problem, how the part was used and the circumstances at the time of failure. If after an evaluation has been made by S&S and the part was found to be defective, repair, replacement or refund will be granted.

### ADDITIONAL WARRANTY PROVISIONS:

- (1) S&S shall have no obligation in the event an S&S part is modified by any other person or organization.
- (2) S&S shall have no obligation if an S&S part becomes defective in whole or in part as a result of improper installation, improper maintenance, improper use, abnormal operation, or any other misuse or mistreatment of the S&S part.
- (3) S&S shall not be liable for any consequential or incidental damages resulting from the failure of an S&S part, the breach of any warranties, the failure to deliver, delay in delivery, delivery in non-conforming condition, or for any other breach of contract or duty between S&S and a customer.

## Installation

1. Mount motorcycle on a lift and secure with straps. Remove the battery ground cable.

*NOTE – If you wish to reuse the stock pushrods, follow the procedure outlined in the factory service manual for pushrod removal. However, due to the amount of labor involved in that procedure, we recommend that the stock pushrods be cut out and replaced with S&S Quicke adjustable pushrods. If removing the pushrods per the factory procedure skip, to step 7.*

2. Remove the spark plugs, and Jack the rear end of the motorcycle up so the rear wheel is off the work surface. Shift the transmission into high gear. The rear wheel will be used to turn the engine.
3. Remove the pushrod cover keepers, and slide the pushrod covers up so the pushrods are visible.
4. Turn the rear wheel until either cylinder is at TDC compression. Both valves will be closed, and both tappets will be at the lowest point of travel. There should be no valve spring force on the pushrods and it should be possible to turn them with your fingers.
5. Use a bolt cutter to cut the pushrods, and remove them from the engine. If using the S&S Quicke pushrod and cover kit, save the stock pushrod cover caps, springs and washers for reuse.



**Do not cut pushrods with a saw or grinder. Metal particles will be generated which may cause serious engine damage that is not covered under warranty.**



**Do not attempt to cut pushrods while they are under tension from the valve springs. Pushrod segments may be forcibly ejected from the engine, possibly causing personal injury.**

6. Repeat steps 4 and 5 for the other cylinder.
7. Using a 3/16" Allen driver, remove the four screws holding the tappet covers, and remove the covers. Save the screws and gaskets for reuse.
8. Using a 3/8" hex socket, remove the screws securing the stock tappet anti rotation brackets, and remove the brackets.

*NOTE – Tappets may easily be replaced at this time if desired.*

9. Inspect tappet cover gasket and pushrod cover o-rings for damage. Replace as needed. Clean stock parts to be reinstalled with solvent.
10. S&S Tappet Cuffs are marked F and R for front and rear. Install cuffs in the correct position.
11. Apply blue threadlocker to the stock retaining screws and install screws.
12. Starting with the rear cylinder, insert a .002" feeler gauge between the tappet and cuff to prevent the cuff from rotating and binding on the tappet when the screw is tightened as shown in **Picture 1**.



**Picture 1**

13. Tighten the screw to 100 in-lb and remove the feeler gauge. Repeat for front cylinder.
  14. Turn engine two complete rotations to ensure that the tappets move freely and do not contact the cuff or bind at any point.
  15. Reinstall the tappet covers and gaskets.
  16. Apply blue threadlocker to the tappet cover screws and install screws.
  17. Tighten tappet cover screws to 140 in-lb.
  18. If reusing stock pushrods, reinstall pushrods and covers, and reassemble pushrods tubes and rocker covers per factory procedure. If using S&S Quicke pushrods, skip to the next step.
  19. If necessary, turn the rear wheel until either of the cylinders is at TDC compression. Both tappets will be at the lowest point of travel.
- NOTE - tappet covers on M8 engines are quite tall and it can be difficult to see position of the tappets. Placing the short ends of cut off stock pushrods in tappet cover holes makes it easy to observe tappet movement.*
20. Install new o-ring seals in tappet cover and rocker cover. Assemble pushrod covers using stock pushrod cover caps, springs, and washers, and the o-ring provided in kit.
  21. Install Quicke pushrods and S&S pushrod covers according to instructions provided in the kit.
- NOTES*
- S&S or similar pushrod covers must be used with Quicke Pushrods. Stock covers are too short to allow for pushrod adjustment.
  - The tappet covers on Milwaukee-Eight engines are quite tall, and care should be taken not to allow the lock-nut to drop to the bottom of the adjuster when installing Quicke pushrods. It is suggested that the 1/4" wrench be applied to the adjuster screw with the nut above it until the adjuster is screwed out of the pushrod, and the nut can be threaded onto the adjuster screw.
22. Adjust pushrods according to the instructions provided with the pushrod kit. Close the pushrod covers and install the supplied S&S pushrod cover keepers.
  23. Repeat steps 19 through 22 for the other cylinder.
  24. Reattach battery ground cable, and reinstall spark plugs.