

Instruction 510-0347
5-27-15 Rev. 4
Copyright © 2015
by S&S® Cycle, Inc.

S&S® Cycle, Inc.

14025 Cty Hwy G PO Box 215
Viola, Wisconsin 54664
Phone: 608-627-1497 • Fax: 608-627-1488
Technical Service Phone: 608-627-TECH (8324)
Technical Service Email: sstech@sscycle.com
Website: www.sscycle.com



All rights reserved.
Printed in the U.S.A.

Installation Instructions: S&S TC3 Oil Pumps for 1999-up Harley-Davidson® Big Twin Engines

DISCLAIMER:

These parts are designed as service repair components for the maintenance of Harley-Davidson® motorcycle engines. They are intended to provide the same fit and function as the stock components that they replace.

It is the sole and exclusive responsibility of the user to determine the suitability of the product for his or her use, and the user shall assume all legal, personal injury risk and liability and all other obligations, duties, and risks associated therewith.

The words Harley®, Harley-Davidson®, H-D®, Sportster®, Evolution®, and all H-D part numbers and model designations are used in reference only. S&S Cycle is not associated with Harley-Davidson, Inc.

SAFE INSTALLATION AND OPERATION RULES:

Before installing your new S&S part it is your responsibility to read and follow the installation and maintenance procedures in these instructions and follow the basic rules below for your personal safety.

- Gasoline is extremely flammable and explosive under certain conditions and toxic when breathed. Do not smoke. Perform installation in a well ventilated area away from open flames or sparks.
- If motorcycle has been running, wait until engine and exhaust pipes have cooled down to avoid getting burned before performing any installation steps.
- Before performing any installation steps disconnect battery to eliminate potential sparks and inadvertent engagement of starter while working on electrical components.
- Read instructions thoroughly and carefully so all procedures are completely understood before performing any installation steps. Contact S&S with any questions you may have if any steps are unclear or any abnormalities occur during installation or operation of motorcycle with a S&S part on it.
- Consult an appropriate service manual for your motorcycle for correct disassembly and reassembly procedures for any parts that need to be removed to facilitate installation.
- Use good judgment when performing installation and operating motorcycle. Good judgment begins with a clear head. Don't let alcohol, drugs, or fatigue impair your judgment. Start installation when you are fresh.
- Be sure all federal, state, and local laws are obeyed with the installation.
- For optimum performance and safety and to minimize potential damage to carb or other components, use all mounting hardware that is provided and follow all installation instructions.
- Motorcycle exhaust fumes are toxic and poisonous and must not be breathed. Run motorcycle in a well ventilated area where fumes can dissipate.

IMPORTANT NOTICE:

Statements in this instruction sheet preceded by the following words are of special significance.



WARNING

Means there is the possibility of injury to yourself or others.



CAUTION

Means there is the possibility of damage to the part or motorcycle.

NOTE

Other information of particular importance has been placed in italic type.

S&S recommends you take special notice of these items.

WARRANTY:

All S&S parts are guaranteed to the original purchaser to be free of manufacturing defects in materials and workmanship for a period of twelve (12) months from the date of purchase. Merchandise that fails to conform to these conditions will be repaired or replaced at S&S' option if the parts are returned to us by the purchaser within the 12 month warranty period or within 10 days thereafter.

In the event warranty service is required, the original purchaser must call or write S&S immediately with the problem. Some problems can be rectified by a telephone call and need no further course of action.

A part that is suspect of being defective must not be replaced by a Dealer without prior authorization from S&S. If it is deemed necessary for S&S to make an evaluation to determine whether the part was defective, a return authorization number must be obtained from S&S. The parts must be packaged properly so as to not cause further damage and be returned prepaid to S&S with a copy of the original invoice of purchase and a detailed letter outlining the nature of the problem, how the part was used and the circumstances at the time of failure. If after an evaluation has been made by S&S and the part was found to be defective, repair, replacement, or refund will be granted.

ADDITIONAL WARRANTY PROVISIONS:

- (1) S&S shall have no obligation in the event an S&S part is modified by any other person or organization.
- (2) S&S shall have no obligation if an S&S part becomes defective in whole or in part as a result of improper installation, improper maintenance, improper use, abnormal operation, or any other misuse or mistreatment of the S&S part.
- (3) S&S shall not be liable for any consequential or incidental damages resulting from the failure of an S&S part, the breach of any warranties, the failure to deliver, delay in delivery, delivery in non-conforming condition, or for any other breach of contract or duty between S&S and a customer.
- (4) S&S parts are designed exclusively for use in Harley-Davidson® and other American v-twin motorcycles. S&S shall have no warranty or liability obligation if an S&S part is used in any other application.

INSTALLATION INSTRUCTIONS FOR THE FOLLOWING S&S PART NUMBERS

310-0640, TC3 Oil Pump Kit 1999-2006 except 06 Dyna®.

310-0641 TC3 Oil Pump Kit 2007–Up BT and 2006 Dyna®.

NOTES:

- Installation of S&S oil pump requires the use of special tools and repair manuals for the model bike you will be doing the work on. Attempting the installation without the proper tools and manuals will be difficult. Damage can result which will not be covered under warranty.
- Possible failure may result if thread locking compound is not applied to the cam drive sprocket flange bolts. Always prepare threads according to the instructions on the container.
- 2000-'02 Harley-Davidson® Softail® models are equipped with a pinion shaft bearing retainer that is unique to these models. See Picture 1 When installing an S&S oil pump in these models, installer must ensure that the left retaining screw head does not contact the pump body. It is suggested that the pump and cam plate be "dry fitted" without the gerotors or o-rings before final assembly to make sure there is no gap between the cam plate and the mounting surface of the crankcase. If a .001" feeler gauge can not be inserted between the cam support plate and the crankcase, the installation may proceed per these instructions. See Picture 2 If there is contact between the oil pump and the retaining screw, please call S&S technical support at (608) 627-1497.

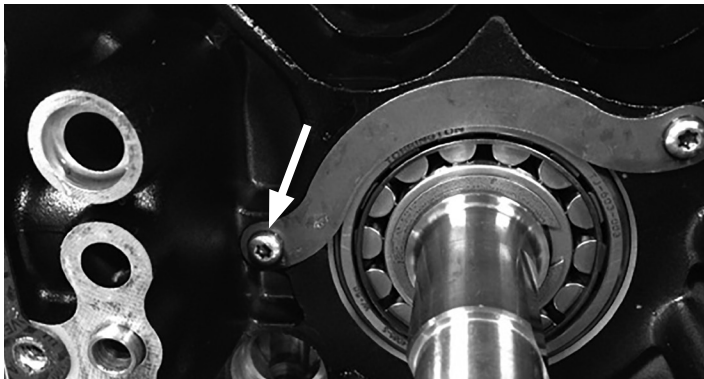

Picture 1

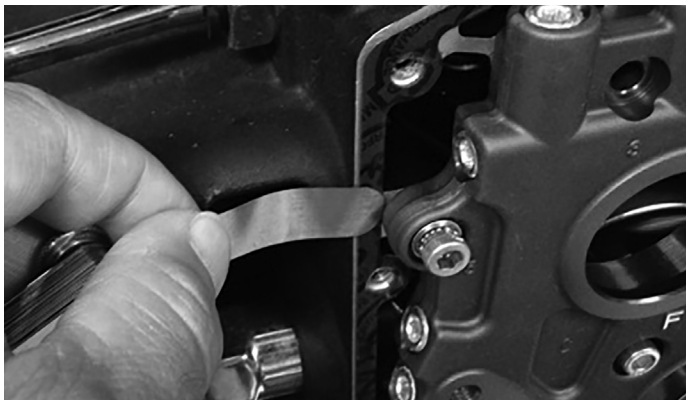

Picture 2

- All reference to Harley-Davidson® part numbers is for identification purposes only. We in no way are implying that any of S&S Cycle's products are original equipment parts or that they are equivalent to the corresponding Harley-Davidson® part numbers

Follow Steps 1-8 For All Installations To Prepare For installation

1. Refer to proper H-D® manual for the model of bike you will be working on for the removal of existing oil pump.
2. Once you have successfully removed the cam plate and oil pump from the motor inspect flywheel for pinion shaft run out. Refer to manual for proper inspection procedure.
3. If you will be reusing your existing cam plate. Wash cam plate and inspect bearing bores / bushing bores for size, refer to the manufacturers specifications for service wear limits on these bores, replace bearings as necessary. It is easier to replace the bearings now while the engine is apart. Inspect the pump mating surface for scoring; if the surface where the pump gears run against the plate has been scored this could adversely affect oil pressure.
NOTE: If your cam plate has non serviceable oil galley plugs and has been exposed to debris from previous engine malfunctions or other foreign material, it is almost impossible to effectively clean the passages. A new cam plate may be a better option.
4. It is also a good idea to clean and inspect the pressure relief valve of the cam support plate if you will be reusing your existing one. Refer to the manual for proper removal of the pressure relief valve. The pressure relief valve should move freely in the bore.
5. Inspect or replace chain tensioners as needed refer to H-D® manual for service wear limits.
6. Inspect inner cam bearings, now is the time to replace these bearings while the engine is apart. Refer to manual for proper procedure and proper tools to use when replacing these bearings. **NOTE:** Full compliment bearings are recommended.
7. Clean and flush your oil tank and oil lines. Any foreign matter that has accumulated in your oil tank will be sucked through your new oil pump. Oil pans with riveted-in baffle can be very hard to clean, it is very important to remove all debris from the pan. Also, when installing the S&S oil pump, the oil filter should be changed.
8. Remove pump from package and inspect pump for shipping damage. If there is any damage contact S&S immediately. Make sure pump has all parts shown in assembly drawing. **Last page**

S&S Oil pump installation

- Make sure you have the proper pump for the style of cam plate you will be using. Late style and early style pumps have different bolt patterns. One screw located in the upper right corner when looking at the front of the pump is located differently. An early pump can't be used on a late cam plate and a late pump will not fit on an early cam plate. **See Figure 1 below.**

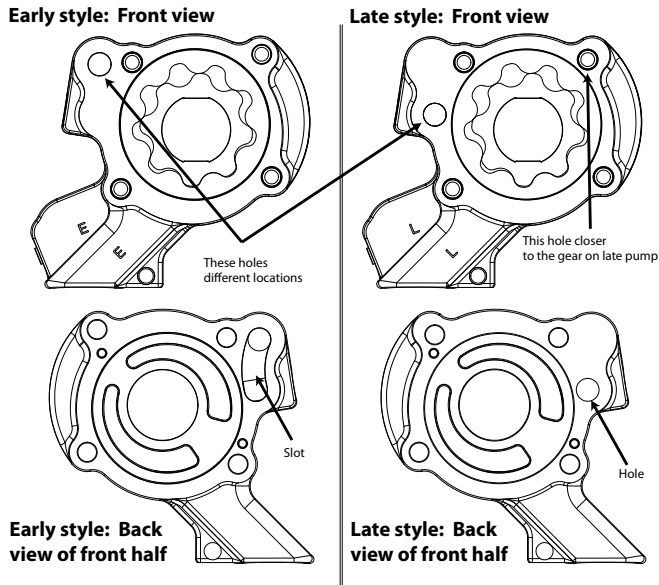

Figure 1

NOTE: If using an S&S 1999-'06 style cam plate a 2007-later style oil pump must be used

- Disassemble and wash all parts. Check to make sure all plugs have been installed.
- We feel it is easiest to assemble pump into motor one piece at a time.
- First install scavenge port O-ring in case (do not install O-ring onto pump). Put some engine oil or assembly lube on the O-ring to make installing the pump housing easier.
- Install rear pump housing. Push the housing into the O-ring with your thumb. Make sure it goes in all the way.

NOTE: The drive flats on these gears are purposely wider than the stock drive flats. This allows for more freedom of movement. This helps prevent excessive side loading but still gives plenty of engagement for turning the rotors.

- Apply assembly lube to inner return gear set, and assemble inner gear inside outer gear. Align the inner gear with the flat on the pinon shaft and install gear set into inner pump body as an assembly. Make sure the relief cut side of the inner gear goes toward the engine **See Picture 3.**

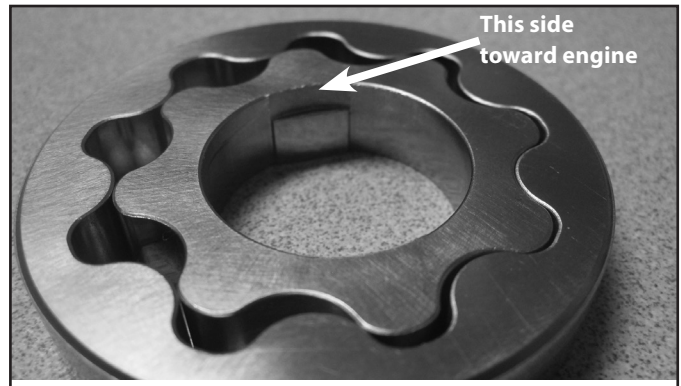

Picture 3

NOTE: Do not mix and match inner and outer gears keep them as sets as they are shipped in the pump.

- Install two $\frac{1}{8}$ " x $\frac{3}{4}$ " dowels into pump housing. See #7 in line drawing on Page 4.
- Install divider plate
- Apply assembly lube to second return gear set. Place gear set into outer pump body and install outer pump body onto inner pump body.
- Place straight edge across front of cam chest and make sure the face of the pump does not protrude past the cam chest gasket surface. **Figure 2**

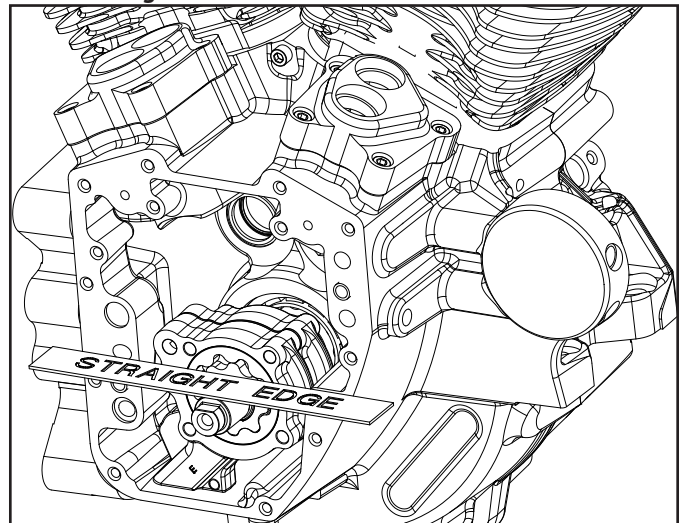

Figure 2

- If pump protrudes past gasket surface check to see that the pump is installed all the way into the scavenge port O-ring. If this doesn't solve the issue and you cannot see any other areas of interference contact the S&S tech line at 608-627-8324.
- Apply assembly lube to the .250 wide feed gear set and install into pump. Be sure this does not protrude past the front face of the pump body.

NOTES

- If using a stock cam support plate with the S&S oil pump we **DO NOT** recommend stretching the pressure relief spring to increase oil pressure as the pump will normally supply plenty of oil pressure. Stretching the spring may result in overly high oil pressure which could result in leaks around hoses and or gaskets. Excessive oil pressure causes higher oil temperatures and uses more power to turn the pump.
- If installing oil pump with the motor in the bike put transmission in high gear and raise rear wheel off the table so you can turn the engine over using rear wheel.
- S&S recommends replacing stock spring style hose clamps on oil cooler lines, where they attach to the filter adaptor, with crimp style clamps. Spring clamps do not provide adequate clamping force to keep oil lines secure on the hose nipples under extended high rpm operation.

21. Install cam support plate following the H-D® service manual or manufacturer's specific instructions. Apply a small amount of loctite 243 to screws that hold the cam plate to crankcase. Tighten them to 100 in-lb, following the torque sequence shown in **Figure 3** for the cam plate screws (in circles). Apply a small amount of Loctite 243 to the 4 supplied ¼" 20 x 2" bolts, install them with the 4 supplied ¼" washers to secure oil pump to cam plate.



Use loctite sparingly on pump screws. Be careful not to get excess loctite between the pump half's or in the pump gear bores as damage could occur

22. Refer to **Figure 3** for proper torque sequence. While rotating the engine, alternately tighten bolts 1 and 2 (shown in squares) until the bolts are snug. Tighten bolts 3 and 4 until they are snug. Finally, torque the four bolts in the sequence shown in to 100 in-lbs. This procedure ensures that the oil pump is properly centered
23. Reinstall all remaining components according to the proper HD® service manual.



Failure of fasteners or parts caused by incorrect installation can cause extensive damage not covered under warranty

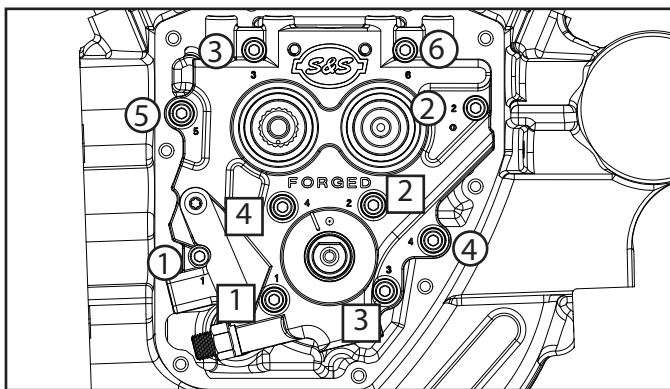
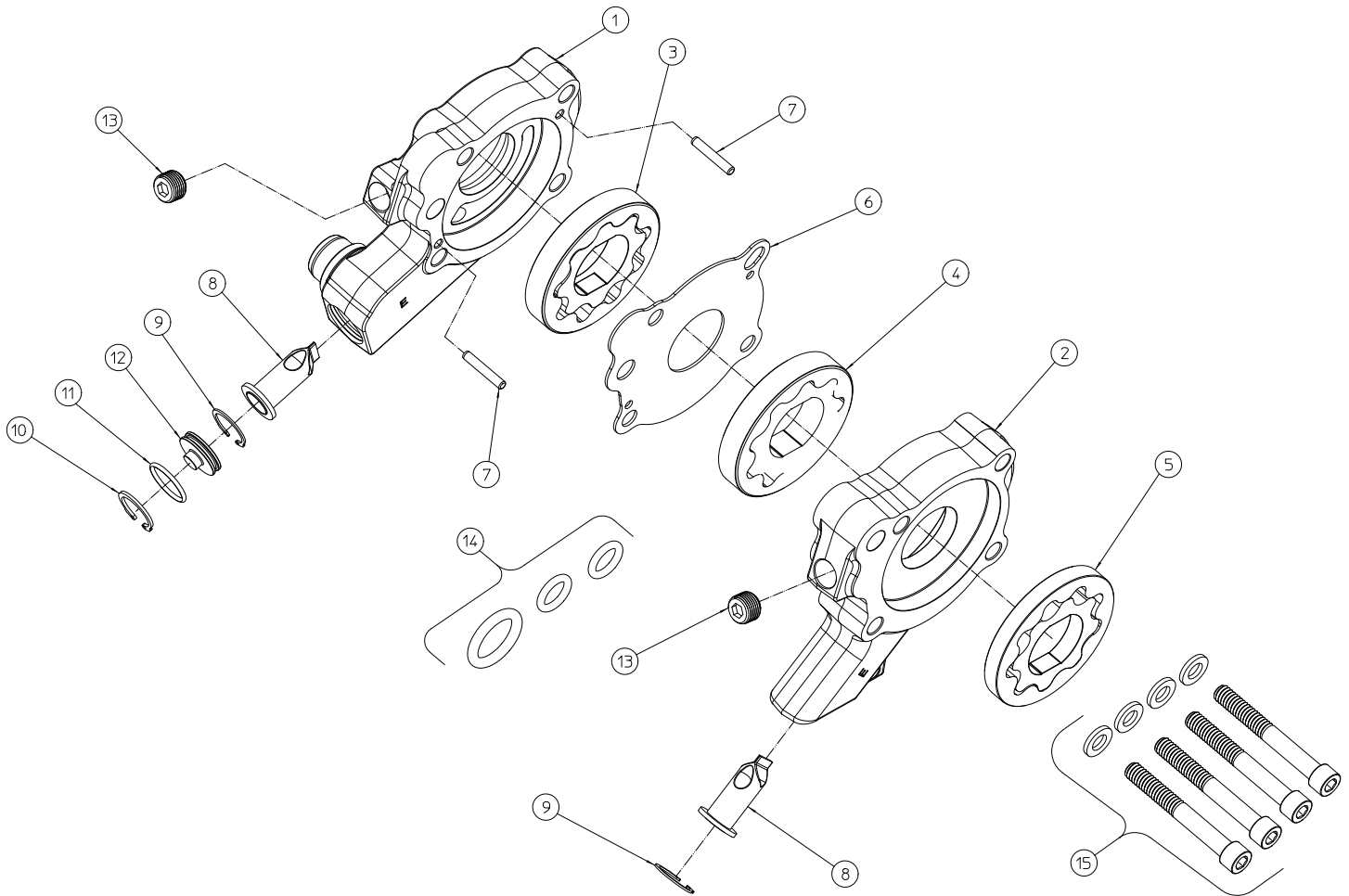

Figure 3



Oil Pump Replacement Parts			
Item #	Part number	Description	Quantity
1	NA	Oil pump body case return section	1
2	NA	Oil pump body cam chest return / pressure feed	1
3	310-0644	Oil pump rotor set, flywheel cavity return	1
4	36-7021-S	Oil pump rotor set, cam chest cavity return	1
5	310-0561	Oil pump rotor set, supply	1
6	310-0516	Plate, divider	1
7	106-3794	Dowel Pin, .125 x .750 Hardened Steel	2
8	310-0546	Debris screen	2
9	500-0320	Internal Retaining Ring, .625	2
10	500-0209	Internal Retaining Ring, 17mm	1
11	500-0321	O-ring, 1.5mm x 14mm, Viton	1
12	310-0564	Oil pump return plug	1
13	50-8331	Plug, Pipe 1/8" 27	2
14	500-0326	O-ring kit	1
15	500-0327	Screw, Kit, Oil Pump, 1999-Up BT (1/4" 20 x 2" SHCS w/washers)	1
16	51-9002	Assembly lube (Not pictured)	1
17	51-9003	Loctite #243 Blue (Not pictured)	1
18	51-9004	Loctite #262 Red (Not pictured)	1

Instruction 510-0354
05-18-15 Rev 2
Copyright © 2015
by S&S® Cycle, Inc.

S&S® Cycle, Inc.

14025 Cty Hwy G PO Box 215
Viola, Wisconsin 54664

Phone: 608-627-1497 • Fax: 608-627-1488
Technical Service Phone: 608-627-TECH (8324)
Technical Service Email: sstech@sscycle.com
Website: www.sscycle.com



All rights reserved.
Printed in the U.S.A.

Installation Instructions: TC3 Cam Support Plates for 1999-up Harley-Davidson® Big Twins.

DISCLAIMER:

These parts are designed as service repair components for the maintenance of Harley-Davidson® motorcycle engines. They are intended to provide the same fit and function as the stock components that they replace.

It is the sole and exclusive responsibility of the user to determine the suitability of the product for his or her use, and the user shall assume all legal, personal injury risk and liability and all other obligations, duties, and risks associated therewith.

The words Harley®, Harley-Davidson®, H-D®, Sportster®, Evolution®, and all H-D part numbers and model designations are used in reference only. S&S Cycle is not associated with Harley-Davidson, Inc.

SAFE INSTALLATION AND OPERATION RULES:

Before installing your new S&S part it is your responsibility to read and follow the installation and maintenance procedures in these instructions and follow the basic rules below for your personal safety.

- Gasoline is extremely flammable and explosive under certain conditions and toxic when breathed. Do not smoke. Perform installation in a well ventilated area away from open flames or sparks.
- If motorcycle has been running, wait until engine and exhaust pipes have cooled down to avoid getting burned before performing any installation steps.
- Before performing any installation steps disconnect battery to eliminate potential sparks and inadvertent engagement of starter while working on electrical components.
- Read instructions thoroughly and carefully so all procedures are completely understood before performing any installation steps. Contact S&S with any questions you may have if any steps are unclear or any abnormalities occur during installation or operation of motorcycle with a S&S part on it.
- Consult an appropriate service manual for your motorcycle for correct disassembly and reassembly procedures for any parts that need to be removed to facilitate installation.
- Use good judgment when performing installation and operating motorcycle. Good judgment begins with a clear head. Don't let alcohol, drugs, or fatigue impair your judgment. Start installation when you are fresh.
- Be sure all federal, state, and local laws are obeyed with the installation.
- For optimum performance and safety and to minimize potential damage to carb or other components, use all mounting hardware that is provided and follow all installation instructions.
- Motorcycle exhaust fumes are toxic and poisonous and must not be breathed. Run motorcycle in a well ventilated area where fumes can dissipate.

IMPORTANT NOTICE:

Statements in this instruction sheet preceded by the following words are of special significance.



WARNING

Means there is the possibility of injury to yourself or others.



CAUTION

Means there is the possibility of damage to the part or motorcycle.

NOTE

Other information of particular importance has been placed in italic type.

S&S recommends you take special notice of these items.

WARRANTY:

All S&S parts are guaranteed to the original purchaser to be free of manufacturing defects in materials and workmanship for a period of twelve (12) months from the date of purchase. Merchandise that fails to conform to these conditions will be repaired or replaced at S&S' option if the parts are returned to us by the purchaser within the 12 month warranty period or within 10 days thereafter.

In the event warranty service is required, the original purchaser must call or write S&S immediately with the problem. Some problems can be rectified by a telephone call and need no further course of action.

A part that is suspect of being defective must not be replaced by a Dealer without prior authorization from S&S. If it is deemed necessary for S&S to make an evaluation to determine whether the part was defective, a return authorization number must be obtained from S&S. The parts must be packaged properly so as to not cause further damage and be returned prepaid to S&S with a copy of the original invoice of purchase and a detailed letter outlining the nature of the problem, how the part was used and the circumstances at the time of failure. If after an evaluation has been made by S&S and the part was found to be defective, repair, replacement, or refund will be granted.

ADDITIONAL WARRANTY PROVISIONS:

- (1) S&S shall have no obligation in the event an S&S part is modified by any other person or organization.
- (2) S&S shall have no obligation if an S&S part becomes defective in whole or in part as a result of improper installation, improper maintenance, improper use, abnormal operation, or any other misuse or mistreatment of the S&S part.
- (3) S&S shall not be liable for any consequential or incidental damages resulting from the failure of an S&S part, the breach of any warranties, the failure to deliver, delay in delivery, delivery in non-conforming condition, or for any other breach of contract or duty between S&S and a customer.
- (4) S&S parts are designed exclusively for use in Harley-Davidson® and other American v-twin motorcycles. S&S shall have no warranty or liability obligation if an S&S part is used in any other application.

NOTES AND PREPARATION INSTRUCTIONS – ALL INSTALLATIONS

310-0623 TC3 Cam Support Plate for 1999-'06 models except 2006 Dyna® models (must use late style pump, late style hydraulic chain tensioners).

310-0625 TC3 Cam Support Plate for 2007-up and 06 Dyna® models with bushing style cams.

NOTES:

- S&S does not manufacture a Cam Support Plate for use with early 1999-2006 oil pumps or spring loaded chain tensioners as we feel these are inferior to the later style components and are best not used.
- Possible failure may result if thread locking compound is not applied to the cam drive sprocket flange bolts. Always prepare threads according to the instructions on the container.
- All reference to Harley-Davidson® part numbers is for identification purposes only. We in no way are implying that any of S&S Cycle's products are original equipment parts or that they are equivalent to the corresponding Harley-Davidson® part numbers
- Installation of S&S cam support plate requires the use of special tools and repair manuals for the model bike you will be doing the work on. Attempting the installation without the proper tools and manuals will be difficult. Damage can result which will not be covered under warranty. **See Pictures 1 and 2**

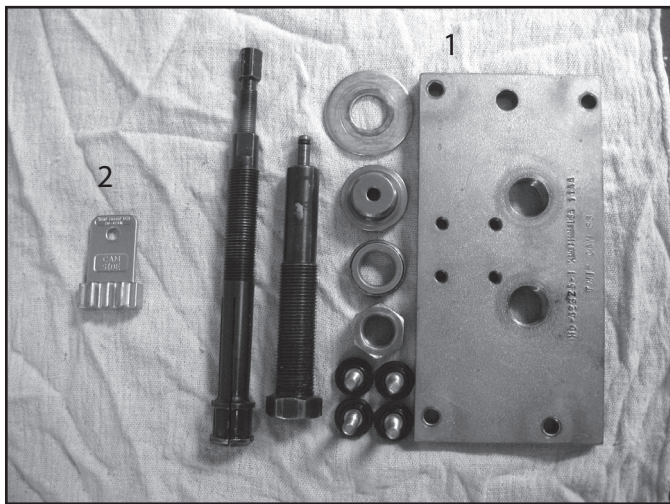

Picture 1 Special tools required for 2007-later models

1. Camshaft Needle Bearing Remover / Installer, HD® Part Number: 42325
2. Crankshaft / Camshaft Sprocket Locking Tool, HD® Part Number: 47941 (for late roller style chains).

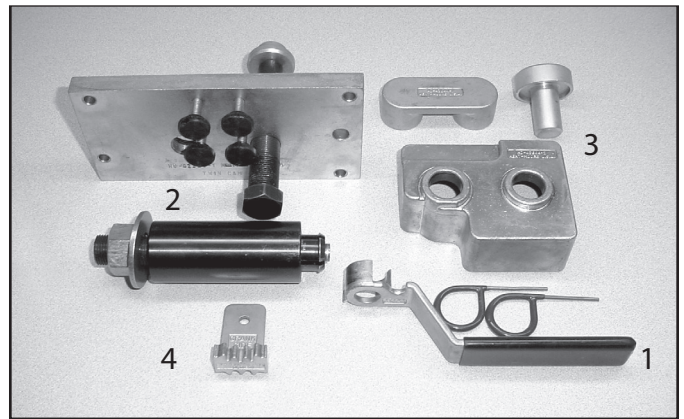

Picture 2 Special tools required for 1999-'06 models

1. H-D #42313 Cam Chain Tensioner Unloader for removing cam chains from 1999-2006 bikes with spring loaded cam chain tensioners.
 2. H-D #42325 Camshaft Needle Bearing Remover/Installer
 3. H-D #43644 Camshaft Remover/Installer
 4. H-D #42314 Crankshaft/Camshaft Sprocket Locking Tool
- Some early 1999 model engines do not have a chain oiler boss. See Pictures 3 and 4. If Your engine does not have this boss, screw #500-0346 must be installed to block the oil hole in the back side of the cam plate. Install with red thread locker and tighten to 70 in-lb. **See Figure 1.**

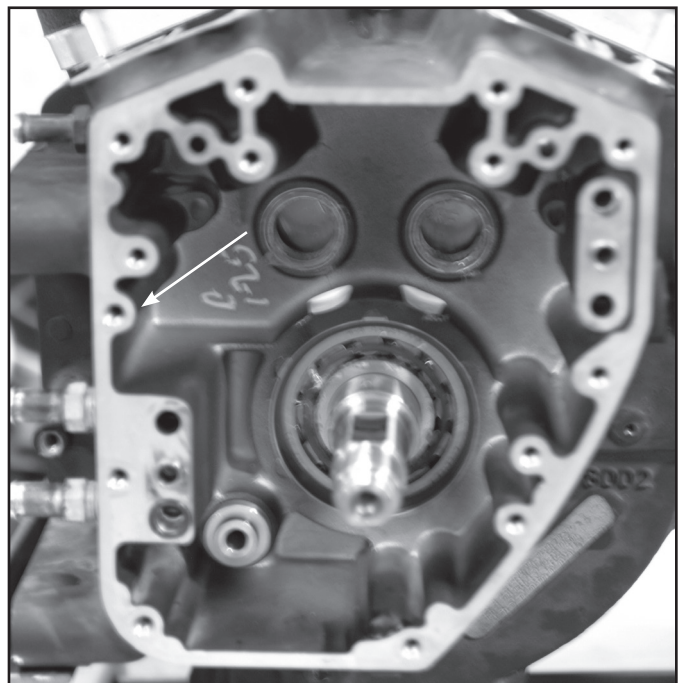

Picture 3

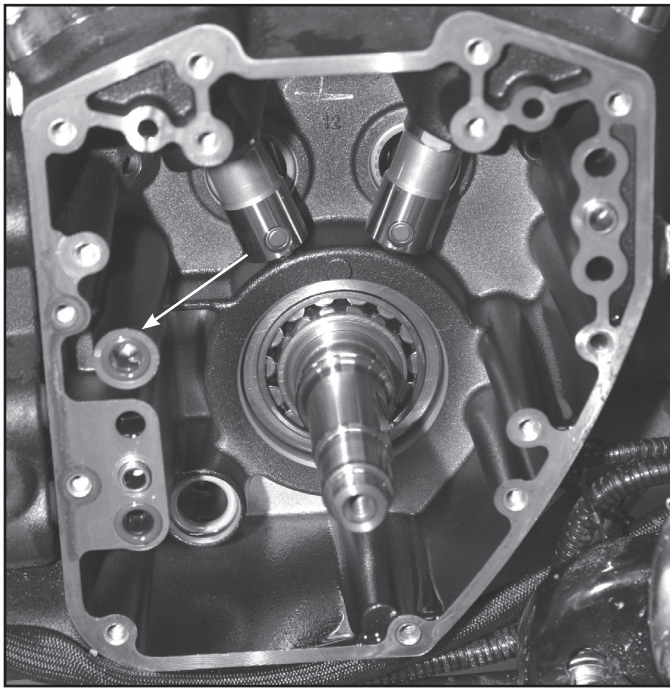

Picture 4

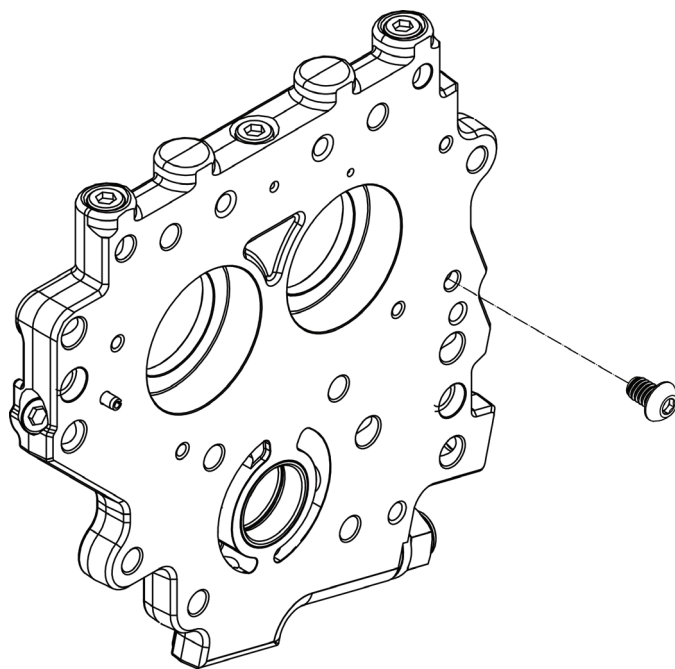

Figure 1

• 1999 models used interchangeable ball bearings on the outer end of both cams. For 2000 and up, the rear bearing is a roller type and the front bearing is a ball bearing type. It is highly recommended to update 1999 models to the 2000 and up bearing set, pictured in **Picture 5**. These bearings are included in the S&S cam installation kits for chain drive cams.



Picture 5

Installation steps for all cam plates

1. Inspect plate to verify that it is the correct part number for your application. Refer to assembly drawings on last two pages. Find drawing for the plate that you have. Check to make sure all parts listed have been included. Call S&S if any parts are missing.
2. Check to make sure all plugs have been installed.
3. Wash cam plate with clean parts cleaning solvent.
4. Before starting any work on motorcycle disconnect negative terminal of battery to eliminate potential sparks and inadvertent engagement of starter while working on motorcycle.
5. Clean and flush your oil tank/pan and oil lines to prevent foreign material from being sucked through your oil pump and through your new cam support plate. The oil filter should also be changed.

NOTE: It is very difficult to remove all of the debris from oil pans with the swaged on baffle plate without removing the plate. If you have a pan with a swaged on baffle plate and have had a large amount of debris go through the motor it is advisable to remove this plate clean the pan and then drill and tap the pan to accept screws to reinstall the plate.

6. Refer to proper H-D manual for the model of bike you will be working on for the proper removal of all components. Save the original fasteners to be reused when S&S cam support plate is installed.
7. Once you have properly removed the cam support plate and oil pump from the motor per HD® manual, inspect flywheel for pinion shaft run out. Refer to manual for proper inspection procedure. S&S recommends no more than .003" total indicated run out on pinion shaft while checked in the cases.
8. If you intend to reuse your existing oil pump it must be inspected to ensure that it is serviceable. Refer to manufacturer service wear limits for the gears and pump body bores. If the areas under the pump gears are scored (kidney shaped ports, separator plate) this will adversely affect the pumps ability to supply and or return oil properly to and from your motor.
9. Inspect inner cam bearings, now is the time to replace these bearings while the engine is apart. Refer to manual for proper procedure and proper tools to use when replacing these bearings.
10. Install cam plate, oil pump, and cams per the factory manual or

instructions provided by manufacturer of aftermarket cams or oil pump. S&S recommends that all mounting hardware on cam support plate and oil pump be tightened to 100 in-lb using the torque sequences shown in **Figure 2**. Cam support plate fasteners are shown in circles. Oil pump fasteners are shown in squares.

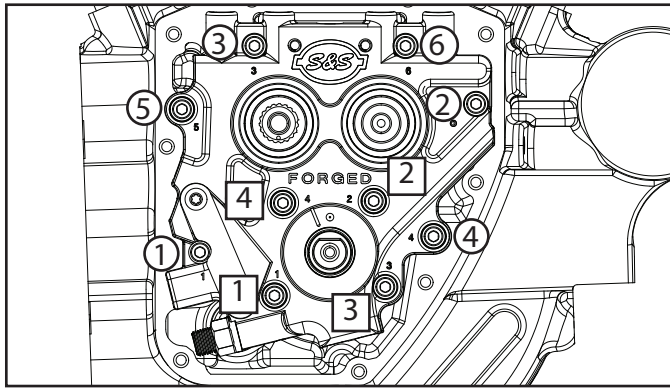

Figure 2

11. Pressure relief valve on S&S cam plate has been set at the factory to relieve at approximately 40 psi. Using a caliper note the distance from the end of the pressure relief screw to the pressure relief nut and note this dimension for future reference. **See Figure 3.**
12. The pressure relief valve is designed to keep the pump from building excessive oil pressure at high RPM's. Resist the temptation to turn the screw in to try and raise the low rpm oil pressure. If your engine has no oil pressure at idle, turning the pressure relief screw in more will normally not help this condition, as this pressure will be below the operating point of the pressure relief valve. If you do adjust the pressure relief valve to something other than the factory setting. We recommend not turning it more than ½ turn at a time. One half turn of the screw will move the adjuster .025" which typically changes oil pressure approximately 4 psi, but other factors may effect the actual change in pressure.

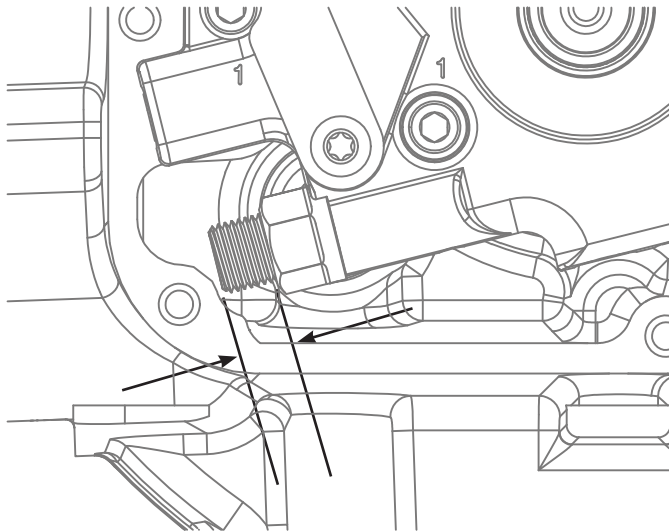
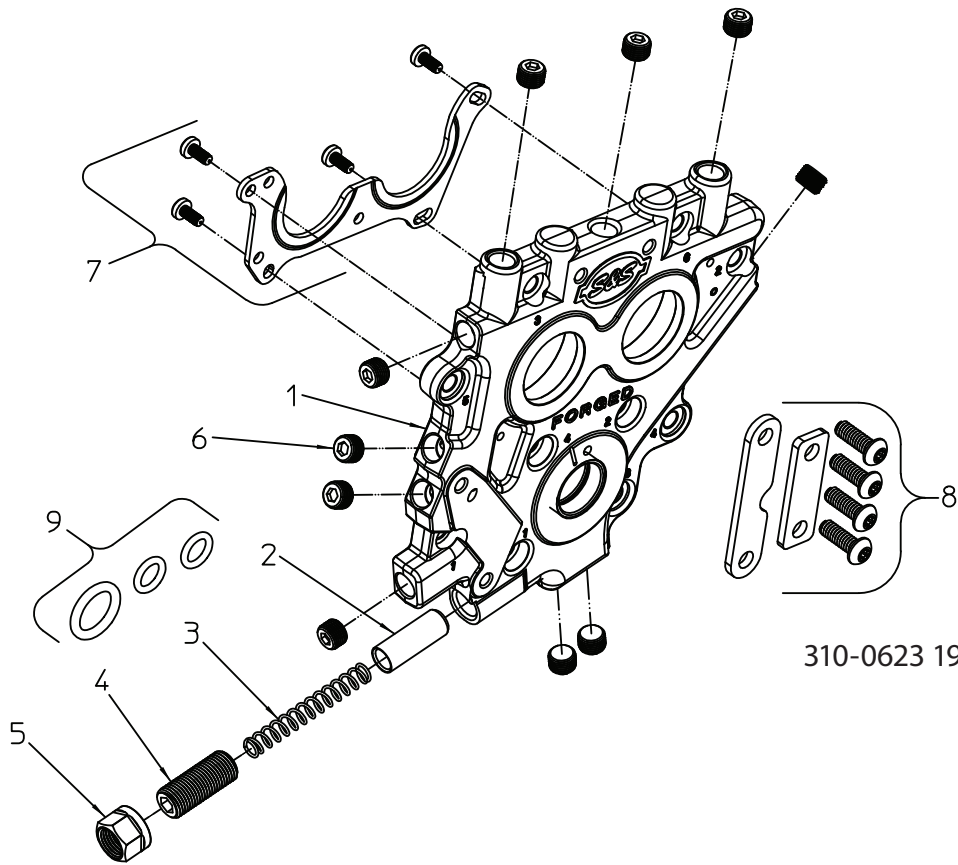

Figure 3

NOTES:

- Turning the pressure adjusting screw in more than necessary will cause high oil pressure at high RPM's but will also needlessly raise oil temperature and rob horsepower without really raising low rpm oil pressure. Ideally you want to keep your oil pressure as low as you can while keeping the tappets quiet.
- If installing cam plate with the motor in the bike put transmission in high gear and raise rear wheel off the table so you can turn the engine over using rear wheel
- S&S does not supply hydraulic cam chain tensioners with new cam plates. You will either need to reuse your stock tensioners or purchase new ones. They are available from S&S Cycle's Viola V-twin® service parts catalog. Part numbers 330-0283 and 330-0384 for primary and secondary tensioners.
- Hydraulic tensioner block off kit is included for use with gear drive cams. Follow gear drive cam instructions for installation.
- S&S recommends replacing stock spring style hose clamps on oil cooler lines, where they attach to the filter adaptor, with crimp style clamps. Spring clamps do not provide adequate clamping force to keep oil lines secure on the hose nipples under extended high rpm operation.



310-0623 1999-'06

Cam Plate Replacement Parts		
Item #	Part number	Description
1	NA	Cam support plate
2	31-6082-S	Pressure relief valve
3	31-6018	Pressure relief spring
4	170-0252	Pressure relief adjusting screw
5	170-0251	Pressure relief adjusting screw lock nut
6	50-8331	1/8" 27 taper pipe plug
7	330-0015	Bearing retention plate kit
8	106-5723	Hydraulic tensioner block off kit
9	500-0326	O-ring kit
10	51-9002	Assembly lube (Not pictured)
11	51-9003	Loctite #243 Blue .5ml (Not pictured)
12	51-9004	Loctite #262 Red .5ml (Not pictured)

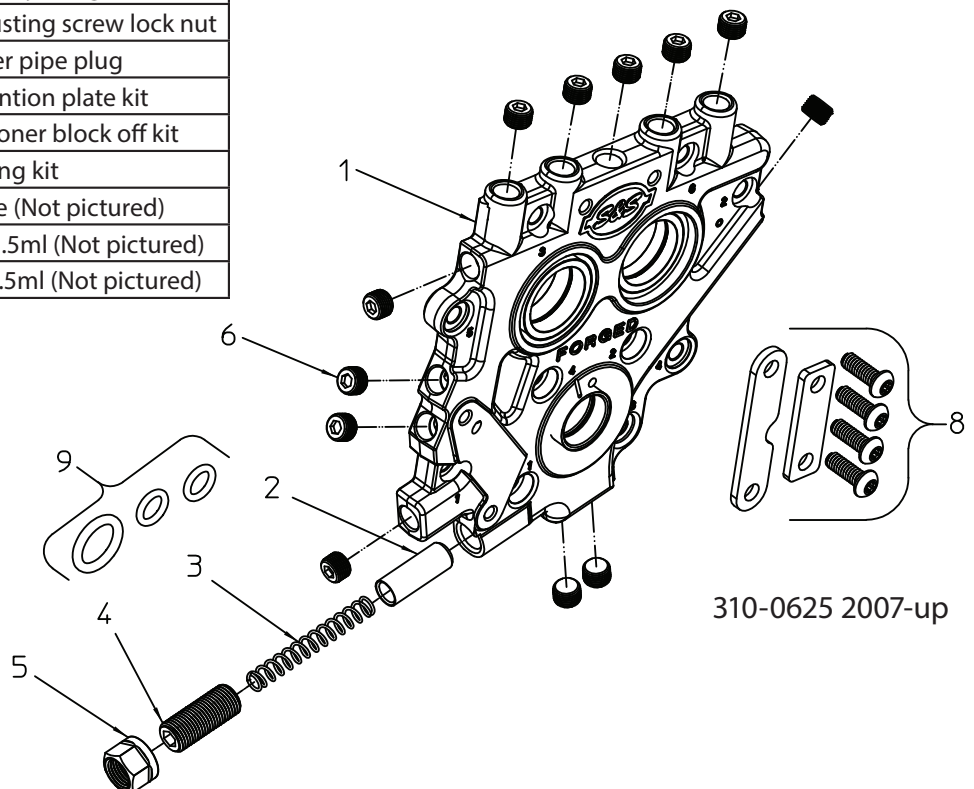

310-0625 2007-up

Instruction 106-6046

09-20-16

Version 3

Copyright © 2012, 2015, 2016

by S&S® Cycle, Inc.

All rights reserved.

Printed in the U.S.A.

S&S® Cycle, Inc.

**14025 Cty Hwy G
Viola, Wisconsin 54664**

Phone: 608-627-1497 • Fax: 608-627-1488

Technical Service Phone: 608-627-TECH (8324)

Technical Service Email: sstech@sscycycle.com

Website: www.sscycycle.com



Installation and Adjustment Instructions for S&S Adjustable Pushrods For Hydraulic Tappets

DISCLAIMER:

Many S&S parts are designed for high performance, closed course, racing applications and are intended for the very experienced rider only. The installation of S&S parts may void or adversely affect your factory warranty. In addition such installation and use may violate certain federal, state, and local laws, rules and ordinances as well as other laws when used on motor vehicles used on public highways. Always check federal, state, and local laws before modifying your motorcycle. It is the sole and exclusive responsibility of the user to determine the suitability of the product for his or her use, and the user shall assume all legal, personal injury risk and liability and all other obligations, duties, and risks associated therewith.

NOT LEGAL FOR SALE OR USE IN CALIFORNIA ON ANY POLLUTION CONTROLLED MOTOR VEHICLES

SAFE INSTALLATION AND OPERATION RULES:

Before installing your new S&S part, it is your responsibility to read and follow the installation and maintenance procedures in these instructions and follow the basic rules below for your personal safety.

- Gasoline is extremely flammable and explosive under certain conditions and toxic when breathed. Do not smoke. Perform installation in a well ventilated area away from open flames or sparks.
- If motorcycle has been running, wait until engine and exhaust pipes have cooled down to avoid getting burned before performing any installation steps.
- Before performing any installation steps, disconnect battery to eliminate potential sparks and inadvertent engagement of starter while working on electrical components.
- Read instructions thoroughly and carefully so all procedures are completely understood before performing any installation steps. Contact S&S with any questions you may have if any steps are unclear or any abnormalities occur during installation or operation of motorcycle with an S&S part on it.
- Consult an appropriate service manual for your motorcycle for correct disassembly and reassembly procedures for any parts that need to be removed to facilitate installation.
- Use good judgment when performing installation and operating motorcycle. Good judgment begins with a clear head. Don't let alcohol, drugs or fatigue impair your judgment. Start installation when you are fresh.
- Be sure all federal, state and local laws are obeyed with the installation.
- For optimum performance and safety and to minimize potential damage to components, use all mounting hardware that is provided and follow all installation instructions.
- Motorcycle exhaust fumes are toxic and poisonous and must not be breathed. Run motorcycle in a well ventilated area where fumes can dissipate.

IMPORTANT NOTICE:

Statements in this instruction sheet preceded by the following words are of special significance.



WARNING

Means there is the possibility of injury to yourself or others.



CAUTION

Means there is the possibility of damage to the part or motorcycle.

NOTE

Other information of particular importance has been placed in italic type.

S&S recommends you take special notice of these items.

WARRANTY:

All S&S parts are guaranteed to the original purchaser to be free of manufacturing defects in materials and workmanship for a period of twelve (12) months from the date of purchase. Merchandise that fails to conform to these conditions will be repaired or replaced at S&S's option if the parts are returned to us by the purchaser within the 12 month warranty period or within 10 days thereafter.

In the event warranty service is required, the original purchaser must call or write S&S immediately with the problem. Some problems can be rectified by a telephone call and need no further course of action.

A part that is suspect of being defective must not be replaced by a Dealer without prior authorization from S&S. If it is deemed necessary for S&S to make an evaluation to determine whether the part was defective, a return authorization number must be obtained from S&S. The parts must be packaged properly so as to not cause further damage and be returned prepaid to S&S with a copy of the original invoice of purchase and a detailed letter outlining the nature of the problem, how the part was used and the circumstances at the time of failure. If after an evaluation has been made by S&S and the part was found to be defective, repair, replacement or refund will be granted.

ADDITIONAL WARRANTY PROVISIONS:

- (1) S&S shall have no obligation in the event an S&S part is modified by any other person or organization.
- (2) S&S shall have no obligation if an S&S part becomes defective in whole or in part as a result of improper installation, improper maintenance, improper use, abnormal operation, or any other misuse or mistreatment of the S&S part.
- (3) S&S shall not be liable for any consequential or incidental damages resulting from the failure of an S&S part, the breach of any warranties, the failure to deliver, delay in delivery, delivery in non-conforming condition, or for any other breach of contract or duty between S&S and a customer.

Introduction

S&S adjustable pushrods, for engines with late style hydraulic tappets, may be one of two types. See **Picture 1**. S&S Standard Adjustable Pushrods, which feature a threaded adjusting sleeve and a fixed adjusting screw, generally require the removal of the rocker covers and arms for installation or removal. S&S Quickee Pushrods have an adjusting screw that threads into the pushrod body, allowing the pushrod to collapse, becoming short enough to be installed and removed from an engine without disassembling the rocker covers. Quickee pushrods are also used in the S&S Valve Train Upgrade Kits for 1966-84 big twins.

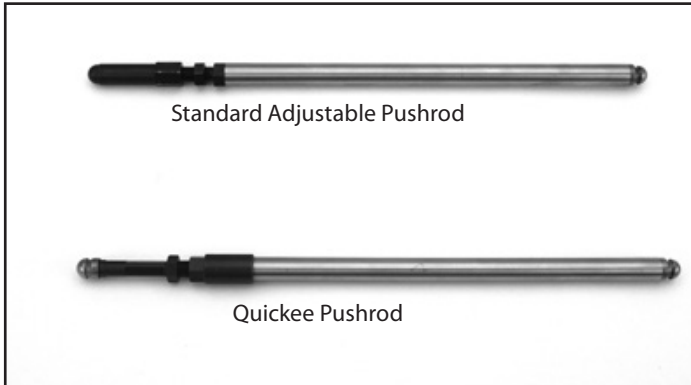

Picture 1

NOTES:

- Pushrod installation and adjustments must be made when engine is cold. Read instructions thoroughly and follow all recommended steps and procedures.
- If S&S® Standard Adjustable pushrod kit contains four different length pushrods, the longest pushrod is for the front exhaust, next longest is the rear exhaust. Of the two shorter pushrods, the longer one is the front intake, the shortest pushrod is the rear intake. Pushrod kits for 1999–up big twin engines have two different lengths—short for the intakes, long for the exhausts. Pushrod kits for Sportster® models contain four identical pushrods.
- S&S Quickee Pushrods for Harley-Davidson® shovel and Evolution® engines contain two long and two short pushrods. Quickee pushrods for Sportster® models and 1999–up big twins are the same length.
- S&S adjustable pushrods have a thread pitch of 32 threads per inch. This means that one complete turn equals .031" of change in pushrod length and one flat is .005".
- Basic adjustment instructions are for installing S&S adjustable pushrods with the stock-style hydraulic lifters. If the S&S HL2T (Hydraulic Lifter Limiter Travel) kit has been installed in the tappets, pushrod adjustment must be done according to the HL2T instructions.
- To determine if HL2T kit has been installed in the tappets of an assembled engine, compress the hydraulic piston assembly by lengthening the pushrod four complete turns of the pushrod adjuster. After 20 minutes try to spin the pushrod between your fingers. If the pushrod can not be turned with finger pressure, an HL2T kit is installed in the lifters and the HL2T adjustment procedure must be followed. See Section C, Page 3.
- When adjusting Quickee Pushrods, count flats on the 6 sided female adjuster on the pushrod, not the 4 sided male adjusting screw.
- Quickee pushrods for 1966–'84 big twin engines must be used with the S&S hydraulic conversion kit which includes S&S hydraulic tappets and tappet guides. Pushrods with oil holes are for use with S&S rocker arms. Pushrods without oil holes are for stock rocker arms.

- S&S hydraulic lifters have .200" of hydraulic plunger travel. When adjusting pushrods, the plunger should be positioned near the center of its travel. This would be 4 turns or 24 flats which is equal to .125".

CAUTION

- Failure to follow recommended steps and procedures may result in damage to engine components.
- When installed and adjusted, S&S Quickee Pushrods must have a minimum thread engagement of .500" (Pushrod tube to Adjuster, not including the jam nut) or severe damage to the pushrod as well as your engine may occur.
- When adjustment is complete, the jam nut must have full thread engagement with the adjuster screw. If you do not have full engagement, the pushrod is not correct for the application or position.

WARNING

Installing or adjusting pushrods while engine is hot could result in burns from contact with hot engine parts.

Pushrod Installation

1. Remove pushrod cover clips and lift cover assemblies to view tappets.
2. Remove spark plugs and rotate engine until front piston is at the top of its stroke, with both front lifters at their lowest position (TDCC—top dead center compression).

NOTE: To ensure that the piston is at the correct position to remove pushrods, rotate the engine forward and watch the intake pushrod. The intake pushrods are the two closest to the center of the engine. Watch the intake pushrod rise and fall as the engine is rotated. When the intake pushrod is at its lowest position, the piston is on its compression stroke. Check to see if the piston is at TDC. If it isn't, rotate the engine a few more degrees to bring the piston to the top of the cylinder.

3. Remove front pushrods.
 - a. If installing standard adjustable pushrods, disassemble the rocker cover and rocker arm assembly, per the appropriate service manual.
 - b. If installing Quickee pushrods, stock pushrods may be cut out with a bolt cutter to save time. See NOTE and CAUTION below.

NOTE: Since S&S Quickee pushrods do not require rocker arm disassembly for installation, stock pushrods may be cut out of the engine to save time. S&S recommends that they be cut with a bolt cutter.

CAUTION

Do not cut pushrods with a saw, metal chips may enter engine and cause extensive damage not covered by warranty.

WARNING

Make sure tappet is at lowest point of travel and pushrod is not under valve spring pressure before cutting pushrods. Sudden release of valve spring pressure may cause cut pushrods to fly out of motor, potentially causing serious injury.

- Clean and inspect the pushrod tubes. Replace all o-rings. Apply a light coat of engine oil to the o-rings. If using stock pushrod tubes and Quickee pushrods in an Evolution engine, the inner tube should be shortened to avoid contact with pushrod during operation. See **Picture 2**. Shorten the tube according to the following chart:

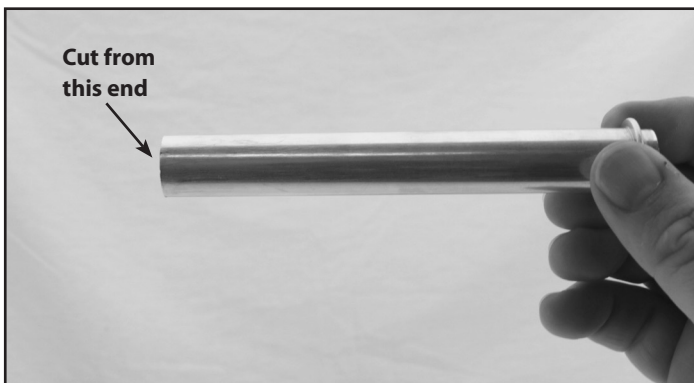

Picture 2

Displacement	Cylinder Length	Final Length of Inner Pushrod Tube
100	4.745	4"
88,107	5.375	4.75"
93,113	5.5	4.875"
80,89,96	5.55	4.875"
98	5.625	5"
103	5.75	5"

- Insert new pushrods through tube assemblies with the adjuster ends down, and install in appropriate positions.
- Reinstall rocker assemblies according to appropriate service manual procedures, if they were removed.

Basic Pushrod Adjustment

- Holding pushrod so the top ball end is in the rocker arm cup, extend adjusting screw until the bottom ball end just contacts the tappet cup. Turn the pushrod adjuster and additional 4 complete turns (24 flats) to compress hydraulic unit in exhaust lifter, and tighten locknut. Allow sufficient time for lifter to bleed down (typically 20 minutes) Pushrods must spin freely with fingers.

Note: With Standard Adjustable Pushrods tighten nut against adjuster sleeve. With S&S Quickee Pushrods, tighten nut against the pushrod body.

- Repeat procedure for Intake pushrod.

NOTE: If pushrods can not be turned between fingers after 20 minutes, tappets contains S&S HL2T spacers. Detailed instructions for the HL2T kit are presented in the next section.



Failure to allow hydraulic unit to bleed down before rotating engine or adjusting the other pushrod could result in valve-to-valve contact and serious valve train damage. Lifters are bled down when pushrod can be turned with fingertips.

- Bring rear piston to Top Dead Center Compression (TDCC) and repeat above procedures for rear cylinder.
- Replace spark plugs and pushrod tube clips. Start motorcycle and check for leaks.

Notes For Sportster® Models

- In order to access the pushrod adjuster screws in 1991 and later Harley-Davidson® Sportster® and Buell® models, it will be necessary to use pushrod cover assembly kit for 1986–'90 Sportster® models, S&S part 93-4038, and the appropriate length pushrod cover keepers. 1991-'03 models will also require pushrod cover adapter kit, S&S part 33-5355.
- On 1991 and later models, it is necessary to disassemble the rocker arm/rocker box to remove the stock one piece pushrod cover.

Notes For Twin Cam 88®, 96™, and 103™ and Milwaukee Eight® Engines

- S&S pushrod kits for the Twin Cam 88®, 96™, and 103™ and Milwaukee Eight® engines are available as a kit containing pushrods only, however, it will be necessary to use S&S pushrod covers, or similar aftermarket product, in order to be able to access the adjuster units on the pushrods. S&S offers kits for stock height 1999–up big twin engines that contain the four adjustable pushrods, pushrod tube set, gaskets and o-rings for a complete assembly.
- If equipped with S&S Easy Start compression release cams, you must use extra care when adjusting pushrods. Because the decompression lobe is near TDC, it is possible to adjust the pushrod while the tappet is on the lobe if it is not exactly at TDC. This will cause incorrect exhaust pushrod adjustment. To verify correct position, you can rotate the engine in the forward direction and feel for the exhaust tappet to slightly lift (about .030") and set back down on the base circle. This is the proper point to adjust the pushrods.
- Once the stock non-adjustable pushrods have been removed, S&S Standard pushrod kits for the Twin Cam 88®, 96™, and 103™ may be installed and removed from the engine without removing the rocker covers. Remove fasteners from tappet covers. Turn the adjusters to make the pushrods as short as possible. Hold the pushrods up against the rocker arm cups and swing pushrods and tappet covers out as an assembly. To install, reverse the process. Insert pushrods through pushrod cover assemblies. Install intake and exhaust pushrod assemblies, along with the tappet cover and new gasket, into position in front cylinder. See **Picture 3**.



Picture 3

Adjusting Pushrods With S&S HL₂T Limited Travel Kit Installed

NOTES:

- The S&S HL₂T kit is designed to limit the travel of the hydraulic lifter making it impossible for the lifter to collapse. Stronger valve springs are often used to avoid valve float at high rpm. The HL₂T kit prevents high valve spring force from collapsing lifters. With the HL₂T kit installed, stock hydraulic lifters work like solid lifters at high rpm, while retaining normal hydraulic function for minimal noise and maintenance under normal conditions. Adjustable pushrods must be used with the HL₂T kit.
- S&S Limited Travel Kit 33-5338 fits all S&S tappets and all Harley-Davidson® replacement tappets for 1999-'17 big twins (18538-99C & 18572-13) and 1991-'17 Sportster® models (18526-89A & 18538-99C).
- S&S Limited Travel kit does not fit Harley-Davidson® replacement tappets (18523-86B) for 1984-'99 big twins and 1986-'90) Sportster® models.
- If using aftermarket tappets, consult the manufacturer to determine compatibility. See Limited Travel washer dimensions below.

KIT	OD	ID
33-5338	.605 OD	.440 ID

HL₂T Kit Installation

1. If tappets are installed in the engine, it is recommended that they be removed. Be sure that each tappet is kept with its original tappet block and bore.

NOTE: This procedure is the preferred method of installation. However, kit can be installed without removing lifters from engine.

2. Remove hydraulic piston retaining wire clip from one assembly at a time.



Be careful not to deform wire clip during disassembly.

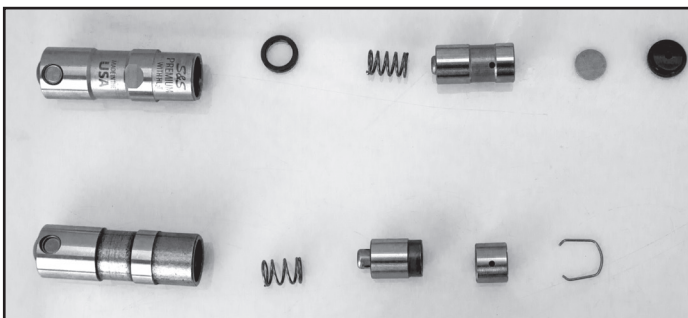

Picture 4

4. Completely disassemble tappet removing all parts.
5. Thoroughly clean all parts including tappet body. Remove any oil which might prevent hydraulic unit from fully collapsing during adjustment.
6. Insert one spacer from S&S HL₂T kit in tappet body.
7. Reassemble tappet in reverse order making sure original parts are returned to their original positions. See **Picture 4**.
8. Replace wire retaining clip in tappet body.
9. Put tappet back in original tappet bore.
10. Repeat Steps 2 through 8 for three remaining tappets.
11. Reassemble engine with modified tappets.

12. Adjust pushrods.

NOTE: In all cases engine must be cold and lifter must be at lowest point of travel for pushrod adjustment.

- a. Remove sparkplugs.
- b. Remove spark plugs and rotate engine until front piston is at the top of its stroke, with both front lifters at their lowest position (TDCC – top dead center, compression).

NOTE: To ensure that the cylinder is at the correct position to adjust pushrods, rotate the engine forward and watch the intake pushrod. The intake pushrods are the two closest to the center of the engine. Watch the intake pushrod rise and fall as the engine is rotated. When the intake pushrod is at its lowest position, the cylinder is on its compression stroke. Check to see if the piston is at TDC. If it isn't, rotate the engine a few more degrees to bring the piston to the top of the cylinder.

- c. Extend one of the front pushrods until it contacts the hydraulic piston assembly in the lifter body, then extend pushrod an additional four complete turns, until piston assembly is in contact with HL₂T spacer and the valve is lifted off of its seat. If tappets contain oil, as when pushrods are readjusted after engine has been run, or if all oil was not removed during installation, allow at least 20–30 minutes for piston assembly to bleed down. If pushrod can be turned between the fingers, tappet piston is not in contact with HL₂T spacer. Lengthen pushrod one additional turn and test again after 20 minutes.
- d. If pushrod can not be turned between the fingers, loosen pushrod adjustment until pushrod can be rotated with the fingers with slight drag. Continue loosening (shortening) pushrod one full turn (6 flats).

NOTE: Shortening adjuster an additional six flats or one full turn from zero lash often results in quieter valve train operation. This provides additional travel for the hydraulic piston assembly, which can improve the ability of the hydraulic unit to maintain zero lash under normal operating conditions.

- e. Tighten lock nut.
- f. Repeat steps c, d, and e for the other front pushrod.
- g. Repeat above procedures for rear cylinder, this time bringing rear piston to TDCC (top dead center compression).
- h. Replace spark plugs and install pushrod clips.

NOTE: Perform this operation on one cylinder at a time. Do not turn engine until pushrod adjustment is complete, and pushrod can be spun with fingers.



Instruction 510-0398

06-30-16

Copyright © 2016

Version 2

by S&S® Cycle, Inc.

All rights reserved.
Printed in the U.S.A.

S&S® Cycle, Inc.

14025 Cty Hwy G PO Box 215

Viola, Wisconsin 54664

Phone: 608-627-1497 • Fax: 608-627-1488

Technical Service Phone: 608-627-TECH (8324)

Technical Service Email: sstech@sscycle.com

Website: www.sscycle.com



Installation Instructions: S&S Hydraulic Cam Chain Tensioners

DISCLAIMER:

Many S&S parts are designed for high performance, closed course, racing applications and are intended for the very experienced rider only. The installation of S&S parts may void or adversely affect your factory warranty. In addition such installation and use may violate certain federal, state, and local laws, rules and ordinances as well as other laws when used on motor vehicles used on public highways. Always check federal, state, and local laws before modifying your motorcycle. It is the sole and exclusive responsibility of the user to determine the suitability of the product for his or her use, and the user shall assume all legal, personal injury risk and liability and all other obligations, duties, and risks associated therewith.

NOT LEGAL FOR SALE OR USE IN CALIFORNIA ON ANY POLLUTION CONTROLLED MOTOR VEHICLES

SAFE INSTALLATION AND OPERATION RULES:

Before installing your new S&S part it is your responsibility to read and follow the installation and maintenance procedures in these instructions and follow the basic rules below for your personal safety.

- Gasoline is extremely flammable and explosive under certain conditions and toxic when breathed. Do not smoke. Perform installation in a well ventilated area away from open flames or sparks.
- If motorcycle has been running, wait until engine and exhaust pipes have cooled down to avoid getting burned before performing any installation steps.
- Before performing any installation steps disconnect battery to eliminate potential sparks and inadvertent engagement of starter while working on electrical components.
- Read instructions thoroughly and carefully so all procedures are completely understood before performing any installation steps. Contact S&S with any questions you may have if any steps are unclear or any abnormalities occur during installation or operation of motorcycle with a S&S part on it.
- Consult an appropriate service manual for your motorcycle for correct disassembly and reassembly procedures for any parts that need to be removed to facilitate installation.
- Use good judgment when performing installation and operating motorcycle. Good judgment begins with a clear head. Don't let alcohol, drugs or fatigue impair your judgment. Start installation when you are fresh.
- Be sure all federal, state and local laws are obeyed with the installation.
- For optimum performance and safety and to minimize potential damage to carb or other components, use all mounting hardware that is provided and follow all installation instructions.
- Motorcycle exhaust fumes are toxic and poisonous and must not be breathed. Run motorcycle in a well ventilated area where fumes can dissipate.

IMPORTANT NOTICE:

Statements in this instruction sheet preceded by the following words are of special significance.



WARNING

Means there is the possibility of injury to yourself or others.

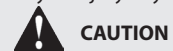

CAUTION

Means there is the possibility of damage to the part or motorcycle.

NOTE

Other information of particular importance has been placed in italic type.

S&S recommends you take special notice of these items.

WARRANTY:

All S&S parts are guaranteed to the original purchaser to be free of manufacturing defects in materials and workmanship for a period of twelve (12) months from the date of purchase. Merchandise that fails to conform to these conditions will be repaired or replaced at S&S's option if the parts are returned to us by the purchaser within the 12 month warranty period or within 10 days thereafter.

In the event warranty service is required, the original purchaser must call or write S&S immediately with the problem. Some problems can be rectified by a telephone call and need no further course of action.

A part that is suspect of being defective must not be replaced by a Dealer without prior authorization from S&S. If it is deemed necessary for S&S to make an evaluation to determine whether the part was defective, a return authorization number must be obtained from S&S. The parts must be packaged properly so as to not cause further damage and be returned prepaid to S&S with a copy of the original invoice of purchase and a detailed letter outlining the nature of the problem, how the part was used and the circumstances at the time of failure. If after an evaluation has been made by S&S and the part was found to be defective, repair, replacement or refund will be granted.

ADDITIONAL WARRANTY PROVISIONS:

- (1) S&S shall have no obligation in the event an S&S part is modified by any other person or organization.
- (2) S&S shall have no obligation if an S&S part becomes defective in whole or in part as a result of improper installation, improper maintenance, improper use, abnormal operation, or any other misuse or mistreatment of the S&S part.
- (3) S&S shall not be liable for any consequential or incidental damages resulting from the failure of an S&S part, the breach of any warranties, the failure to deliver, delay in delivery, delivery in non-conforming condition, or for any other breach of contract or duty between S&S and a customer.

Installation Steps

1. Secure the motorcycle on a lift and elevate the rear tire. Shift transmission into high gear, and remove the spark plugs.
2. Refer to the factory service manual for cam chest disassembly procedure. Remove cam cover, pinion and cam drive sprockets and outer drive chain. Remove the cam support plate, cams, and oil pump.

NOTE - There is no need to remove cams from the cam support plate unless cams are to be changed.

3. If S&S cam chain tensioner units are disassembled for any reason, they should be reassembled according to the part order shown in **Picture 1**.

NOTE - If cam chain tensioners are being reinstalled after engine has been run, all oil must be cleaned out, or installation will be more difficult.

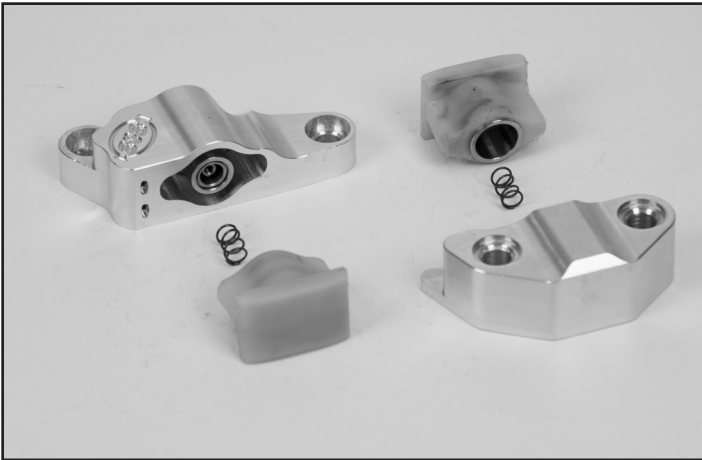

Picture 1

4. Verify that the timing marks on the inner cam sprockets are correctly aligned. Refer to factory service manual or cam installation instructions. See **Picture 2**.

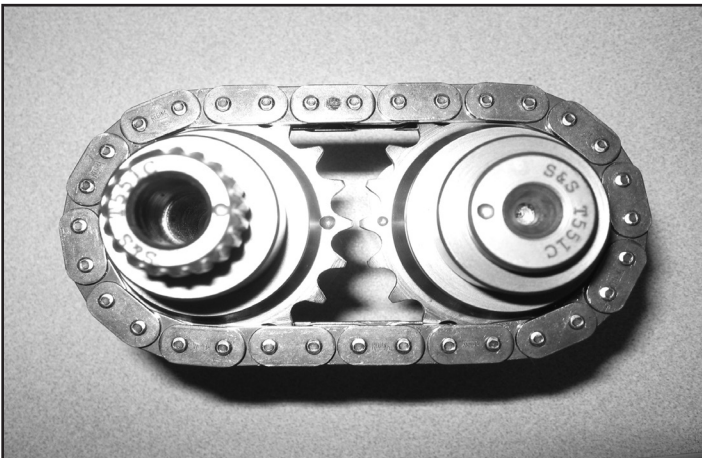

Picture 2

5. Install inner cam chain tensioner assembly. Press the shoe of the tensioner against the chain to compress the spring inside the tensioner assembly. Apply blue thread locker to the 1/4-20 x 1 1/8" Torx-Plus fasteners and install in place of stock hardware. Tighten to 100 in-lb. See **Picture 3**.

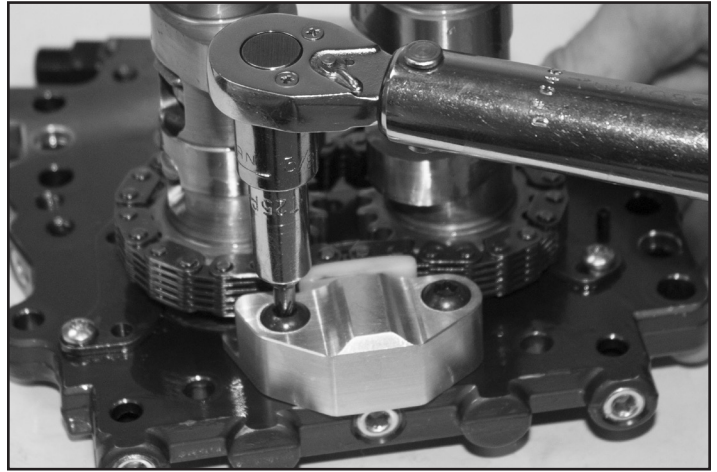

Picture 3

6. Apply engine oil to the supplied oil pump scavenge o-ring, and install in crankcase. Install the oil pump in the crankcase. If installing a new oil pump refer to the instructions supplied with the pump.
7. Apply blue thread locker to existing fasteners and install the cam support plate and cams. Tighten fasteners to 100 in-lb in the sequence shown in **Figure 1**.

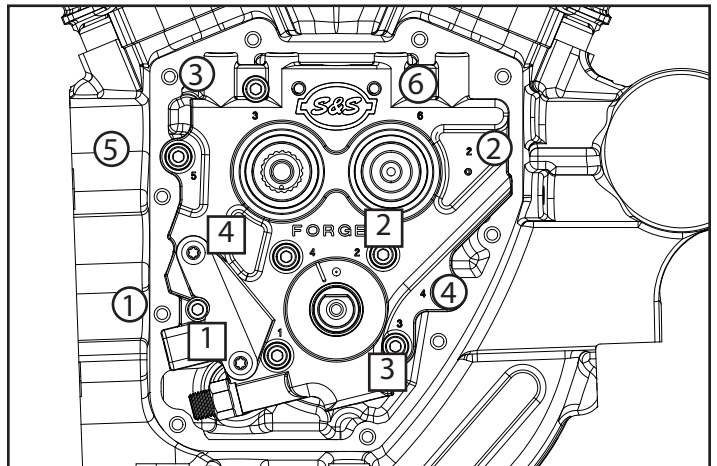

Figure 1

8. Apply blue thread locker to oil pump mounting bolts and install. Do not tighten yet.
9. Refer to **Figure 1** for proper torque sequence. While rotating the engine, alternately tighten bolts 1 and 2 (shown in squares) until the bolts are snug. Tighten bolts 3 and 4 until they are snug. Finally, torque the four bolts in the sequence shown to 100 in-lbs. This procedure ensures that the oil pump is properly centered.
10. Install spacer over the end of the rear cam, and install the rear cam drive sprocket, and hand tighten the bolt.
11. Install the pinion sprocket and hand tighten the bolt.
12. Insert a sprocket locking tool and tighten both bolts to 15 ft-lb.

13. Push both sprockets toward the left side of the motorcycle to take up any end play. Lay a straight edge over the sprocket faces to determine correct sprocket alignment. If the gap between the straight edge and the lower of the sprockets is less than .010", no adjustment is necessary. If sprockets are out of alignment by more than .010" a different spacer must be installed so the sprockets are in line. Refer to factory service manual.

14. Remove both sprockets.

15. Install outer drive chain and sprockets. Make sure the timing marks on the pinion and rear cam drive sprocket are lined up. **Picture 4** shows 2007-'16 style chain and sprockets. **Picture 5** shows the 1999-'06 style "silent" chain and sprockets. Stock early chains and sprockets may be used with S&S hydraulic cam chain tensioners when also installing an S&S cam support plate.

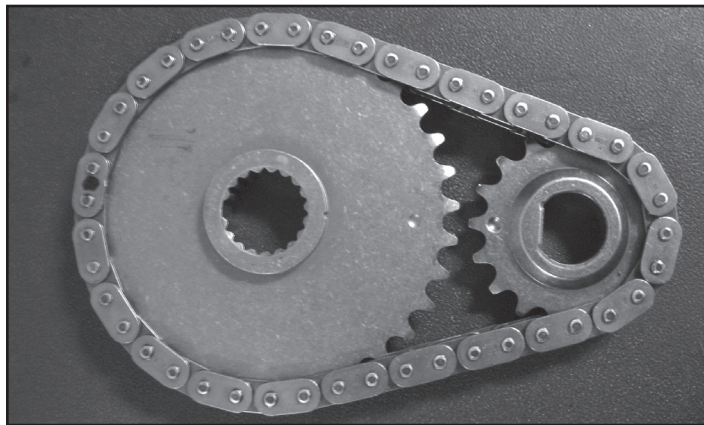

Picture 4

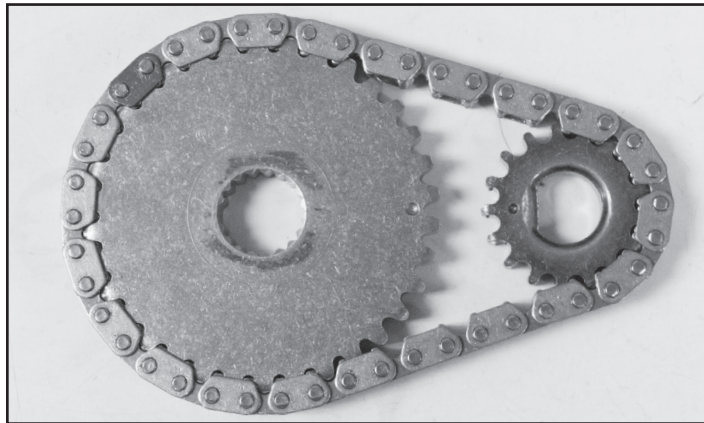

Picture 5

16. Insert sprocket locking tool. Apply blue thread locker to the bolts and tighten the pinion sprocket bolt to 25 ft-lb and the cam sprocket bolt to 34 ft-lb.

17. Apply blue thread locker to the two 1/4-20 x 3/4" Torx head bolts, and install the outer chain tensioner loosely with one bolt. Press the tensioner shoe against the drive chain to compress the spring inside the tensioner. Install the second bolt, and tighten both bolts to 100 in-lb. **See Picture 6.**

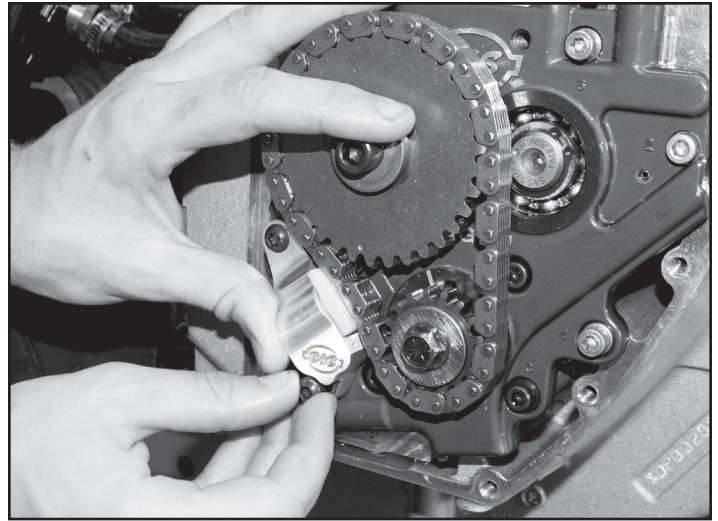

Picture 6

18. Place clay or putty on the inside of the cam cover in the area near the outer hydraulic chain tensioner, and install on cam chest with the intended gasket. Remove and inspect the amount of clearance between the cam chain tensioner and the cam cover. If necessary, grind material from the cover to provide a minimum of .030" clearance. This check is especially important when converting 1999-'06 engines from spring loaded chain tensioners to hydraulic tensioners, and for engines with aftermarket cam covers.

19. Reassemble the cam chest and pushrods using the procedure in the factory service manual or instructions supplied with any aftermarket components used.

