



Assembly Instructions: Grand National Slip-on Mufflers for 2015-2023 Indian Scout (part number 4110-266-R)

DISCLAIMER:

Many S&S parts are designed for high performance, closed course, racing applications and are intended for the very experienced rider only. The installation of S&S parts may void or adversely affect your factory warranty. In addition such installation and use may violate certain federal, state, and local laws, rules and ordinances as well as other laws when used on motor vehicles used on public highways. Always check federal, state, and local laws before modifying your motorcycle. It is the sole and exclusive responsibility of the user to determine the suitability of the product for his or her use, and the user shall assume all legal, personal injury risk and liability and all other obligations, duties, and risks associated therewith.

DISCLAIMER: FOR CLOSED COURSE COMPETITION USE ONLY. NOT INTENDED FOR STREET USE. LEGAL IN CALIFORNIA ONLY FOR RACING VEHICLES WHICH MAY NEVER BE USED, OR REGISTERED OR LICENSED FOR USE, UPON A HIGHWAY. NOT LEGAL FOR SALE OR USE NATIONWIDE ON ANY FEDERAL POLLUTION CONTROLLED MOTOR VEHICLE UNDER THE CLEAN AIR ACT.

SAFE INSTALLATION AND OPERATION RULES:

Before installing your new S&S part, it is your responsibility to read and follow the installation and maintenance procedures in these instructions and follow the basic rules below for your personal safety.

- Gasoline is extremely flammable and explosive under certain conditions and toxic when breathed. Do not smoke. Perform installation in a well ventilated area away from open flames or sparks.
- If motorcycle has been running, wait until engine and exhaust pipes have cooled down to avoid getting burned before performing any installation steps.
- Before performing any installation steps, disconnect battery to eliminate potential sparks and inadvertent engagement of starter while working on electrical components.
- Read instructions thoroughly and carefully so all procedures are completely understood before performing any installation steps. Contact S&S with any questions you may have if any steps are unclear or any abnormalities occur during installation or operation of motorcycle with an S&S part on it.
- Consult an appropriate service manual for your motorcycle for correct disassembly and reassembly procedures for any parts that need to be removed to facilitate installation.
- Use good judgment when performing installation and operating motorcycle. Good judgment begins with a clear head. Don't let alcohol, drugs or fatigue impair your judgment. Start installation when you are fresh.
- Be sure all federal, state and local laws are obeyed with the installation.
- For optimum performance and safety and to minimize potential damage to carb or other components, use all mounting hardware that is provided and follow all installation instructions.
- Motorcycle exhaust fumes are toxic and poisonous and must not be breathed. Run motorcycle in a well ventilated area where fumes can dissipate.

IMPORTANT NOTICE:

Statements in this instruction sheet preceded by the following words are of special significance.

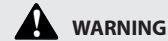

WARNING

Means there is the possibility of injury to yourself or others.



CAUTION

Means there is the possibility of damage to the part or motorcycle.

NOTE

Other information of particular importance has been placed in italic type.

S&S recommends you take special notice of these items.

WARRANTY:

All S&S parts are guaranteed to the original purchaser to be free of manufacturing defects in materials and workmanship for a period of twelve (12) months from the date of purchase. Merchandise that fails to conform to these conditions will be repaired or replaced at S&S's option if the parts are returned to us by the purchaser within the 12 month warranty period or within 10 days thereafter.

In the event warranty service is required, the original purchaser must call or write S&S immediately with the problem. Some problems can be rectified by a telephone call and need no further course of action.

A part that is suspect of being defective must not be replaced by a Dealer without prior authorization from S&S. If it is deemed necessary for S&S to make an evaluation to determine whether the part was defective, a return authorization number must be obtained from S&S. The parts must be packaged properly so as to not cause further damage and be returned prepaid to S&S with a copy of the original invoice of purchase and a detailed letter outlining the nature of the problem, how the part was used and the circumstances at the time of failure. If after an evaluation has been made by S&S and the part was found to be defective, repair, replacement or refund will be granted.

ADDITIONAL WARRANTY PROVISIONS:

- (1) S&S shall have no obligation in the event an S&S part is modified by any other person or organization.
- (2) S&S shall have no obligation if an S&S part becomes defective in whole or in part as a result of improper installation, improper maintenance, improper use, abnormal operation, or any other misuse or mistreatment of the S&S part.
- (3) S&S shall not be liable for any consequential or incidental damages resulting from the failure of an S&S part, the breach of any warranties, the failure to deliver, delay in delivery, delivery in non-conforming condition, or for any other breach of contract or duty between S&S and a customer.

TOOLS REQUIRED

- Safety Glasses
- Hammer, Soft Face
- Platform Jack, Motorcycle
- Socket Set, Hex Bit, Metric

- Socket Set, Hex Bit, Metric, Ball-End
- Socket Set, Metric
- Torque Wrench

INSTALLATION INSTRUCTIONS

VEHICLE PREPARATION

GENERAL

1. Park motorcycle on a flat surface, fully extend kickstand, and make sure vehicle is stable.
2. Turn key or ignition switch to OFF position and remove key. If equipped with keyless fob, remove fob from proximity of vehicle.



WARNING



Make sure exhaust is cooled before starting removal.

MUFFLER REMOVAL

1. Remove RH saddlebag (if equipped).
2. Loosen nuts (A) on muffler clamps at front of each muffler until clamps slide freely.

NOTICE: Make note of clamp orientation for reinstallation.

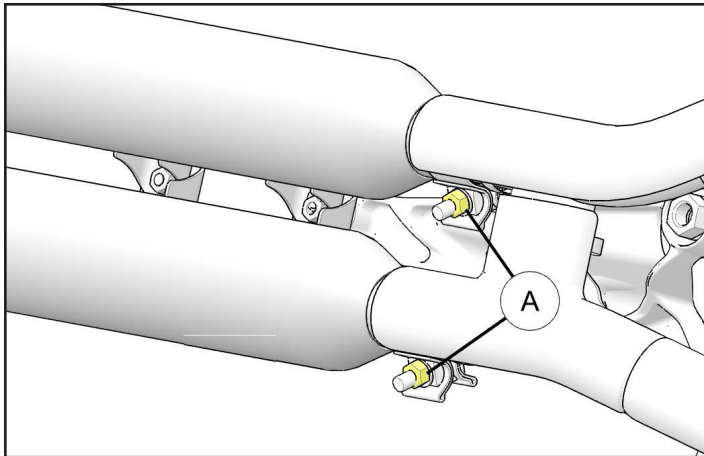

3. Remove bolt (B) at rear of exhaust assembly connecting upper and lower mufflers together.

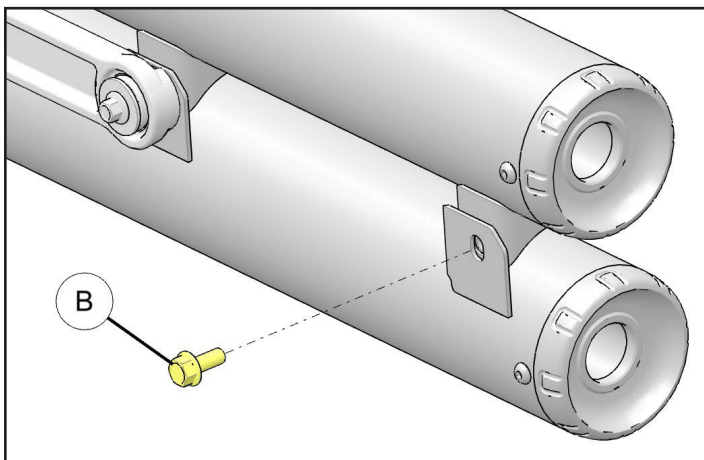

4. Remove two bolts (C) washers (D) (if installed) and exhaust isolators (E) (if installed) connecting upper muffler to exhaust mount.

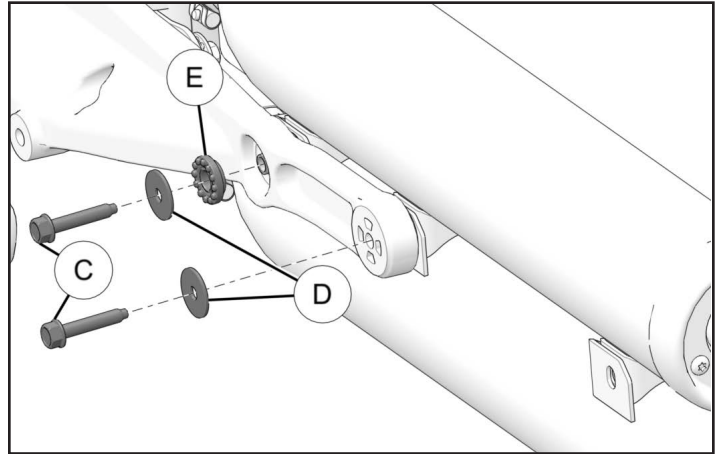

5. Remove upper muffler (F) by gently moving muffler up and down and side to side while sliding muffler assembly rearward.

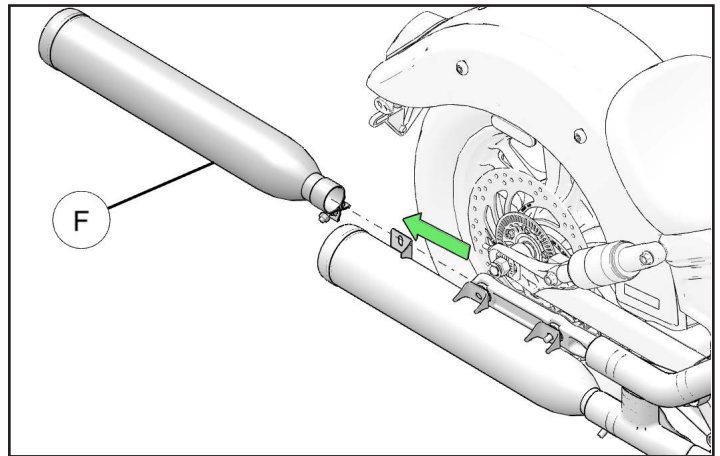

6. Remove lower muffler (G) by gently moving muffler up and down and side to side while sliding muffler assembly rearward.

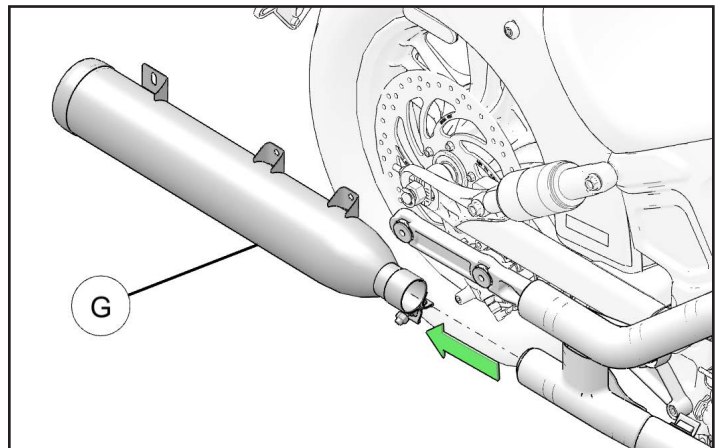

ACCESSORY INSTALLATION

1. Transfer both exhaust clamps from stock mufflers to new mufflers.
2. Install lower muffler onto rear head pipe assembly while loosely installing muffler clamp.

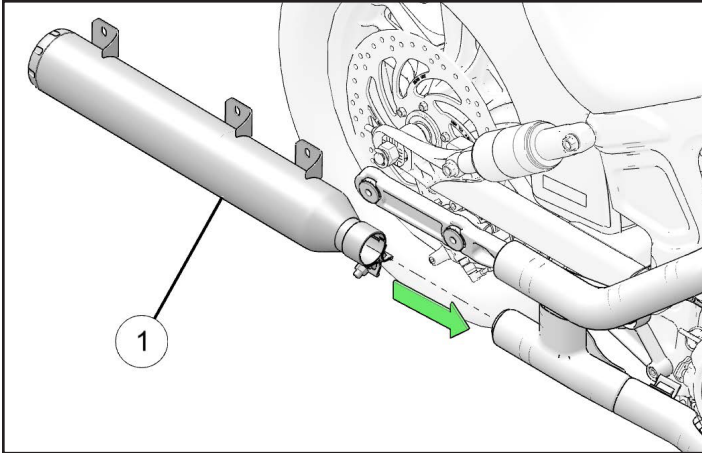

3. Install upper muffler onto rear head pipe assembly while loosely installing muffler clamp.

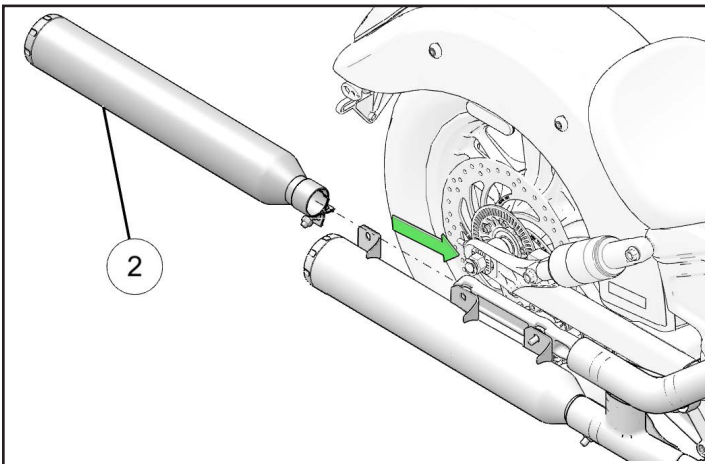

4. Loosely install retained bolts (C), washers (D) and exhaust isolators (E) into recess in exhaust mount and loosely install bolt (C) to secure lower muffler to exhaust mount.

DO NOT torque fasteners at this time.

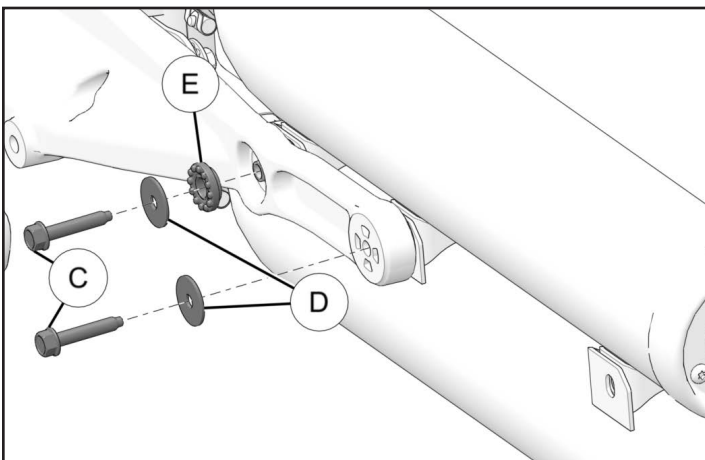

5. Loosely install bolt (B) to secure upper and lower mufflers together.

DO NOT torque fasteners at this time.

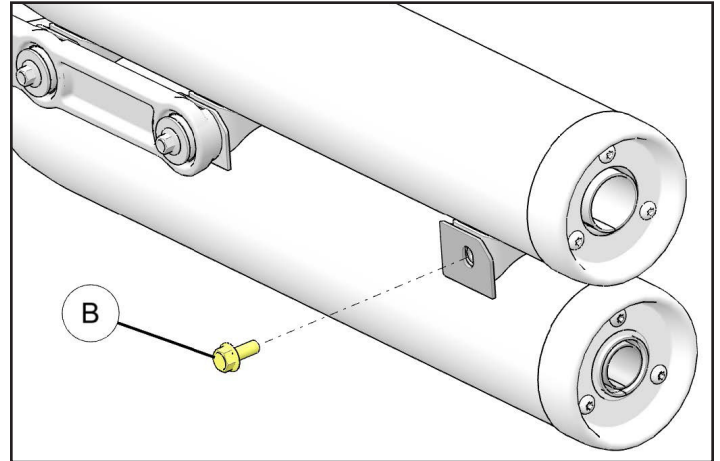

6. Make sure mufflers are properly aligned, torque bolts (B) and (C). Then torque nuts (A) on muffler clamps. Ensure clamp orientation is correct.

TORQUE

Muffler Mount Bolts (B) and (C): 19 ft-lbs (25 N·m)

TORQUE

Muffler Clamp Nuts (A): 40 ft-lbs (54 N·m)

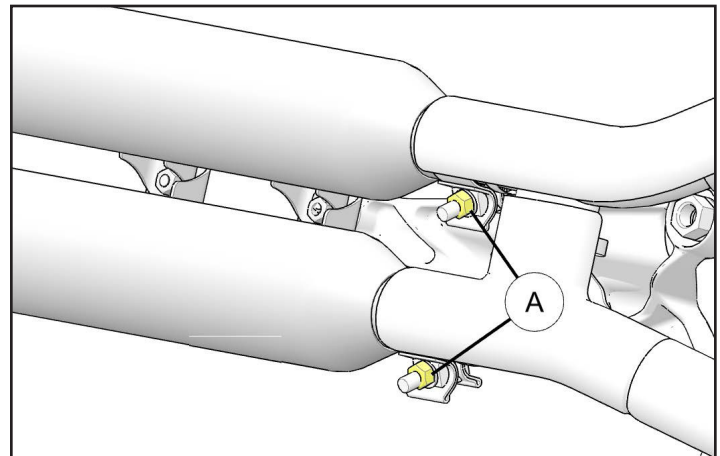

7. Reinstall right-hand saddlebag (if removed).

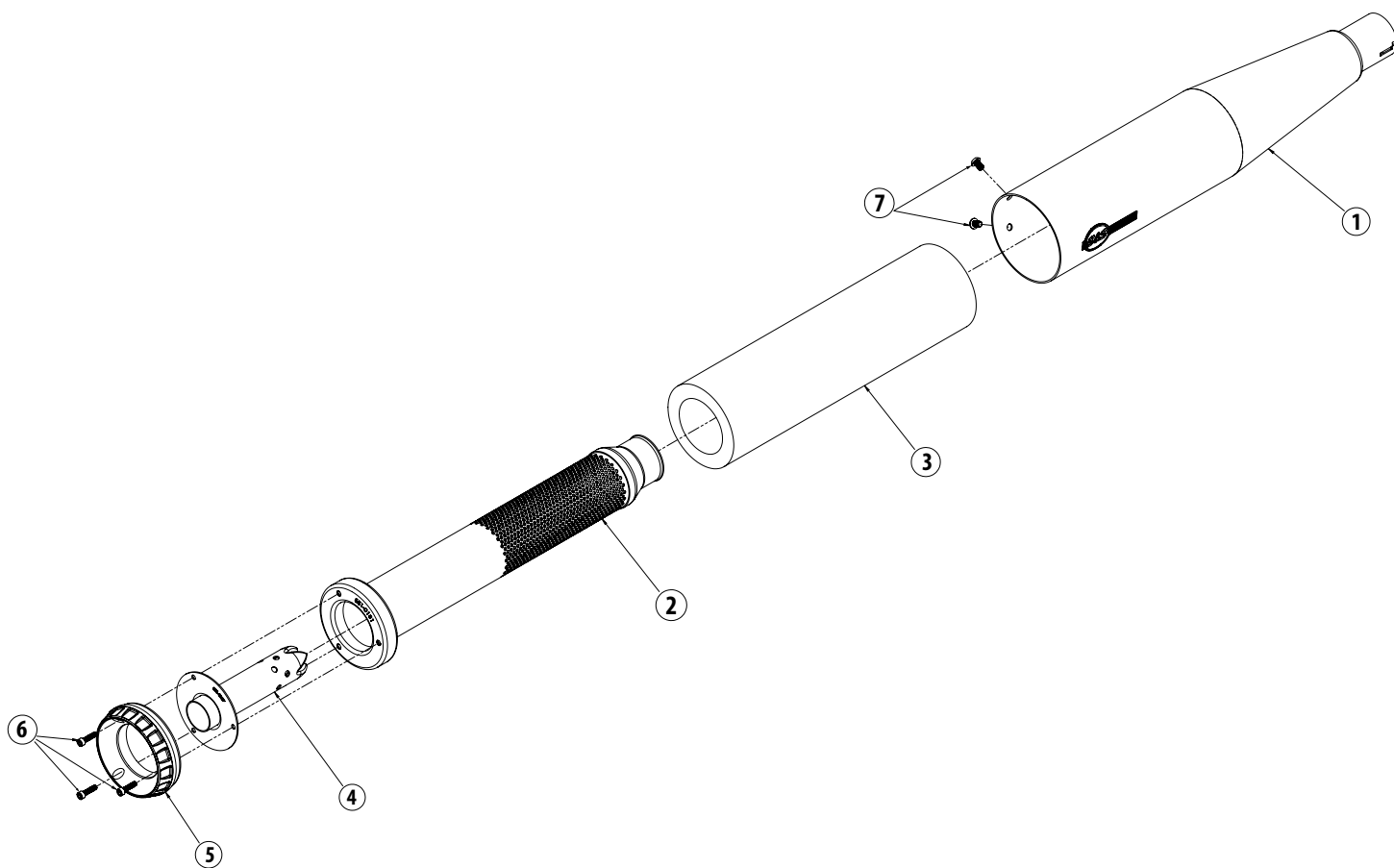

Replcement Parts

1. Muffler, Assembly, Top, 4", Black, 2020 Indian Scout	551-0843B-R
2. Baffle, Assembly, Race Only, Weldment, 2020 Indian Scout	551-0824A-R
3. Insulation, Muffler, Pillow Pack, Ø3.8 OD X 14"	551-0819
4. Baffle, Assembly, Muffler, 10 X 1/4" Hole, SAE J2825, 1.375"	551-0838
5. Cap, End, Muffler, Grand National, Powdercoated, 4", Black	551-0291
6. Screw, SHC, High Temp Lock Patch, 10-32 x 3/4", Stainless Steel	500-0569
7. Screw, BHC, High Temp Lock Patch, 1/4-20 x 3/8", Stainless Steel	500-0441