

**Instruction 51-1116
10-19-11**

Copyright © 2008, 2011
by S&S Cycle, Inc.

All rights reserved.
Printed in the U.S.A.

S&S® Cycle, Inc.

14025 Cty Hwy G PO Box 215
Viola, Wisconsin 54664

Phone: 608-627-1497 • Fax: 608-627-1488

Technical Service Phone: 608-627-TECH (8324)

Technical Service Email: sstech@sscycle.com

Website: www.sscycle.com



Installation Instructions: S&S® 4" and 4 1/8" Bore Hot Set Up Kits® for Harley-Davidson® Twin Cam 88® Engines

DISCLAIMER:

S&S parts are designed for high performance, closed course, racing applications and are intended for the very experienced rider only. The installation of S&S parts may void or adversely affect your factory warranty. In addition such installation and use may violate certain federal, state, and local laws, rules and ordinances as well as other laws when used on motor vehicles used on public highways, especially in states where pollution laws may apply. Always check federal, state, and local laws before modifying your motorcycle. It is the sole and exclusive responsibility of the user to determine the suitability of the product for his or her use, and the user shall assume all legal, personal injury risk and liability and all other obligations, duties, and risks associated therewith.

The words Harley®, Harley-Davidson®, H-D®, Sportster®, Evolution®, and all H-D part numbers and model designations are used in reference only. S&S Cycle is not associated with Harley-Davidson, Inc.

SAFE INSTALLATION AND OPERATION RULES:

Before installing your new S&S part it is your responsibility to read and follow the installation and maintenance procedures in these instructions and follow the basic rules below for your personal safety.

- Gasoline is extremely flammable and explosive under certain conditions and toxic when inhaled. Do not smoke. Perform installation in a well ventilated area away from open flames or sparks.
- If motorcycle has been running, wait until engine and exhaust pipes have cooled down to avoid getting burned before performing any installation steps.
- Before performing any installation steps disconnect battery to eliminate potential sparks and inadvertent engagement of starter while working on electrical components.
- Read instructions thoroughly and carefully so all procedures are completely understood before performing any installation steps. Contact S&S with any questions you may have if any steps are unclear or any abnormalities occur during installation or operation of motorcycle with a S&S part on it.
- Consult an appropriate service manual for your motorcycle for correct disassembly and reassembly procedures for any parts that need to be removed to facilitate installation.
- Use good judgment when performing installation and operating motorcycle. Good judgment begins with a clear head. Don't let alcohol, drugs or fatigue impair your judgment. Start installation when you are fresh.
- Be sure all federal, state and local laws are obeyed with the installation.
- For optimum performance and safety and to minimize potential damage to carb or other components, use all mounting hardware that is provided and follow all installation instructions.
- Motorcycle exhaust fumes are toxic and poisonous and must not be inhaled. Run motorcycle in a well ventilated area where fumes can dissipate.

IMPORTANT NOTICE:

Statements in this instruction sheet preceded by the following words are of special significance.



WARNING

Means there is the possibility of injury to yourself or others.

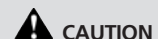

CAUTION

Means there is the possibility of damage to the part or motorcycle.

NOTE

Other information of particular importance has been placed in italic type.

S&S recommends you take special notice of these items.

WARRANTY:

All S&S parts are guaranteed to the original purchaser to be free of manufacturing defects in materials and workmanship for a period of twelve (12) months from the date of purchase. Merchandise that fails to conform to these conditions will be repaired or replaced at S&S's option if the parts are returned to us by the purchaser within the 12 month warranty period or within 10 days thereafter.

In the event warranty service is required, the original purchaser must call or write S&S immediately with the problem. Some problems can be rectified by a telephone call and need no further course of action.

A part that is suspect of being defective must not be replaced by a Dealer without prior authorization from S&S. If it is deemed necessary for S&S to make an evaluation to determine whether the part was defective, a return authorization number must be obtained from S&S. The parts must be packaged properly so as to not cause further damage and be returned prepaid to S&S with a copy of the original invoice of purchase and a detailed letter outlining the nature of the problem, how the part was used and the circumstances at the time of failure. If after an evaluation has been made by S&S and the part was found to be defective, repair, replacement or refund will be granted.

ADDITIONAL WARRANTY PROVISIONS:

- (1) S&S shall have no obligation in the event an S&S part is modified by any other person or organization.
- (2) S&S shall have no obligation if an S&S part becomes defective in whole or in part as a result of improper installation, improper maintenance, improper use, abnormal operation, or any other misuse or mistreatment of the S&S part.
- (3) S&S shall not be liable for any consequential or incidental damages resulting from the failure of an S&S part, the breach of any warranties, the failure to deliver, delay in delivery, delivery in non-conforming condition, or for any other breach of contract or duty between S&S and a customer.
- (4) S&S parts are designed exclusively for use in Harley-Davidson® and other American v-twin motorcycles. S&S shall have no warranty or liability obligation if an S&S part is used in any other application.

INTRODUCTION

Installation of S&S® 4" and 4½" bore Hot Set Up Kits® for Harley-Davidson® Twin Cam 88® engines is relatively straight forward. Other than machining the crankcases to accept the larger spigots of the big bore cylinders, assembly procedures for S&S Hot Set Up Kits® are essentially the same as for assembly of a stock engine. S&S sells a special boring fixture which allows any automotive machine shop to do this modification quickly and accurately. In addition a torque plate kit for boring and honing S&S big bore cylinders is available.

NOTES

- S&S 100" Hot Set Up Kits for Twin Cam 88® engines are designed so that the stock 4" stroke flywheel assembly from an 88" or 95" engine can be used without rebalancing.
- The 107", 116" and 124" kits require stroker flywheels which are included with the kit. S&S flywheels are supplied assembled and balanced. The procedure for installing an S&S flywheel assembly is the same as for stock flywheels.
- When assembling crankcases that have been bored to accept big bore cylinders, use S&S torque specifications for crankcase bolts. See Figure 1.

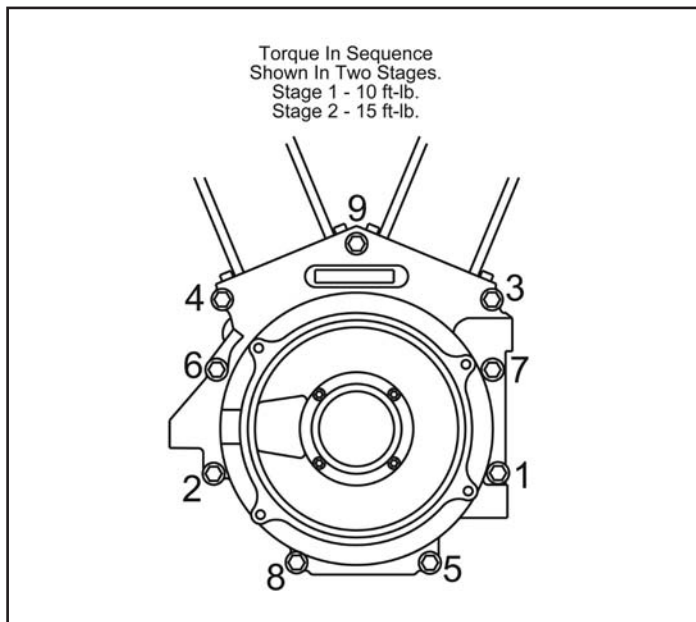

Figure 1

- All instructions are the same, specifics for the 124" kit will be called out separately.

INSTALLATION STEPS

1. Prepare right side crankcase.
2. Bore crankcases for S&S big bore cylinders.
3. Check frame clearances
4. Check internal engine clearances and assemble crankcases.
5. Final assembly.
6. Engine break-in procedure.

INSTALLATION

1. Prepare Camside Crankcase

- A. Remove engine from frame. Disassemble engine and split crankcases.
- B. Temporarily install cams to be used in camside crankcase. Refer to S&S cam installation instructions. Turn cams at least one full rotation, and note any clearance problems between the cam lobes and the crankcase. Pay particular attention to pinion bearing boss and tappet guide boss areas.
- C. Grind or machine material from crankcase to achieve .030" clearance between cam lobes and crankcase. See Picture 1 & 2.

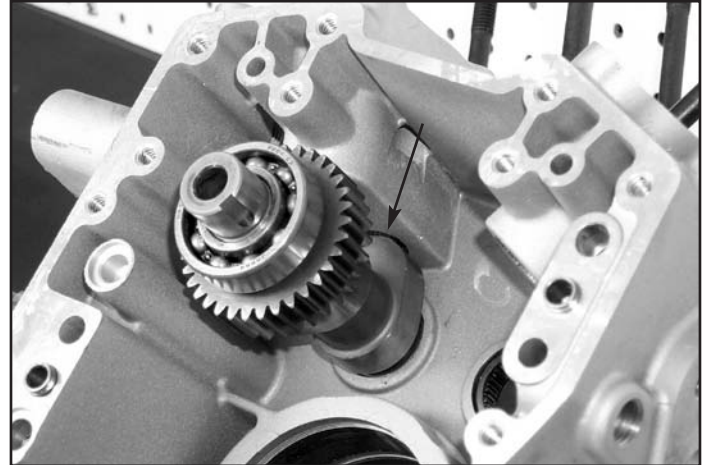

Picture 1

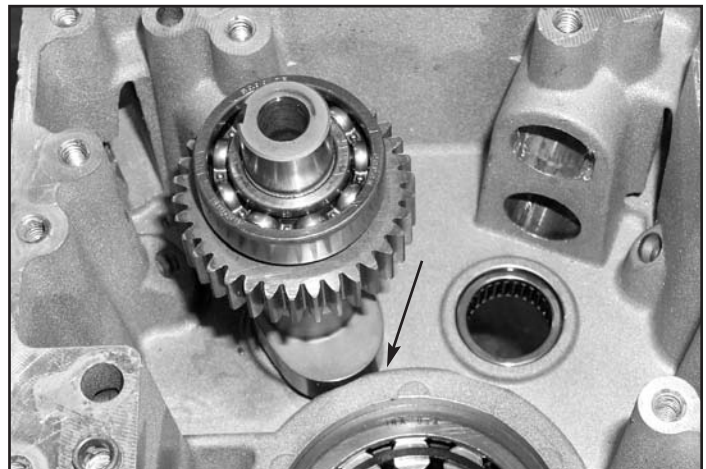

Picture 2

Clearance between cam lobes and crankcase must be checked at pinion bearing boss, and tappet guide boss. Grind or machine case to achieve .030" minimum clearance.

NOTE: On 2003 and up Harley-Davidson® cases you must use the Bearing Kit H-D® #24004-03B on the sprocket shaft.

All reference to Harley-Davidson® part numbers is for identification purposes only. We in no way are implying that any of S&S® Cycle's products are original equipment parts or that they are equivalent to the corresponding Harley-Davidson® part number shown.

D. Modify crankcase for special S&S® center case bolt.

1. Place crankcase halves together and place on table of drill press or milling machine with driveside case up. Using drive side center case bolt hole as a guide, drill $\frac{1}{32}$ " hole all the way through to outside of camside crankcase. See **Picture 3**.



Picture 3

2. Place camside crankcase half on table of drill press or milling machine. Spot face the area around the newly drilled center crankcase bolt hole on the outside of the camside crankcase. Spot face diameter to be $.615 \pm .010$ ". Spot facing can be done with a $\frac{1}{2}$ " piloted spot facing tool, a long $\frac{5}{8}$ " end mill, or a small boring bar in a milling machine. See **Picture 4**.



Picture 4

- E. Remove cam bearings, pinion bearing and piston oilers. Seal off piston oiler holes with a small piece of tape.

2. Crankcase Boring Procedure

The cylinder spigot holes of Harley-Davidson® Twin Cam 88® crankcases must be bored to a larger diameter to accept S&S big bore cylinders. The instructions for this step describe two methods of boring cylinder spigot holes. The first method requires a boring bar and the S&S boring fixture and spacer.

The second procedure describes how cases can be bored on a milling machine if the S&S boring fixture and spacer are not available.

Bore Crankcases Using S&S Boring Fixture

CAUTION

This operation should be performed by an experienced machinist. Dimensions of spigot bore are critical. Crankcases may be ruined if machining is not done correctly.

- A. Bolt crankcases together as an assembly. Use special S&S center case bolt with special washers installed in the order shown in **Picture 5**. Torque case bolts in two stages to 10 ft-lb. and finally 15 ft-lb. in the sequence shown in **Figure 1**.



Picture 5

- B. Install crankcase on boring table using S&S boring plate for Twin Cam 88® 53-0036 and S&S boring spacer 53-0037. Torque nuts on cylinder studs to 35 – 40 ft-lb. See **Picture 6**.

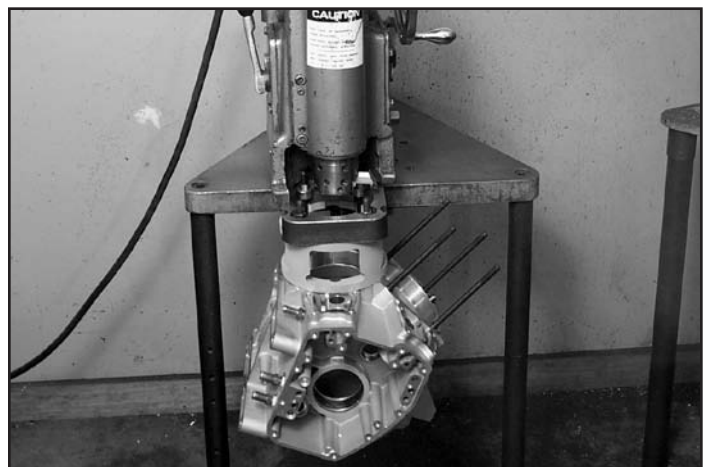

Picture 6

- C. Center boring bar in cylinder spigot bore and set cutters to 4.075" diameter for 4" bore. For 4½" bore set cutters to 4.162".
- D. **Bore spigot hole approximately 2.250" deep**, stopping before contacting cam bearing boss. Spigot bore diameter can be checked with dial caliper through window in boring spacer. See **Picture 7**.

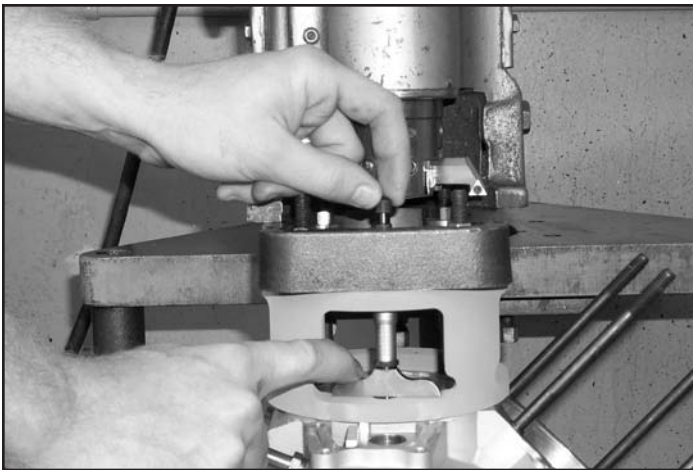

Picture 8

- G. Deburr machined surfaces. Remove weak projecting piece of metal below center case bolt hole on inside of both crankcase halves. See **Picture 9**. Thoroughly clean all parts.

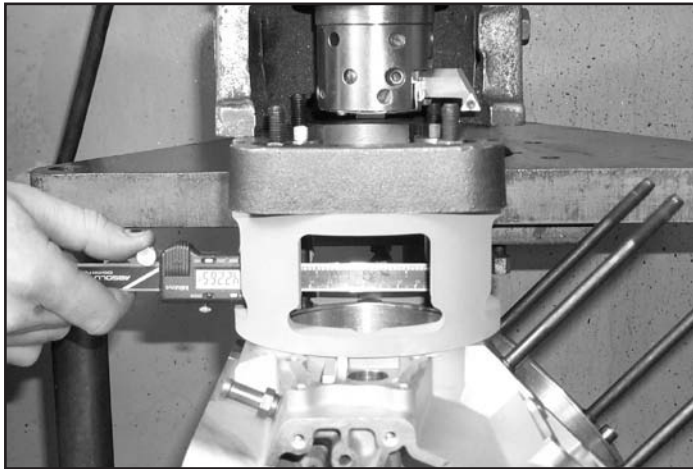

Picture 7

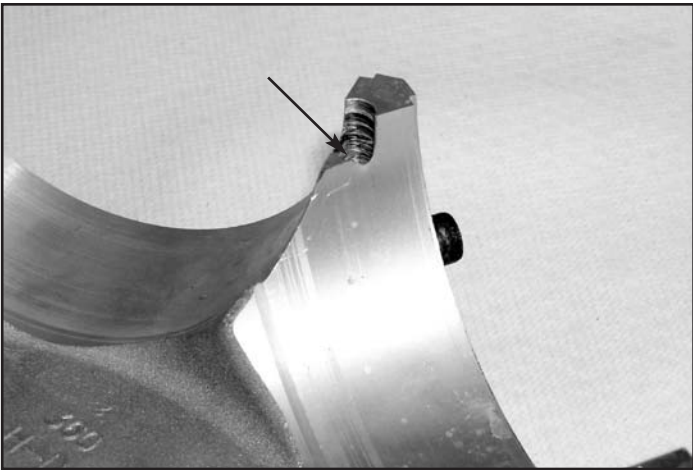

Picture 9

CAUTION

If cylinder spigot holes are bored deeper than 1.550" they may break into oil return passage in crankcase. See Figure 2.

- E. **NOTE: 124" measurements require a depth of 1.545" and a final diameter of 4.322"**. Increasing cutter diameter in increments of approximately .050", make 4 cuts to a depth of 1.550" from crankcase cylinder deck surface, with a final diameter of 4.255".
- F. See **Figure 2**. Spigot bore depth can be measured with depth micrometer through window in boring spacer. See **Picture 8**.

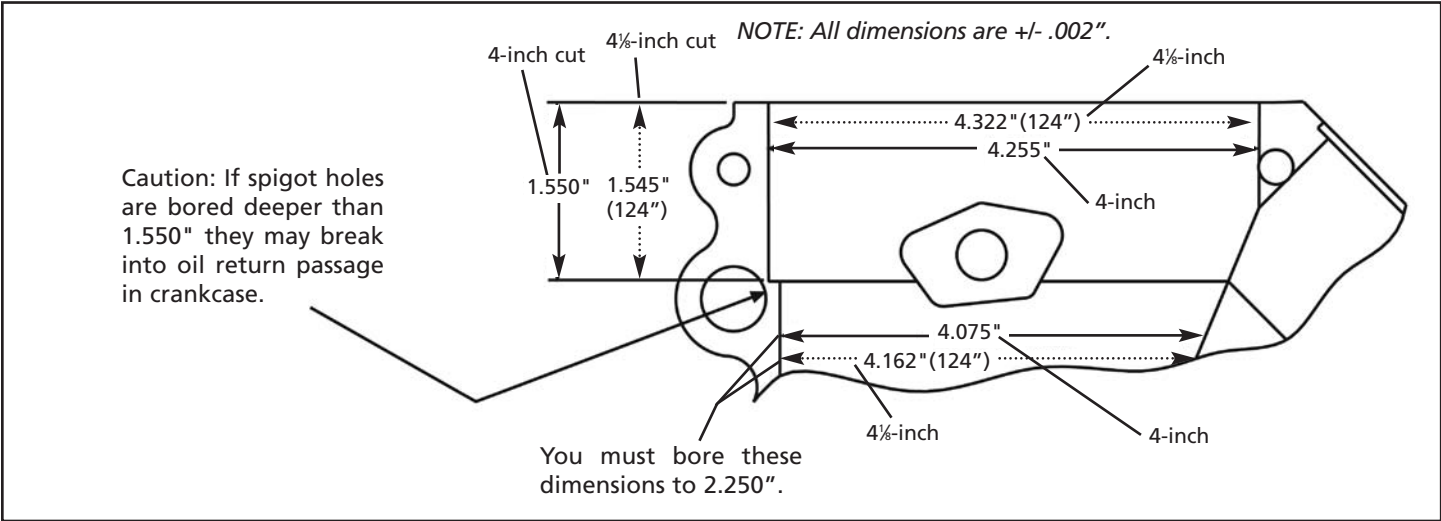

Figure 2

124" Cylinder Stud Installation

- A. Clean the case area surrounding the studs thoroughly.
- B. Run a $\frac{3}{8}$ " nut $\frac{2}{3}$ of the way down the threads of the stud and then run a second nut down to lock it in place.
- C. Put an open-end wrench on the bottom nut and turn it to the left (loosening direction). Since it is locked in place by the second $\frac{3}{8}$ " nut it will twist the stud out of the case. Repeat process for remaining studs.
- D. Once all the studs are out, clean the threaded area with compressed air or a mild solvent if needed.
- E. Next, carefully run the new S&S® studs (31-2325) into the cases to confirm there are no burrs in the case.
- F. Remove all 8 studs and inspect the condition of the threads. Working with one stud at a time, apply red 262 Loctite® to the threads.
- G. Using the same 2-nut method as above, torque the stud to 10ft-lbs. Repeat this process for the other 7 studs.

Piston Oilers and Pinion Bearings

- A. Install Special S&S piston oilers and new pinion and cam bearings. – Follow Harley-Davidson® factory procedures.

NOTE: Cam bearings must be Torrington® B-148 full complement bearing (S&S Part 31-4080), or equivalent. We do not recommend using stock Harley-Davidson® cam bearings.

Bore Crankcases Using Milling Machine

CAUTION

This operation should be performed by an experienced machinist. Dimensions of spigot bore are critical. Crankcases may be ruined if machining is not done correctly.

- A. Remove cylinder studs. This can generally be done fairly easily by double nutting studs and removing with a wrench.
- B. Bolt crankcases together as in assembly. Use special S&S center case bolt with special washers installed in the order shown. Torque case bolts in two stages to 10 ft-lb. and finally 15 ft-lb. in the sequence shown in Figure 1.
- C. Using a large right angle plate, mount crankcase on milling machine with the camside case toward the right angle plate. Cam plate locating dowels make it necessary to space crankcase away from the right angle plate using parallel bars or similar spacers. We recommend that the crankcase be attached to plate with a stud through the plate. The stud should extend through the pinion bearing hole to a flat plate inside the crankcase on the pinion bearing boss. Crankcase is clamped to the angle plate by tightening a nut behind the flat plate. We also recommend that external clamps be used to insure that the crankcases do not shift during the machining operation. A sprocket shaft installation tool makes a convenient plate to prevent the case from being damaged by the clamp. See Pictures 10 & 11.

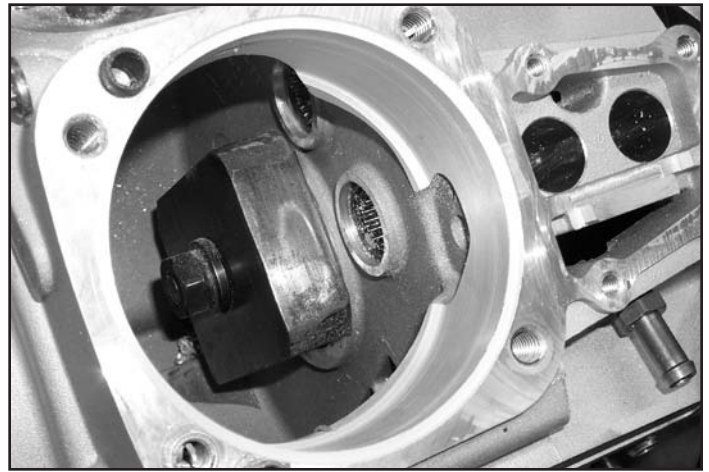

Picture 10

Bolt crankcases to angle plate using a flat plate inside the crankcase on the pinion bearing boss.

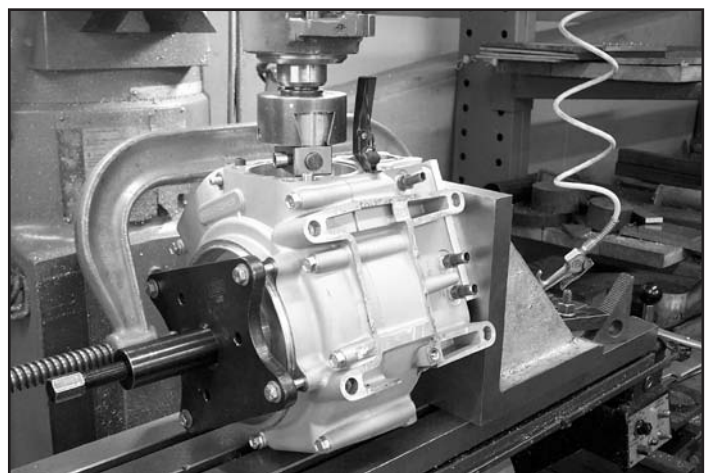

Picture 11

Extra clamping prevents cases from shifting during machining operation.

- D. Level crankcases by eye. Cases do not have to be perfectly level with the table of the mill because the head of the milling machine will be aligned to the crankcase cylinder base surface.
- E. Using quill mounted indicator or dial indicator mounted in a collet, indicate cylinder base surface of crankcase in both axes. Align mill head to crankcase cylinder base surface using the mill head pivot adjustments.

NOTE: Since case cylinder base surface is true with respect to the mill head, but may not be true with respect to mill table, boring must be done by lowering the spindle. If table is raised to bore cases, resulting bores may not be true with respect to case cylinder base surface.

CAUTION

If cylinder spigot holes are bored deeper than 1.550" they may break into oil return passage in crankcase. See Figure 2.

- F. Center mill in bore of crankcase spigot hole, and set cutter to 4.075" diameter for 4" bore. For 4 $\frac{1}{8}$ " bore set cutters to 4.162".
- G. **Bore spigot hole approximately 2.250" deep**, stopping before contacting cam bearing boss.
- H. **NOTE: 124" measurements require a depth of 1.545" and a final diameter of 4.322"**. Increasing cutter diameter in increments of approximately .050", make 4 cuts to a depth of 1.550" from crankcase cylinder deck surface with a final diameter of 4.255".
- I. Repeat procedure for other cylinder spigot hole.
- J. Debur machined surfaces. Remove weak projecting piece of metal below center case bolt hole on inside of both crankcase halves. **See Picture 9**. Thoroughly clean all parts.

124ci Cylinder Stud Installation

- A. Clean the case area surrounding the studs thoroughly.
- B. Run a $\frac{3}{8}$ " nut $\frac{2}{3}$ of the way down the threads of the stud and then run a second nut down to lock it in place.
- C. Put an open-end wrench on the bottom nut and turn it to the left (loosening direction). Since it is locked in place by the second $\frac{3}{8}$ " nut it will twist the stud out of the case. Repeat process for remaining studs.
- D. Once all the studs are out, clean the threaded area with compressed air or a mild solvent if needed.
- E. Next, carefully run the new S&S® studs (31-2325) into the cases to confirm there are no burrs in the case.
- F. Remove all 8 studs and inspect the condition of the threads. Working with one stud at a time, apply red 262 Loctite® to the threads.
- G. Using the same 2-nut method as above, torque the stud to 10ft-lbs. Repeat this process for the other 7 studs.

NOTE: S&S recommends that cylinder studs not be reused. Instead new cylinder studs should be installed.

Piston Oilers and Pinion Bearings

- A. Install Special S&S piston oilers and new pinion and cam bearings. – Follow Harley-Davidson® factory procedures.

NOTE: Cam bearings must be Torrington® B-148 full complement bearing (S&S Part 31-4080), or equivalent. We do not recommend using stock Harley-Davidson® cam bearings.

3. Check Frame Clearance

NOTE: This step is recommended for 107" and 116" engines, and is particularly recommended for Harley-Davidson® Softail® frames.

- A. Mock up engine with cylinders, heads, and rocker covers. Head and rocker cover gaskets must be used.
- B. Set the mocked up engine in the frame and note any areas of interference. Frame clearance is very seldom a problem with 1999-up frames.

CAUTION

Grinding and/or peening gas tank may damage the tank causing leaks.

WARNING

Unwarranted gasoline leaks from gas tanks may overflow on surrounding area where it could catch fire possibly causing personal injury to you or others near you.

- C. Install gas tank to check for clearance problems. S&S recommends at least .060" clearance for rigid mounted engines and .250" for rubber mounted engines. Softail® models with 116" engines are the most likely to have clearance problems. We have been able to shim the gas tank at rear mount to gain the necessary clearance in this situation. Do not grind, dent, or peen gas tank to achieve clearance.

- 4. **Check internal engine clearances and assemble crankcases.** These clearance checks can be made at the same time that some assembly steps are performed. This can save time for the engine builder.

A. Piston To Head Clearance

- 1. Install flywheel assembly in right crankcase only.
- 2. Assemble pistons without rings on their proper connecting rods. Installation of wristpin clips is not necessary.

NOTE: Piston direction information is included with the instruction sheet. The rear piston skirt has a clearance notch cut in it.

- 3. Install both cylinders and temporarily secure each with one nut.
- 4. Rotate flywheel to position where pistons are at TDC. Piston deck should be flush with cylinder head gasket surface.

NOTE: Hot Set Up Kits® are designed with .045" piston to head clearance, squish, which is provided by thickness of head gasket. Therefore, pistons at TDC should be flush with head gasket surface of cylinders. If pistons are higher than cylinders at TDC, then something is wrong and S&S should be notified.

CAUTION

Insufficient clearance between piston domes and cylinder heads will damage pistons, heads and/or other engine components.

B. Connecting Rod To Crankcase Clearance

1. Rotate flywheel to positions where connecting rods are closest to crankcase and cylinder spigots in front and rear. There must be a minimum of .060" clearance between connecting rods and crankcases or cylinder spigots. See **Picture 12**.



Picture 12

2. Grind or machine crankcases or cylinder spigots if needed to achieve clearance. Connecting rod to crankcase clearance is usually not a problem with S&S® Hot Set Up Kits®, but if engines are built with longer strokes or heavier connecting rods a potential for contact exists.

NOTE: If clearancing is required. Tape off the pinion and cam bearings to prevent chips from getting into bearings.

C. Piston to Piston Clearance

1. Remove nuts holding cylinders in place. Slide cylinders up on studs about ½". Place something about ½" thick under the cylinders to hold them up. Head bolts work well for this. Raising cylinders will allow a better view of piston skirts.
2. Rotate flywheel to position where pistons are closest to each other. See **Picture 13**.



Picture 13

3. Check clearance between pistons.

NOTE: A minimum of .060" clearance is required between pistons at the closest point.

4. If additional clearance is needed, disassemble cylinders and pistons and carefully file edge of piston skirts until clearance is obtained. Clean all parts.

D. Piston to Piston Oiler Clearance. This step can be done at the same time as Step C above.

1. Rotate flywheel to position where rear piston is at bottom of travel.
2. Check clearance between piston skirt and piston oiler. See **Picture 14**.



Picture 14

3. Repeat for front piston.
4. If clearance between piston skirts and piston oilers is less than .060", install S&S Piston Oilers (S&S Part 31-2026).
5. Recheck clearance before final assembly.

E. Assemble lower end – Final assembly

1. Disassemble cylinders and pistons. Remove flywheel assembly from right crankcase.
2. Clean all lower end parts for final assembly. See notes in Section 5.
3. Install flywheel assembly. Follow factory procedure.
4. Bolt crankcases together using special S&S center case bolt with special washers installed in the order shown in Picture 5. Use S&S torque specs for crankcase bolts. Torque case bolts in two stages to 10 ft-lb. and finally 15 ft-lb. in the sequence shown in Figure 1.
5. Assemble gear case components. Follow S&S instructions if installing S&S gear drive cams. Follow factory procedures for all other components.

- F. Check valve pocket fit.
1. Install pistons without piston rings on correct connecting rods. Install cylinders.
 2. Turn engine over until piston in front cylinder is at top dead center. Paint area around valve pockets on pistons with machinist's blue.
 3. Place valves in cylinder head leaving off springs and retainers. Place head on cylinder and secure with one bolt.
 4. Lower valves until they contact piston. Rotate valve, marking painted area.
 5. Remove head and check points of contact. Valve should fit in valve pocket machined in piston dome.

NOTE: S&S® recommends at least .060" clearance around periphery of valve.

6. If insufficient clearance exists, remove piston and machine or grind valve pocket until head of valve fits flush with proper clearance.
7. Repeat procedure for other cylinder head.

G. Check Valve to piston clearance at TDC.

1. Spread layer of putty into valve pockets in both pistons.
2. Assemble cylinder heads and bolt on cylinders with head gaskets in place. Install rocker covers and pushrods. Adjust pushrods so the hydraulic piston in tappet is bottomed in the tappet bore or on the HL₂T washer if used. This insures that tappets can not bleed down so valve position will be accurate for clearance check.
3. Turn engine over in normal direction of travel two complete revolutions.
4. Disassemble engine and check thickness of putty in valve pockets.

NOTES

- S&S recommends at least .060" clearance between intake valve and piston valve pocket recess, and .080" between exhaust valve and piston valve pocket recess.
- When checking valve to piston clearance pushrods must be adjusted so the hydraulic piston in tappet is bottomed in the tappet bore or on the HL₂T washer if used. This insures that tappets can not bleed down so valve position will be accurate for clearance check.
- The earlier Harley-Davidson® Twin-Cam 88® lifters, H-D® #18538-99 & 99A, require the S&S HL₂T kit PN 33-5339. Later lifters, H-D #18538-99B, require the S&S HL₂T kit PN 33-5338. Both kits are included with the Hot Set Up Kits®, and either kit is installed & adjusted the same way - remove the retaining clip from the top of the lifter, and remove the piston assembly and spring from lifter body. Place the appropriate HL₂T travel limiter into the bore of the lifter and replace removed components in the order that they were removed. See Picture 15.

All reference to Harley-Davidson® part numbers is for identification purposes only. We in no way are implying that any of S&S® Cycle's products are original equipment parts or that they are equivalent to the corresponding Harley-Davidson® part number shown.

CAUTION

Insufficient clearance between piston and valves may cause them to contact each other during operation resulting in damage to piston and valve train components.

5. If insufficient clearance exists, machine or grind piston until proper clearance is achieved.
6. Disassemble top end and clean all parts for final assembly.

5. Final Assembly

NOTE: Cleaning parts prior to and during assembly and keeping parts clean after final assembly are imperative to minimize contaminants that may circulate in oil and shorten engine life. Many parts can be cleaned with soap and water first. Then, reclean all internal parts and gasket mating surfaces using high quality solvent that does not leave any harmful residues. Be sure to read and follow manufacturer's instruction label before use. Use drills and compressed air to clean all oil passageways of dirt, filings, etc. whenever possible. All iron or steel parts should be coated with engine oil immediately after cleaning to prevent rust. During actual final assembly, recoat all internal parts with high quality engine oil.

CAUTION

Manufacturing chips, dirt and/or other contaminants circulating in engine oil may possibly damage engine components resulting in shorter engine life and possible engine failure.

WARNING

Some solvents, degreasers and other chemicals are harmful to skin, eyes and other body parts. Many items are flammable and present a fire hazard. Read manufacturer's instruction label for proper use. Use in well ventilated area and wear protective clothing when using them to avoid personal injury.

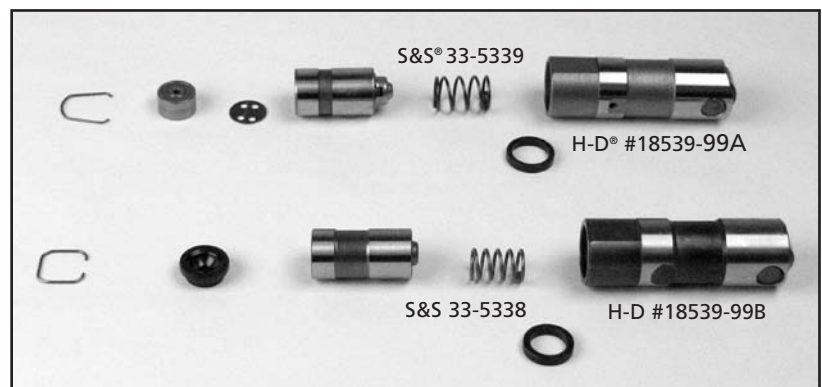

Picture 15

⚠ WARNING

Compressed air and particles dislodged by compressed air are harmful to eyes and body. Wear protective goggles when using compressed air and always direct air stream away from yourself and other people near you.

- A. Head Gasket Surface Flatness Check. Before top end is assembled, head gasket to cylinder mating surfaces should be checked.

⚠ CAUTION

Incomplete contact between gasket surfaces of cylinders and cylinder heads may cause combustion leakage possibly resulting in damage to cylinders and/or other engine components.

1. Thoroughly clean the head and cylinder gasket surfaces.
 2. Place straight edge ruler across head gasket surface at different places around diameter to determine flatness.
 3. If unevenness is revealed, machine head gasket surface just enough to make complete contact.
- B. Top End Assembly Procedure
1. Thoroughly clean all top end parts and blow dry with compressed air. Use high grade lacquer thinner on gasket surfaces.
 2. Install pistons and rings per piston instructions.
 3. Coat piston skirts with engine oil and install cylinders.
 4. Install head gaskets dry. Be sure head gaskets are properly positioned.
 5. Before installing heads spin each head bolt down on its respective stud to be sure threads are clean and free of contamination. Place a drop or two of oil on threads and under head of each head bolt just prior to final assembly.

NOTE: Light coating of oil on head bolt threads minimizes friction so torque values will not be distorted. It cannot be emphasized enough that these steps must be done carefully. Maintaining a good head gasket seal depends on it.



Top View Driveside		Stock	S&S	124
		8ft/lbs	8ft/lbs	8ft/lbs
		18ft/lbs	18ft/lbs	18ft/lbs
Camside		Turn 90° more	Turn 90° more	42ft/lbs

Figure 3

⚠ CAUTION

Improper torquing sequence and head bolt torque values may cause head gasket failure.

6. Bolt heads on cylinders. Tighten bolts in stages using crossing pattern. Follow the stock bolt tightening sequence, and use stock three stage procedure and torque values shown in Figure 3. See Figure 3.

IMPORTANT NOTE: Proper first time engine start-up and break-in is critical to achieve permanent and lasting head gasket seal. Follow engine break-in procedures at end of section.

⚠ CAUTION

Improper first time engine start-up and break-in procedure may cause head gasket failure.

7. Finish assembling top end per Harley-Davidson® specs. Install pushrods and adjust using instructions provided.

NOTE: The earlier Harley-Davidson® Twin-Cam 88® lifters, part numbers 18538-99 & 99A, require the S&S® HL₂T kit number 33-5339. Later lifters, H-D® part number 18538-99B, require the S&S HL₂T kit number 33-5338. Both kits are included with the Sidewinder® engine kits, and either kit is installed & adjusted the same way - remove the retaining clip from the top of the lifter, and remove the piston assembly and spring from lifter body. Place the appropriate HL₂T travel limiter into the bore of the lifter and replace removed components in the order that they were removed. To adjust pushrod, rotate engine until the lifter is at its lowest point, collapse the lifter with the pushrod until it bottoms against the travel limiter, and then shorten the pushrod one complete turn (6 flats of the adjuster). Tighten the locknut of the pushrod adjuster. Repeat for remaining pushrods.

NOTE: If S&S compression releases are to be installed, it is much easier to install them before rocker covers are installed and the engine is installed in the frame. S&S die-cast rocker covers for Twin Cam 88® models or similar rocker covers with a center hole must be used if S&S electric compression releases are to be installed.

8. Clean oil tank and oil cooler and flush or replace oil lines before installing engine in frame.

⚠ CAUTION

If engine is run with foreign material in the oil tank, engine damage will occur. Engine damage caused by foreign material in the oil tank is not covered under the S&S warranty.

6. Engine Break-In Procedure

NOTE: S&S engines are designed for high performance and as such are not tolerant of inadequate break-in. Correct break-in will assure longer engine life and will prevent unnecessary engine damage. Engine damage caused by improper break-in is not covered under the S&S warranty.

- A. Initial start up. Run engine approximately one minute at 1250-1750 rpm. DO NOT crack throttle or subject to any loads during this period as head gaskets are susceptible to failure at this time. During this time, check to see that oil pressure is normal, that oil is returning the oil tank, and that no leaks exist.
- B. Shut off engine and thoroughly check for any leaks or other problems. Let engine cool to the touch.
- C. After engine has cooled, start up again and allow the motor to build some heat. Engine should be run no longer than three to four minutes. When the cylinders become warm/hot to the touch (approximately 150°) shut the motor down and let it cool to room temp. Follow the same cautions as for the initial start-up, and continue to watch for problems.
- D. Repeat this procedure 3 or 4 times. Each successive time it should take slightly longer to warm up and you can increase the temp slightly each time (+10°). You can be more liberal each time with the rpm, gently vary rpm continuously from idle up to 2500 rpm in the final cycle. Don't be too concerned with final carb settings at this time because idle speed and mixture cannot be correctly set until the motor reaches full operating temperature. The motor should not reach that temperature during these cycles. Do not allow engine temperature to become excessive. After the motor has cooled to room temperature for the final time you are ready to start the 1000 mile engine break-in process.
- E. The first 50 miles are most critical for new rings and piston break-in. Engine damage is most likely to occur during this period. Keep heat down by not exceeding 2500 rpm. Avoid lugging the motor, riding in hot weather or in traffic. Vary the engine speed. Do not lug the engine. We recommend changing the oil at 50 miles.
- F. The next 500 miles should be spent running engine no faster than 3500 rpm or 60 mph. Avoid continuous steady speeds, and do not lug the engine. Vary engine rpm. We recommend changing the oil again at 500 miles.

 CAUTION

Lugging or running engine prematurely at sustained high rpm may result in damage to pistons and other engine components. S&S® voids its guarantee if engine is not broken in properly.

- G. For the balance of the first 1000 miles the motor can be run in a normal but conservative manner. You can be more liberal with the rpm range and motorcycle can be operated at normal highway speeds. Avoid overheating or putting any hard strain on the engine: no drag racing, dyno runs, excessive speed, trailer towing or sidecar operation.
- H. After 1000 miles, verify carburetor jetting and adjustment. Change the engine oil. Motorcycle can now be operated normally.

PERFORMANCE NOTES

- *Ignition system – We recommend the S&S IST (Intelligent Spark Technology) ignition. All aspects of ignition timing, advance, retard, and curves are handled automatically by the S&S IST ignition. Once the IST ignition has been installed, no other adjustments are necessary.*
- *If the S&S IST ignition is not used, S&S recommends using an electronic ignition with an adjustable advance curve.*
- *Engines built with S&S kits have higher than stock compression ratios, performance cams, and in some cases cylinder heads with combustion characteristics that are different from stock. These and other factors effect the ignition requirements of the engine. Programmable ignition systems allow ignition maps to be optimized for a specific application, but should be programmed by a qualified technician. Consult the ignition manufacturer for recommendations regarding use of a specific ignition system with large displacement high compression engines.*
- *Spark plugs - Use spark plugs and wires that are compatible with the ignition system. Dual plug installations in S&S Super Stock® heads are not generally necessary.*
- *All S&S test engines are run using S&S carburetors. S&S Super E and G carburetors are recommended for most applications with the Super G being used more often on larger displacement, freer breathing engines with higher compression ratios. Typically, engines equipped with S&S heads require the same or slightly leaner jetting than those engines fitted with stock heads. Consult the carburetor jetting instructions for specific jetting recommendations.*
- *If another type carburetor is used, it must be made to run rich enough to operate properly and to prevent engine damage. If you have a problem with another carburetor, S&S cannot help you and recommends you call the carb manufacturer with any questions you may have.*
- *If the motorcycle is used exclusively on a drag strip where engine temperatures vary, slightly richer jets may be necessary for best performance. Larger jets/richer mixtures will enable one to run a colder engine which is sometimes desirable. This is best determined by experimentation.*
- *Carburetor jetting and spark plug color - While spark plug color may be used to help determine carburetor jetting, S&S recommends that our instructions be used as primary jetting guide and that plug color indications be used only as secondary aid. We have found that different brands of gasoline, gasoline additives, engine heat (due to ignition timing), and brands of plugs and heat range used distort plug color drastically making plug reading difficult for the average tuner. Also, new plugs usually require a road test of 10 miles or more to properly develop the color which means that quarter mile tests may not be long enough and hence, not always a good indication of carb jetting. It is best to use recommended spark plug type and to consult the spark plug manufacturer if you have questions.*

Exhaust Systems

- **Muffled exhaust systems**

If you have an existing 2-into-2 system that uses slip-on style mufflers, whether it is an OEM or an aftermarket system, we recommend the new S&S® slip-on mufflers. S&S dyno tests achieve almost 8 more horsepower and 5 ft.-lbs. of torque on a stock Harley-Davidson® Twin Cam 88° engine using stock header pipes and S&S slip-on mufflers, and S&S Super Sidewinder® engines have produced 1-1.1 horsepower per cubic inch using stock headers and S&S slip-on mufflers. These mufflers will allow your engine produce more horsepower and torque than straight-through drag pipes in street and highway riding, and work equally well on both stock and large displacement engines.

- **Drag pipes**

While drag pipes can be used with good results to achieve top end horsepower, they are generally not recommended for street applications. Carburetor adjustment and jetting is generally easier for engines with muffled exhaust systems.

Gearing

- Gearing depends on the total weight of the machine and rider, the size of the engine, cam, exhaust system and type of riding to be done. Most high performance engines, and particularly those with larger displacements, are capable of pulling more gear. We suggest you break the engine in with stock gearing to minimize the load on the engine. After the engine is broken in, you will have a better feel of its potential and can change gearing accordingly.

- For those who wish to determine their final drive gear ratio the formula is as follows:

$$\text{Engine Revolutions Per One Revolution of Rear Wheel} = \frac{(\text{Clutch Sprocket}^*) \times (\text{Rear Wheel Sprocket}^*)}{(\text{Motor Sprocket}^*) \times (\text{Transmission Sprocket}^*)}$$

*Number of teeth on each sprocket

Compression

- Generally speaking, while engines with higher compression ratios make more horsepower and perform better, they also tend to lose that performance edge faster, require more maintenance, are harder to start, and require better gasoline. As a rule, we recommend a compression ratio of no greater than 11:1 for engines used in normal street operation. A word of caution is in order. Before building an engine that may be unsuitable for your application, carefully consider your riding needs, riding style and overall performance objectives.

