

## USE AND WARRANTY DISCLAIMER

SuperTrapp Industries, Inc. of 4540 W. 160th Street, Cleveland, Ohio 44135 (SuperTrapp), warrants its SuperTrapp products against defects in factory materials and workmanship for one year from the date of purchase or until ownership in the product is transferred, whichever occurs first, subject to limitations below.

Under this warranty, SuperTrapp will repair or replace defective, covered parts, at option, or provide a replacement unit. SuperTrapp makes no warranty with respect to components of the SuperTrapp product not manufactured by SuperTrapp, including, but not limited to the following: clamps, nuts, bolts, packing, boots and hoses. Repair by SuperTrapp or replacement are the exclusive remedies under this written warranty or any implied warranty. SuperTrapp will not pay for the cost of removal or re-installation of the unit from any vehicle or for delivery and pick up of the unit. To obtain service under this warranty, the original purchaser must give specific written notice to his or her dealer within fifteen (15) days after discovery of any claimed defect in the unit, and must return such unit to the dealer within a reasonable time thereafter at the cost of the original purchaser.

This limited warranty is the only express warranty applicable to SuperTrapp product. Any implied warranty of merchantability or fitness for a particular purpose is limited in duration to the duration of this written warranty. Some states do not allow limitations on how long an implied warranty lasts, so the above limitation may not apply to you.

SuperTrapp shall not be responsible for any consequential, special or incidental damages of any nature including but not limited to the loss of use of any vehicle on which the unit may be installed and the cost of obtaining another substitute product. Some states do not allow the exclusion or limitation of incidental or consequential damages so this limitation or exclusion may not apply to you.

This warranty is valid only if proper size of the unit is installed, operated and maintained in accordance with factory instructions. This warranty does not cover any damage caused by (i) modification or alteration of the unit; (ii) improper installation, maintenance, operation or use; (iii) accident; (iv) servicing or repair by anyone other than SuperTrapp or its authorized agents.

**CAUTION!** Warranty does not cover chrome discoloration. You can minimize this problem by thoroughly cleaning and polishing the system before initial start-up, being sure the fuel mixture is not too rich or too lean, and preventing long periods of engine idle.

This warranty gives you specific legal rights and you may also have other rights which vary from state to state. Outside the United States, a different warranty may apply. For details, please contact your authorized SuperTrapp distributor.

*Since 1975, SuperTrapp has built a reputation on innovation and technical superiority. SuperTrapp® R&D is constantly designing, testing and improving; providing you with the latest in state of the art performance engineering. SuperTrapp® products are absolutely the best performance items available. They will provide years of trouble-free service.*

SuperTrapp® Industries, Inc.

4540 W. 160th St. Cleveland, OH 44135

Phone: (216) 265-8400 fax: (216)265-0130

E-mail: sales@SuperTrapp.com www.SuperTrapp.com



003-7670 02.12.18



## Installation Instructions



### IMPORTANT!!

This KERKER exhaust system was developed to fit both wide and narrow tire platforms using the same mounting bracket. There are two sets of spacers supplied in the hardware kit, along with mounting bolts for the narrow tire platform. The wide tire platform will use the stock mounting bolts.

## **KERKER Bootlegger**

**135-71670:** Stainless Steel, Stepped, 2:1 with Turn Down/Turn Out End Cap.

For Harley-Davidson® Softail® Models, 2018-Up.

## REMOVAL OF STOCK SYSTEM:

1. Unplug the front and rear oxygen sensors from the stock wiring harness.  
**NOTE:** For Bootlegger installation, you will need to remove the front O2 sensor plug from the frame clip and direct it up along the cam cover to reach the new O2 sensor position. **(See Figure 3)**
2. Remove the right side passenger foot peg. Remove the pivot pin and carefully remove the foot peg along with the detent plate. Be careful not to lose the detent ball between the foot peg and the detent plate. Use a T45 Torx to remove the foot peg extension. Retain for new system installation.
3. Remove the stock exhaust system and mounting bracket as described in your service manual. Retain the flange nuts for the new system installation.
4. Remove the stock snap rings and flanges from the head pipes and retain for the new system installation. Inspect and replace snap rings if cupped or twisted. Use HD part# **65325-83A**.
5. Remove the oxygen sensors from the front and rear head pipes and retain for new system installation.
6. The exhaust gaskets should be replaced to achieve a proper fit and seal. Replacement gaskets are available from your Harley- Davidson dealer, part# **65324-83A**.

## SYSTEM INSTALLATION:

1. Install stock flanges on both head pipes using snap rings.
2. **This pipe was designed to accommodate both 12mm and 18mm oxygen sensors. When using 12mm sensors, install the 18mm-12mm adaptor supplied in the hardware kit. Apply a small amount of anti seize to the threads of the adaptor before installation. (See Figure 1)** Apply a *very light coating* of anti-seize to the threads of the oxygen sensors and install the sensors in new head pipes. **(VERY IMPORTANT: Apply anti-seize to the threads of the oxygen sensor ONLY. Contamination of the sensor probe can adversely affect engine performance.)**
3. Install the supplied exhaust mount bracket in the stock location using the hardware supplied as follows: On narrow tire models, use the 1.125" spacers and two 3/8"-16 X 2.00" socket head bolts with flat washers and lock washers. On wide tire models, use the stock mounting bolts with the .25" spacers, flat washers and lock washers. Tighten to manufacturers specifications, see service manual. **(See Figure 2)**
4. Install the (2) supplied T-bolts in the slide bracket on the head pipe collector.
5. Mount the head pipe using the stock flange nuts. Align the T-bolts with the holes in the mount bracket as you seat the head pipe in the exhaust ports. Align the flanges at the port and install the flange nuts. **DO NOT TIGHTEN.**
6. Install the supplied flat washers and lock nuts on the T-bolts. **DO NOT TIGHTEN.**
7. Tighten the head pipe starting at the ports. Tighten ports evenly, alternating from front to rear. Finish by tightening the T-bolts at the collector.
8. Reconnect the oxygen sensors to the wiring harness.
9. Re-install the passenger foot peg on the new exhaust mount bracket. Align the flat on the peg extension with the tab on the bracket. Apply Loctite to the screw and tighten to manufacturers specifications, see service manual.
10. Clean the pipe thoroughly to remove oil and finger prints before starting.

**IMPORTANT: CHECK AND RETIGHTEN ALL FASTENERS AFTER THE FIRST RIDE. RECHECK AT EACH SCHEDULED MAINTENANCE.**

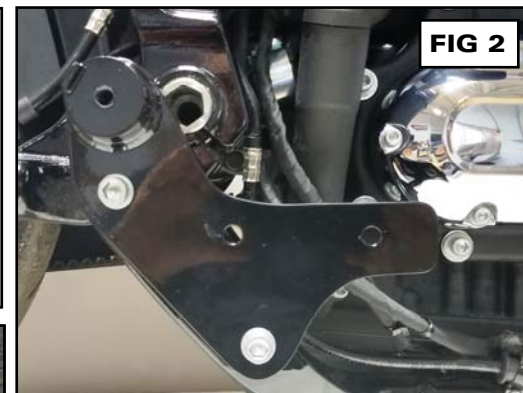
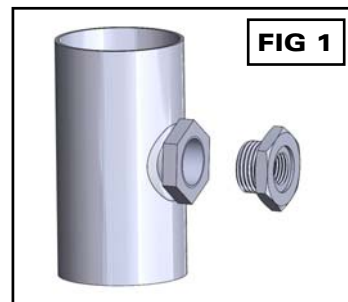

## END CAP ADJUSTMENT:

The Bootlegger head pipe is supplied with a Turn Down/Out end cap. The cap is installed as a Turn Out at the factory. To change position to a Turn Down, remove the (3) button head screws on the collector and rotate the cap downward until the cap holes line up with the collector holes. Re-install the (3) button head screws to finish the change.

## TUNING TIPS:

This system was designed to perform using a free-flowing air filter kit with a stock tune. Additional performance gains could be achieved with additional tuning. This work should always be performed by a qualified technician.

We DO NOT suggest removing the muffler packing material to "get more noise". Removing the packing will result in a loss of power, discoloration of the muffler finish, and potential failure of the mechanical core components.

## CARE AND MAINTENANCE:

Your new Bootlegger pipe must be cleaned to remove any grease, oils and other substances from the surface prior to running for the first time. Failure to clean the surface thoroughly may result in permanent stains in the surface. A high quality glass cleaner is perfect for this task.

This pipe is supplied with cleaning pads that can be used to remove burned-on substances and return your pipe to the original finish. Rub these pads radially, around the pipe, to achieve the original factory finish.

## OPTIONAL END CAPS:

108-8035	Afterburner	108-8050	Tapered
108-8048	Rolled Edge	108-8052	Slash Cut

(visit [supertrapp.com](http://supertrapp.com) for photos and product information)