

Congratulations, you have purchased the finest exhaust system available for your motorcycle. Your Vance & Hines exhaust is designed and crafted for performance, quality, and style. Please follow the instructions below, check exhaust system for missing or damaged parts and if you need any assistance please contact our technical support line (562) 921-7461.

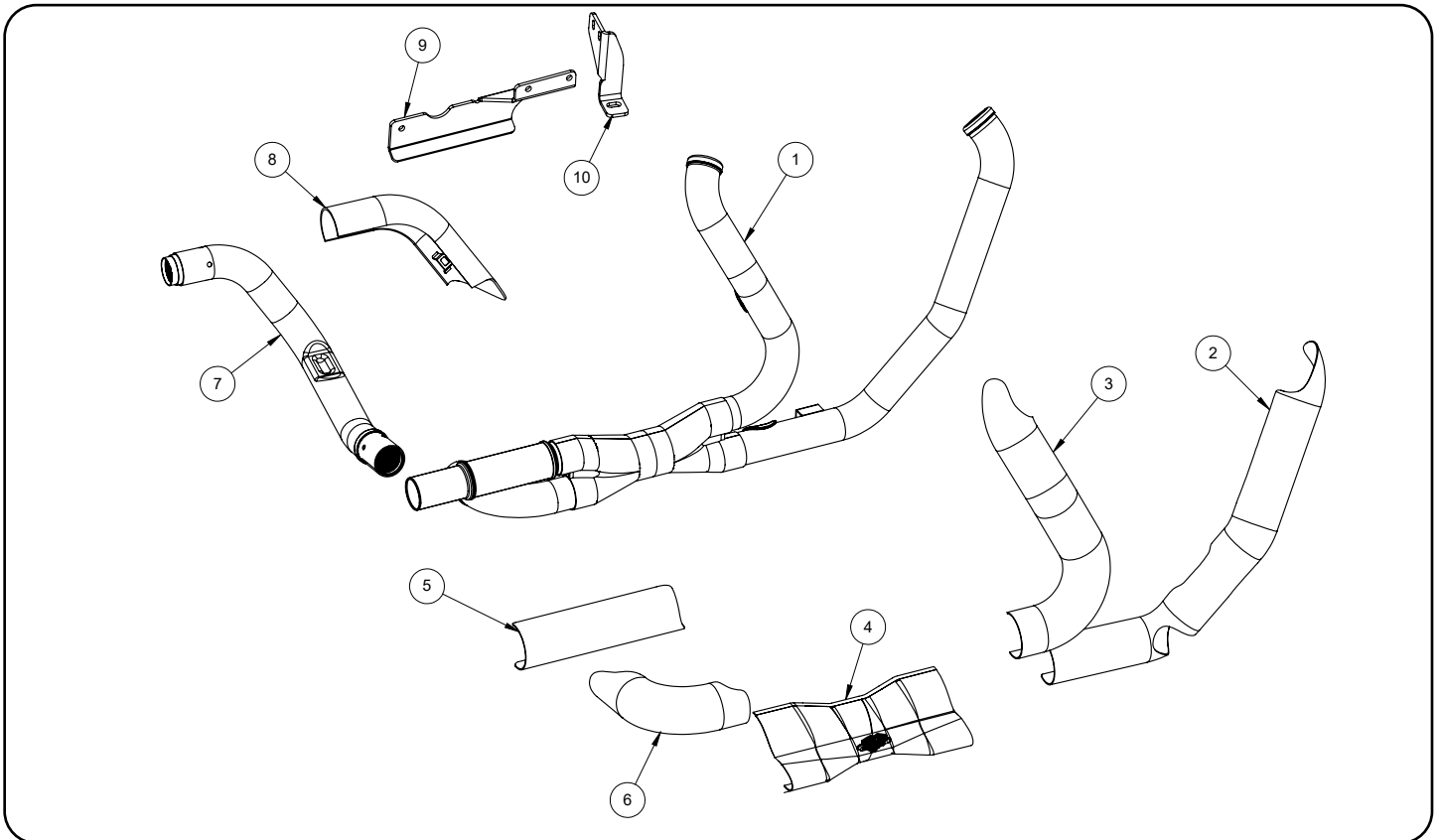

PARTS LIST

NO.	PART NO.	Description	Qty.
1	D1377FP	Front Header Section	1
2	D592HC	Front Heat Shield	1
3	D593HC	Rear Heat Shield	1
4	D1152HC-S	Collector Heat Shield	1
5	D1154HC	Straight Pipe Heat Shield	1
6	D572HC	Heat Shield Weldment	1
7	D1378FP	Rear Crossover Header	1
8	D557HC	Rear Crossover Heat Shield	1
9	760-P	Mount Bracket	1
10	564-P	Crossover Bracket	1
11	593-P	Floor Board Spacer	1
12	A335HW	Torca Band Clamp	1
13	A223CC	Header Tube Clamp	1
14	A393HW	Clamp Loop	1
15	A272HW	1.31-2.25" Hose Clamp	4
16	A270HW	.81-1.75" Hose Clamp	10
17	A102HW	3/8-16 x 3" SHCS	1
18	A312HW	1/2 x 1 x 3/16" Washer	1
19	A311HW	3/8 x 1 x 3/16" Washer	1
20	A106HW	3/8" SAE Flat Washer	1
21	A286HW	3/8" Split Lock Washer	1
22	A644ST	18-12mm O2 Adaptor	2
23	A302HW	3/8-16 x 1.25" Flange Bolt	1
24	A197HW	Dog Bone Nut Plate	1
25	A240HW	5/16-18 x 5/8" FHS	1
26	A265HW	3/8-16" Locknut	1
27	A288HW	Nylon Cable Tie	1

HARDWARE

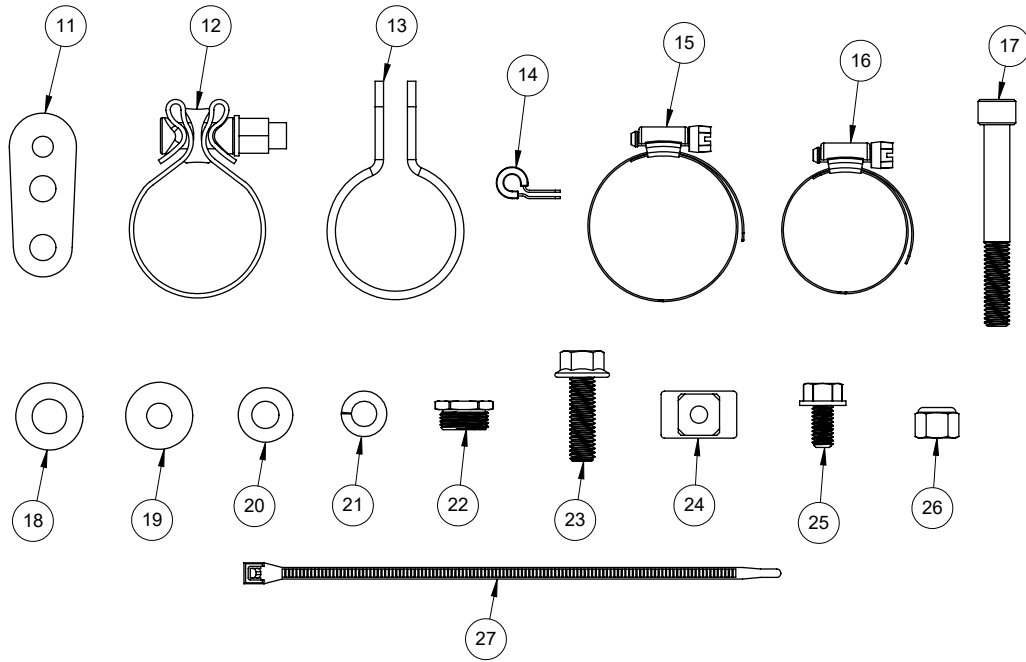

TOOLS REQUIRED

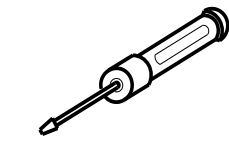

Flat blade screwdriver

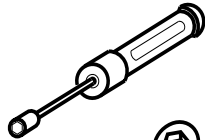

1/4" & 5/16" Nutdriver

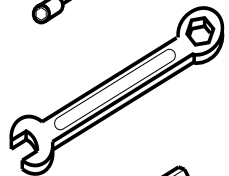

1/2", 9/16" & 14mm
Combination Wrenches

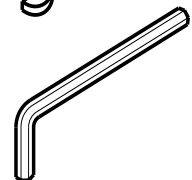

1/4", 3/16"
& 5/16" Allen wrench

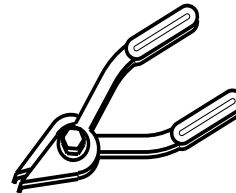

Snapping Pliers

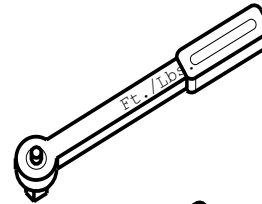

Ft./Lb. Torque Wrench

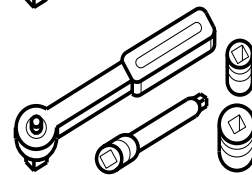

3/8" Ratchet
Extensions, 1/2", 3/4"
Socket, 1/2", 9/16" &
5/8" deep sockets

STOCK EXHAUST SYSTEM REMOVAL

1. Remove both left and right saddlebags and set them aside. Remove the right side panel.
2. Loosen the pinch clamp bolt on the front end of muffler(s). **NOTE:** On OE two into one right side only exhaust systems, there is no left side removal of mufflers required.
3. Remove the two 5/16" bolts and washers that mount the muffler(s) to the saddlebag supports. Save these for re-use.
4. Remove the stock muffler(s) and set aside. **NOTE:** It may be necessary to use a penetrating lubricant to loosen muffler(s) from the head pipe.
5. Locate and unplug the O2 sensor wires from the wiring harness (Grey and Black connectors located behind right side panel) and remove cable ties holding wires to frame. Feed the end of the wires through the frame so they are free from the motorcycle. **NOTE:** Pay attention to wire routing for re-installation.
6. Remove the right hand floor board.
7. Remove the right hand passenger floor board.
8. Loosen head pipe clamp connecting the left side muffler to the header and the mount bracket on the backside of the oil pan. Remove the crossover section of the head pipe and the head pipe clamp(OE dual muffler systems only).
9. Remove the mount clamp located behind the oil pan, set the 1/4"-20 x 3/4" screws aside for reuse.
10. Loosen the nut and carriage bolt holding the front head pipe assembly to the bracket on the transmission housing.
11. Loosen the heat shield clamps on both front and rear exhaust pipes.
12. Remove the two flange mounting nuts from each head pipe, located at the cylinder head. Carefully remove the head pipes and set aside.
13. Using a 14mm wrench, carefully remove the O2 sensors from the stock head pipes and save for re-use with the new system.
14. Carefully remove the exhaust port flanges and circlips from the stock exhaust system using snapping pliers. **NOTE:** If circlips look bent or twisted, replace them.

VANCE & HINES EXHAUST INSTALLATION

1. Check exhaust gaskets for damage, and replace if necessary.
(Part# 65324-83B or V&H Part# 22899)
2. Install the crosspipe support bracket (stamped 564-P) at the stock mount clamp location behind the oil pan with the stock 1/4"-20 x 3/4" screws. **NOTE:** Do not fully tighten at this time.
3. Replace the bracket on the transmission housing with new bracket (stamped 760-P) (supplied) tighten enough to hold bracket in place but allow for adjustment later (Figure 1).
4. Remove header assembly and heat shields from protective packaging. Place each heat shield on a non-abrasive surface such as blanket or carpet. Using a felt tip pen, mark outside edge of each heat shield to show location of mounting clips that hose clamps will loop through (Figure 5).
5. The header assembly (D1377FP) will require heat shields stamped D592HC, D593HC, D572HC, D1154HC, D1152HC-S. The remaining heat shield D557HC will be used on the crosspipe header (D1378FP).

VANCE & HINES EXHAUST INSTALLATION CONTINUED

6. Lay header assembly into heat shields and loosely install the #20 hose clamps (supplied) into mounting clips. Screw heads should be accessible when the system is installed on motorcycle for adjustment purposes (Figure 5). Do not tighten at this time.
NOTE: The D1154HC heat shield should be installed with #28 hose clamps and with the scalloped end towards the collector.
7. Use the #28 hose clamps and install the collector heat shield (D1152HC-S) over the other heat shields, it can be installed after header is installed if desired.
8. Apply a small amount of anti-sieze compound to the threads of the oxygen sensors and install them into the new head pipe. **NOTE:** 2009 models or models using 18mm wideband oxygen sensors install the sensor directly into the head pipe. 2010 and later models install supplied 18mm to 12mm oxygen sensor adapter then install the 12mm oxygen sensors (Grey connector into the front head pipe, Black connector into the rear head pipe.)
9. Install circlips and flanges from stock system onto the new header pipes.
10. Using stock flange nuts, carefully install the header assembly onto the motorcycle. Finger tight only at this time.
11. Use the nut plate and 5/16" x 5/8" flange bolt (supplied) to attach the header to the bracket. Make adjustments to the bracket as necessary to ensure proper alignment.
12. Use 1/4" Allen wrench to tighten one or both transmission bolts to hold bracket alignment. Remove header and fully tighten transmission bolts to 13 - 16 ft/lb.
13. Again, using stock flange nuts, carefully re-install the header assembly onto motorcycle. Do not tighten at this time.
14. Use the nut plate and 5/16" x 5/8" flange bolt (supplied) to attach the header to the bracket.
15. Tighten the exhaust port flange nuts.
16. Tighten the 5/16" x 5/8" flange bolt that attaches the header to the bracket.
17. Install the Torca Band Clamp (supplied), with nut facing down on the expanded end of the front head pipe.
18. Referring to Figure 2 - Fasten the crossover pipe to the crossover bracket using supplied hardware. First place the crossover bracket between the arms of the header clamp. Next insert the 3/8"-16 x 1.25 flange head bolt through the header clamp, crossover bracket, heavy 3/8" washer and once again the arm of the header clamp. Lastly install a 3/8" thin flat washer and 3/8"-16 lock nut. **NOTE:** Do not tighten at this time.
19. Loosely attach heat shield (D557HC to crossover header (D1378FP) and slip it into the end of the front head pipe approximately 1.75 inches deep.
20. Tighten the stock 1/4"-20 screws securing the bracket to the oil pan, rotate crossover head pipe (D1378FP) to proper position for muffler being used and tighten flange head bolt and locknut securing the crosspipe clamp (A223CC) to the rear transmission bracket.
21. Install the mufflers of your choice onto both head pipes and secure to saddlebag supports with the stock 5/16" bolts and lock washers. On bike equipped with OE 2 into 1 systems, Vance and Hines Left Side Mount kit #16933 may be required to complete installation.
22. Check alignment of mufflers and make corrections as required.
23. Tighten the band clamps securing the crosspipe and the mufflers to the head pipes.
24. Be sure to check that all fasteners including the hose clamps on the heat shields are tight.

VANCE & HINES EXHAUST INSTALLATION CONTINUED

25. Route the front (Grey) O₂ sensor wire along OE path and plug into the Grey connector. Route the rear (Black) O₂ sensor along the top of the transmission along the OE path and plug into the Black connector. Secure wires to the frame using supplied nylon cable ties. Remove one right rear nut securing transmission top cover. Re-install it with the supplied wire fastener capturing the rear O₂ wire, securing the wire away from exhaust pipes (Figure 3).
26. Install Spacer (593-P), on floor board support plate (Figure 4). Remove the left 3/8" socket cap screw only and place the spacer onto floor board support plate aligning the holes in the spacer with those on the support plate. Re-install the 3/8" socket cap screw into the original hole capturing spacer. **NOTE:** You may use the 3/8" stock socket cap screw to temporarily hold spacer alignment while tightening the 3/8" socket cap screw.
27. Install a 3/8" lock washer (supplied) on the 3/8"-16 x 3" socket cap screw (supplied). Using this bolt re-install the floor board with one 1" spacing washer (supplied) on the forward (right) mount. **NOTE:** Spacing washer are located between the floor board supports and floor board mount plate. On 2010-11 CVO Models, a 3/8"-16 x 1-1/2" socket cap screw (not supplied) should be used from the inside on the right mount rather than the 3/8"-16 x 3" provided bolt.
28. Re-install the right side passenger floorboard, saddlebags and right side panel.
29. Be sure to tighten all hardware before starting your motorcycle. Periodically check that all hardware is still tight.
30. After installation and before starting the motorcycle, completely clean pipes and mufflers with cleaning solvent and a clean soft cloth that will not leave residue. **NOTE:** Any residue, oil, or fingerprints will stain the chrome when the metal heats up.

WARNING: Initial start-up/heat cycle should be conducted outside or in a well-ventilated area. Smoke and odor are normal during initial heat cycle and final curing stages of coating.

EXHAUST CARE

1. When installing a new set of chrome pipes, make sure your hands are clean and free of oil. After installation, thoroughly clean pipes with a soft cloth and cleaning solvent that will leave no residue before starting the motorcycle.
2. Avoid long periods of idling as this can cause discoloration.
3. Intake leaks can cause the engine to run lean and overheat, this could lead to discoloration.
4. Make sure there are no exhaust leaks at the junction of the exhaust pipes and cylinder head. We recommend replacing gaskets if they are worn.

FIGURE 1

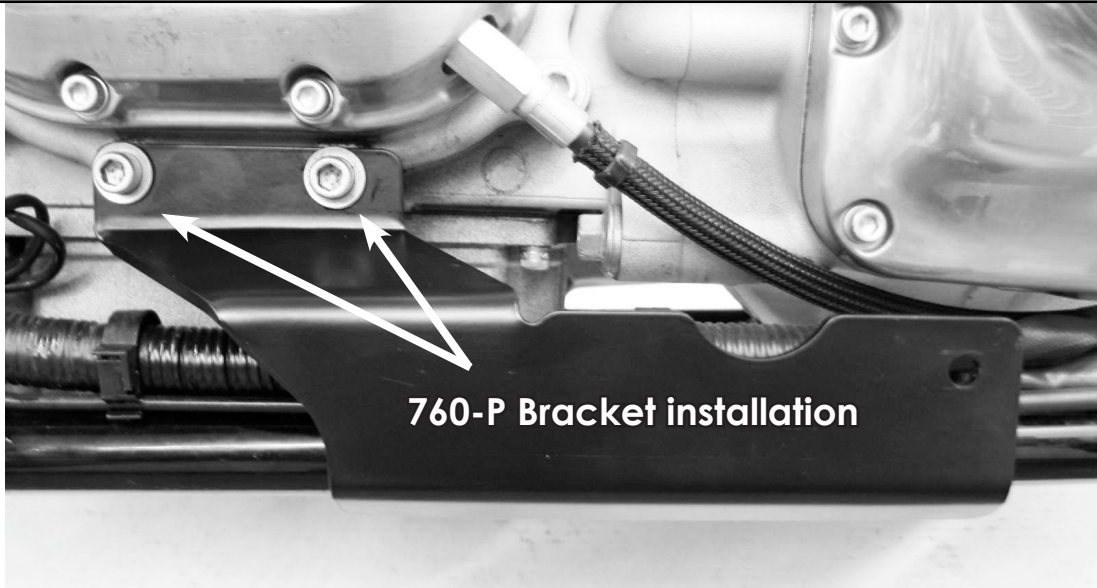

FIGURE 2

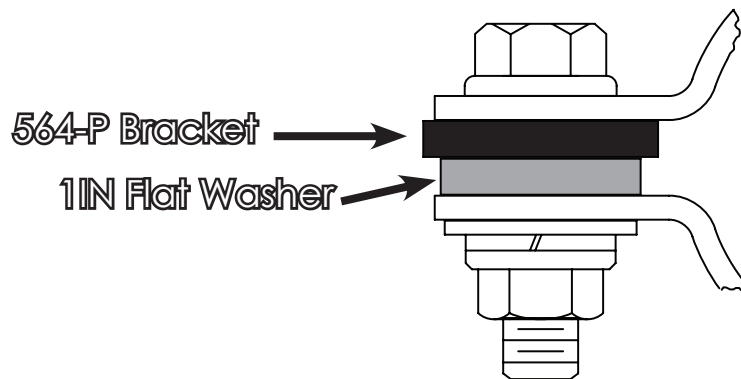

FIGURE 3



FIGURE 4

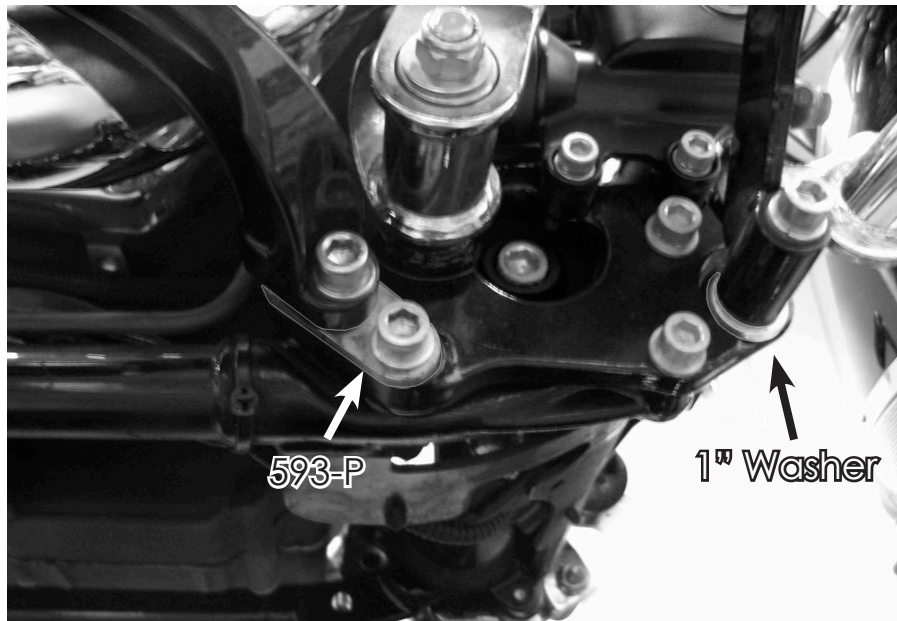
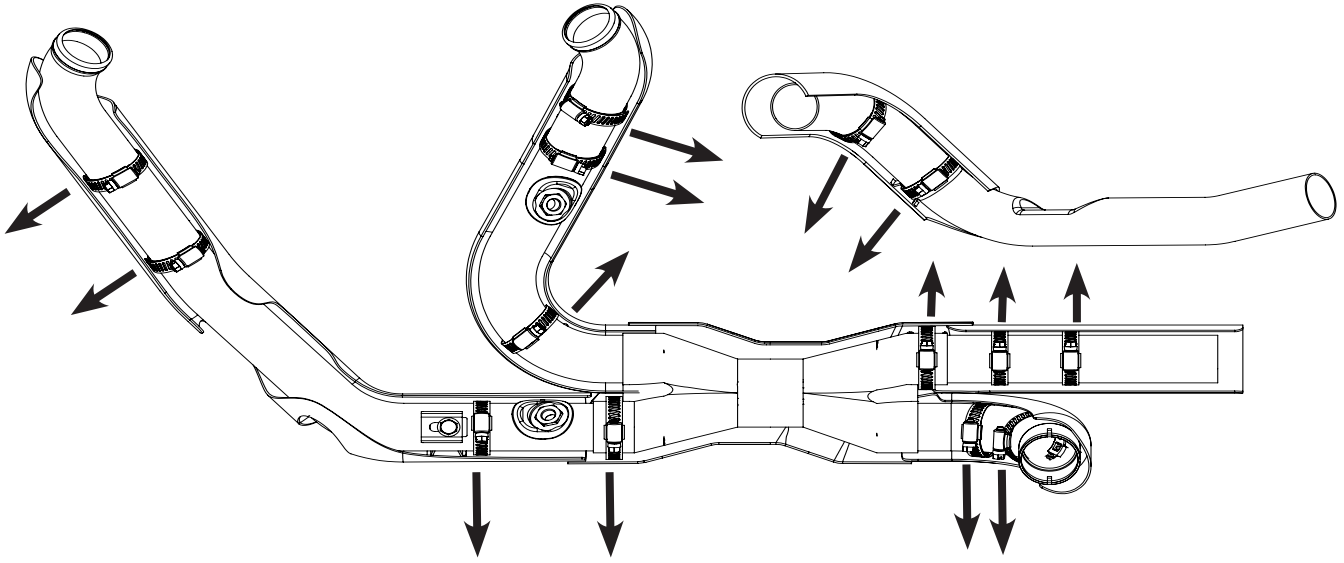

FIGURE 5



Emissions Notice:

In California, in order to meet Air Resources Board emissions requirements, certain aftermarket part applications have been identified as replacements, and others have received ARB Executive Orders. All other emissions related aftermarket parts are for competition use only. A list of replacement parts and EO parts, and corresponding fitment is provided at vanceandhines.com/california.

Warranty:

All Vance & Hines products are warranted against defects in material and workmanship for a period of 90 days. This warranty does not cover discoloration or rust. This warranty shall be limited to the repair or replacement of the product, which may be proven defective under normal use. Vance & Hines will not warranty any system that has been abused, misused, improperly installed or modified.

Dealers or distributors are not authorized to make dispositions binding upon Vance & Hines. Vance & Hines will not be responsible for any labor charges incurred in removing or replacing any system under warranty. A return authorization number and a copy of the original purchase invoice must accompany all returns. Parts returned without a return authorization may be refused

Please Note: Every effort is made for Vance & Hines Exhaust Systems to provide improved cornering clearance. However, due to design and space limitations on some motorcycle models, ground and cornering clearance may not be improved and in some cases may be reduced. Be sure to follow proper installation instructions.



Connect. Tune. Ride.

From the team that brought you The Fuelpak FP3, the best-selling ECU tuner in the world for Harley-Davidson motorcycles, the Vance & Hines FP4 is the most intuitive tuning tool on the market, giving you the power to control your motorcycle's tune and offers the best-in-industry support from our FP4 technicians, all from your smartphone.

- Download and Flash Maps
- Live Data Viewing
- Autotune Feature for Map Customization

Visit vanceandhines.com to learn more about FP4.

Qualified Manufacturer Declared 49-state Federal Emissions Compliant Part.



13861 ROSECRANS AVENUE / SANTA FE SPRINGS, CA 90670
SALES: (562) 921-5388
TECHNICAL: (562) 926-5291
FAX: (562) 802-0110

vanceandhines.com