

Please follow the instructions below, check exhaust system for missing or damaged parts and if you need any assistance please contact our technical support line (562) 921-7461.

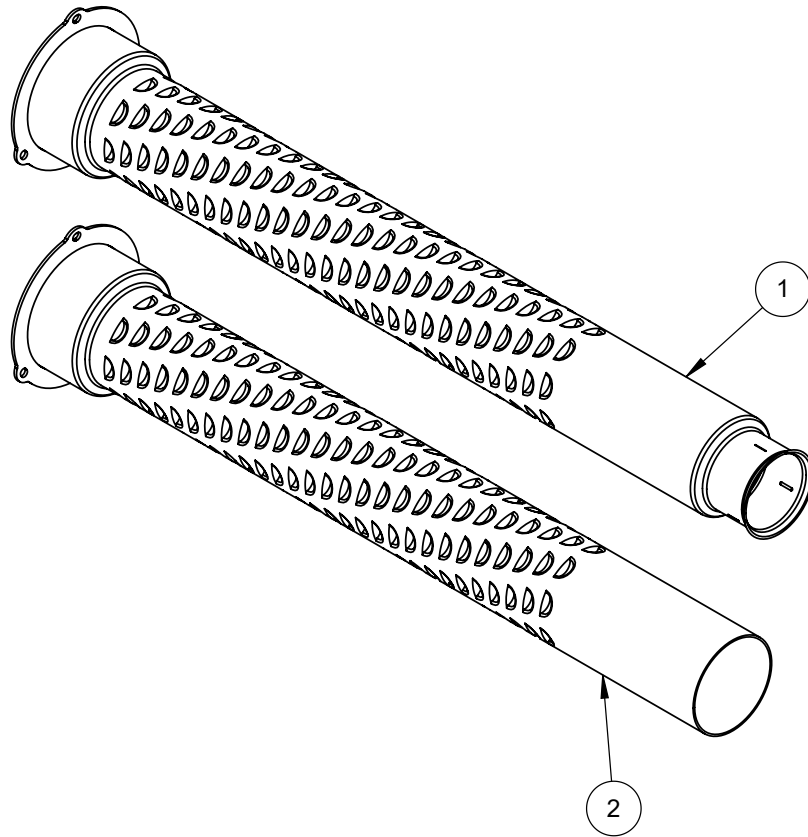

HARDWARE

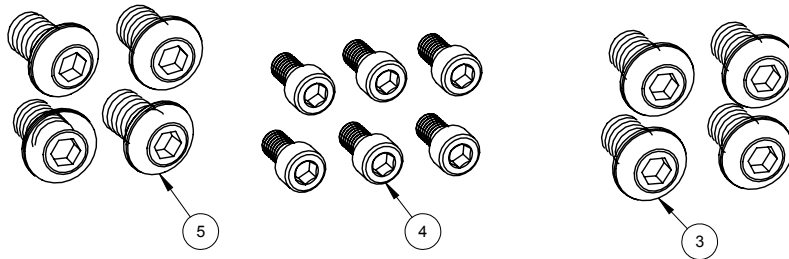

PARTS LIST

NO.	PART NO.	Description	Qty.
1	A745R	LH Quiet Baffle	1
2	A740R	RH Quiet Baffle	1
3	A157HW	5/16in-18 x 1/2in BHCS	4
4	A150HW	10-32 X 3/8" SHCS	6
5	A468HW	5/16in-18 x 1/2in BHCS, Black	4

TOOLS REQUIRED

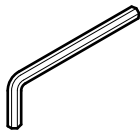

ALLEN WRENCH: 5/32

BAFFLE REMOVAL AND INSTALLATION

1. Remove the end cap. The end caps are held on by two 5/16-18 button head screws located on the bottom side of each muffler body (**Figure 1**).
2. Once the screws have been removed, remove the end cap and baffle as a unit.
3. After removal of the end cap/baffle assembly, locate the (3) 10-32 cap screws that retain the end cap to the baffle. Remove end cap screws from the baffle and discard them (**Figure 1**).
4. Install the end cap onto the new baffle using (3) 10-32 cap screws provided.
Note: Item 1 is for the left side muffler; item 2 is for the right side muffler.
5. Reinstall the end cap/baffle assembly. Carefully make sure the baffle end is properly aligned into the muffler body inlet tube.
6. Reinstall the two 5/16-18 button head bolts, use blue loctite #243 on all bolts.
7. Repeat all steps for other muffler.
8. After installation and before starting motorcycle, completely clean pipes and mufflers with warm, soapy water and a clean, soft cloth that will not leave a residue.
Note: Any residue, oil, or fingerprints will stain the finish when the metal heats up.
9. Be sure to tighten all hardware before starting your motorcycle.

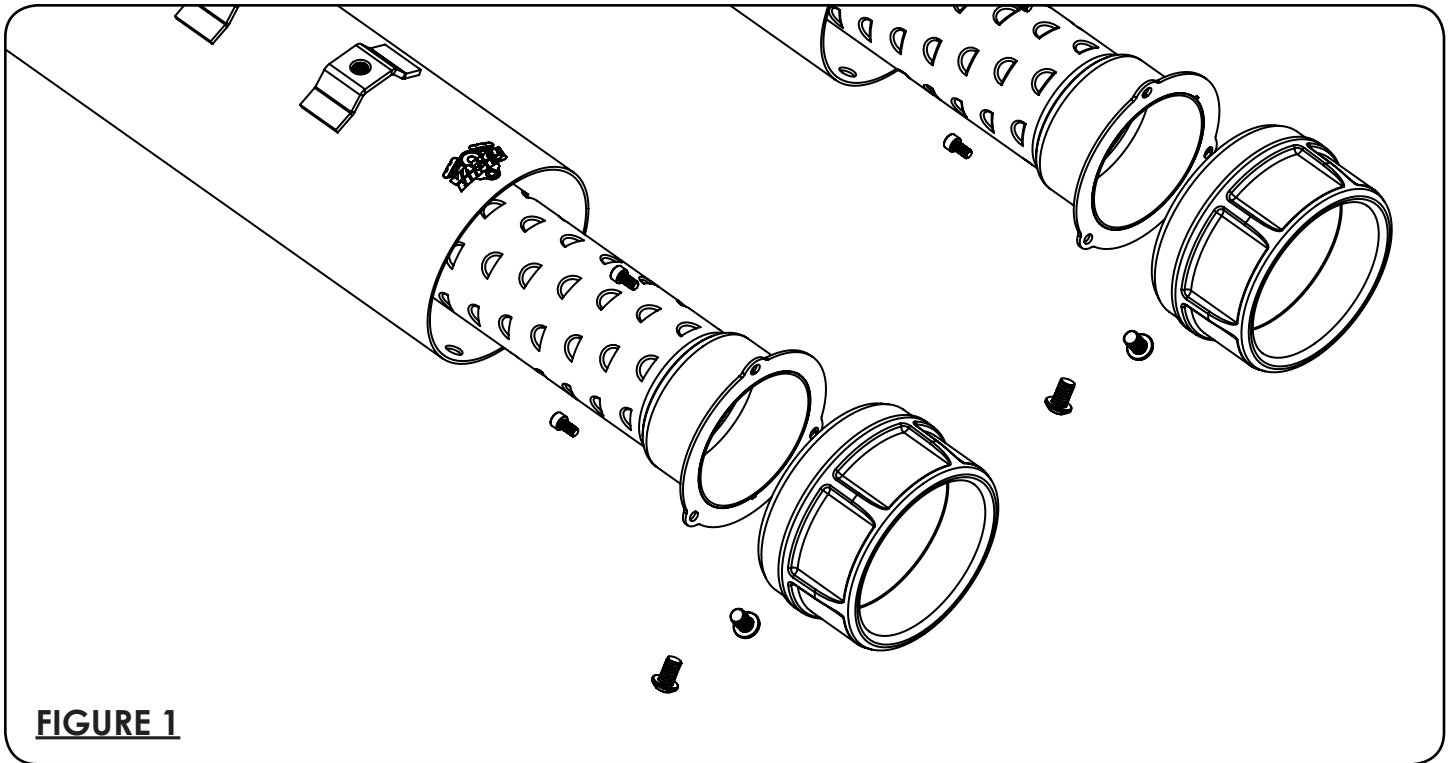

FIGURE 1

Emissions Notice:

In California, in order to meet Air Resources Board emissions requirements, certain aftermarket part applications have been identified as replacements, and others have received ARB Executive Orders. All other emissions related aftermarket parts are for competition use only. A list of replacement parts and EO parts, and corresponding fitment is provided at vanceandhines.com/california.

Warranty:

All Vance & Hines products are warranted against defects in material and workmanship for a period of 90 days. This warranty does not cover discoloration or rust. This warranty shall be limited to the repair or replacement of the product, which may be proven defective under normal use. Vance & Hines will not warranty any system that has been abused, misused, improperly installed or modified.

Dealers or distributors are not authorized to make dispositions binding upon Vance & Hines. Vance & Hines will not be responsible for any labor charges incurred in removing or replacing any system under warranty. A return authorization number and a copy of the original purchase invoice must accompany all returns. Parts returned without a return authorization may be refused.

13861 ROSECRANS AVENUE / SANTA FE SPRINGS, CA 90670
SALES: (562) 921-5388
TECHNICAL: (562) 926-5291
FAX: (562) 802-0110

vanceandhines
.com