

INSTALLATION INSTRUCTIONS: 2013-2017 HARLEY-DAVIDSON SOFTAIL BREAKOUT BIG RADIUS PART# 46365

Congratulations, you have purchased the finest exhaust system available for your motorcycle. Your Vance & Hines exhaust is designed and crafted for performance, quality, and style. Please follow the instructions below, check exhaust system for missing or damaged parts and if you need any assistance please contact our technical support line (562) 921-7461.

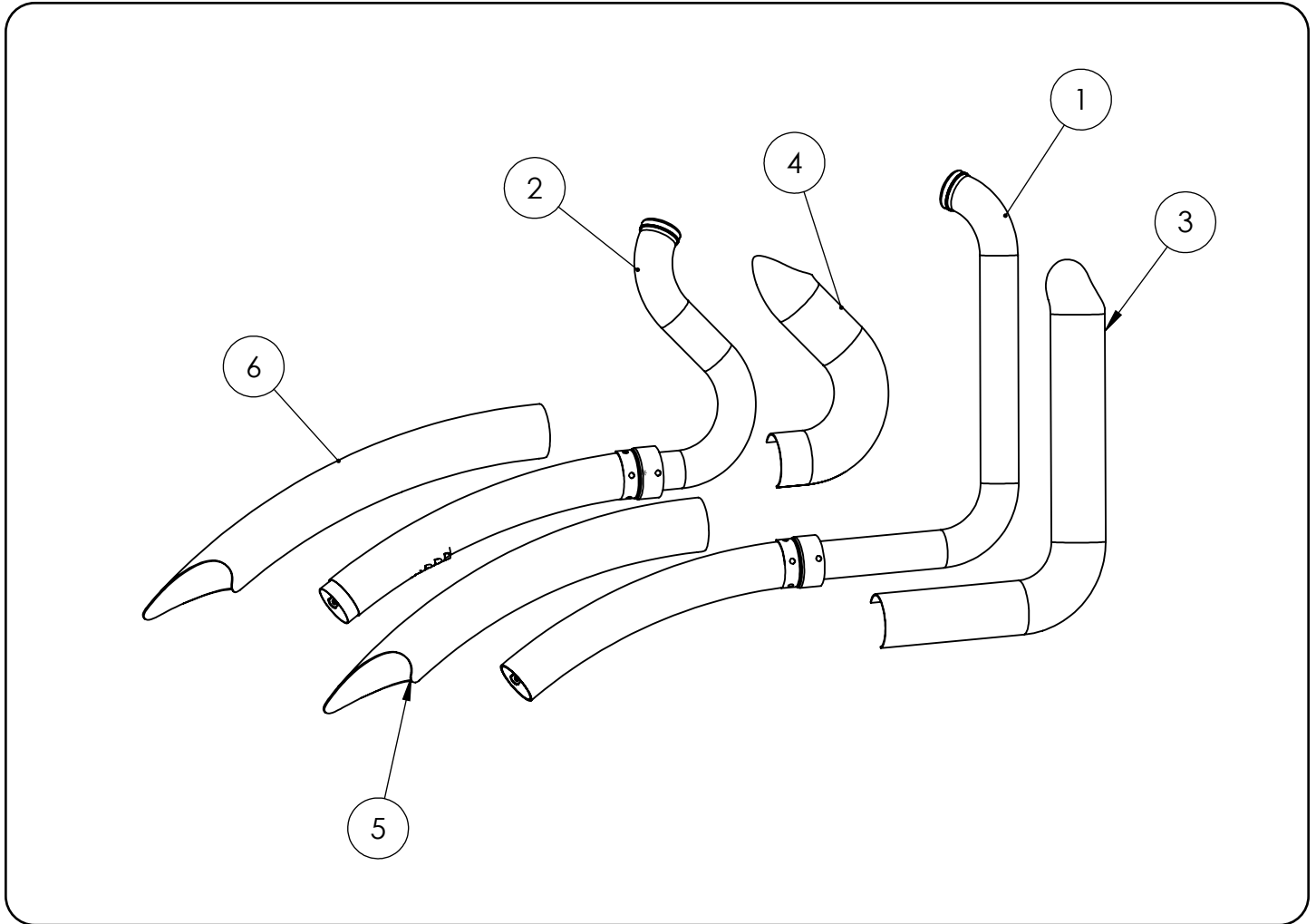

PARTS LIST

NO.	PART NO.	CH./BLK.	Description	QTY
1	D766FP		Front Head Pipe	1
2	D767FP		Rear Head Pipe	1
3	D766HP		Front Heat Shield	1
4	D787HP		Rear Heat Shield	1
5	D322HP-S		Front Muffler Heat Shield	1
6	D323HP-S		Rear Muffler Heat Shield	1
7	A288HW		Cable Tie 8inx.14in	1
8	499-P		Bracket	1
9	A195HW		Dog Bone Nut Plate	2
10	A240HW		Bolt Hex 5/16-18 X 5/8	4
11	A290HW		Bolt Hex 3/8IN-16 X 3/4 Zinc	2
12	A270HW		.81-1.75 IN Hose Clamp	5
13	A272HW		1.31-2.25IN SS Hose Clamp	4

HARDWARE

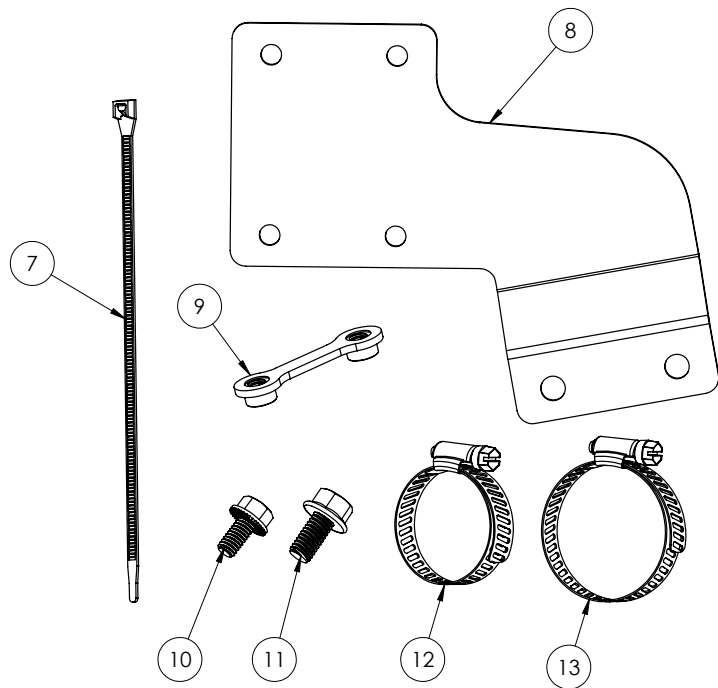

TOOLS REQUIRED

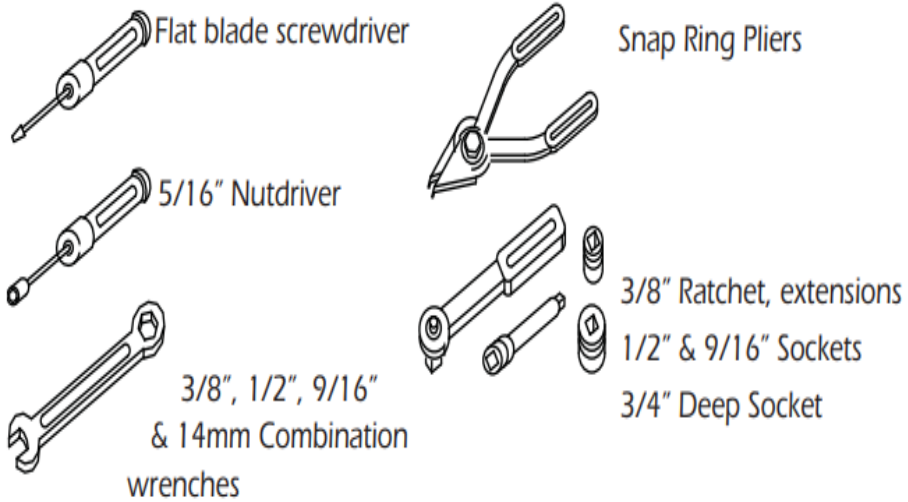

STOCK EXHAUST SYSTEM REMOVAL

NOTE: These instructions are written for late model motorcycles equipped with O₂ sensors. If you are installing these pipes on a bike which is not equipped with O₂ sensors, ignore all instructions which reference them. Additionally you will need to purchase an O₂ sensor block off kit P/N 16925.

1. Remove the seat, locate the rear O₂ sensor connector and unplug the sensor from the harness. Remove the battery and feed the sensor cable end through the frame. **NOTE:** Pay attention to wire routing for re installation. Refer to the service manual for proper battery removal.
2. Unplug the front sensor (located behind the rectifier) from harness and feed the end of the wire through the frame, freeing it from motorcycle.
3. To gain better access to the flange nuts on cylinder heads, it is recommended that you remove the front and rear heat shields from the exhaust pipes and set them aside.
4. Remove the two mounting flange nuts from each head pipe, located at cylinder head.
5. Remove the rear cylinder muffler assembly by first removing the two 1/4" flange head bolts from the underside of the rear muffler body.
6. Next, lift the muffler assembly up to release it from the crossover pipe and carefully remove the assembly from the motorcycle.
7. Remove the 9/16" nuts attaching the crossover/exhaust mount bracket to the frame.
8. Pull lightly outward to free crossover mount and carefully remove the front muffler assembly and the crossover pipe from the motorcycle.
9. Using a 14mm wrench, carefully remove the O₂ sensors from the stock head pipes and save for re-use with the new system.
10. Remove the two lower mounting studs from the frame (Figure 1).
11. Carefully remove exhaust port flanges and circlips from the stock exhaust system using snaring pliers. **NOTE:** Replace bent or damaged circlips. Check exhaust port gasket condition and replace if damaged, Recommended replacement P/N 65324-83B.

VANCE & HINES EXHAUST INSTALLATION

1. At the location where the stock mounting studs were removed (Figure1), Install bracket (stamped 499-P, supplied) using two 3/8"x3/4" flange bolts (supplied) (Figure 1).
2. Remove head pipes and heat shields from protective packaging. Place each heat shield on a non-abrasive surface such as a blanket or carpet. Using a felt tip pen, mark outside edge of each heat shield to show location of hose clamp mounting clips (Figure 3).
3. Apply a small amount of anti-seize compound to the threads of the oxygen sensors and install them into the new head pipes (Gray lead installed into the front head pipe and the black lead installed into the rear head pipe). **NOTE:** Be careful not to get anti-seize on sensor tip, it may affect sensor function.
4. Lay head pipes into head pipe heat shields (Figure 2) and loosely install the #20 hose clamps (supplied) into mounting clips (Figure 3). **NOTE:** Muffler heat shields will be installed after pipes are on the motorcycle. Screw heads should be accessible when system is installed on motorcycle for adjustment purposes (Figure 4). Do not tighten at this time.
5. Install circlips and flanges from stock system onto both new head pipes.
6. For the CVO Models so equipped, it is recommended that the swing arm bolt chrome cover (right side, with cutout) be removed (Figure 5)
7. Using stock flange nuts, carefully install head pipes onto motorcycle. Do not tighten at this time.

VANCE & HINES EXHAUST INSTALLATION CONTINUED

8. Use the nut plates and 5/16"x5/8" flange bolts (supplied) to attach the pipes to the bracket (Figure 6). Do not tighten at this time.
9. Align pipes on motorcycle so the gap between the two muffler bodies is consistent from front to rear (Figure 7).
10. Tighten the exhaust port flange nuts, the 5/16"x5/8" flange bolts (supplied) and the 3/8"x3/4" flange bolts (supplied) attaching the bracket to the frame.
11. Using the #28 hose clamps (supplied) install the muffler heat shields Beginning with the D308HC on the front head pipe followed by the D309HC on the rear head pipe. Screw heads should be accessible for adjustment purposes (Figure 4). Do not tighten at this time.
12. Adjust all heat shields for the best alignment at the seam where they meet (Figure 8) and tighten all the hose clamps. Feed connector for the front oxygen sensor (Gray) through the frame and into the holder on the frame behind rectifier. Plug the sensor into the stock wiring connector.
13. Install a new nylon cable tie (supplied) to hold the wires onto frame in the original location.
14. Feed wire for the rear O sensor through the frame and under the seat. Reinstall battery, plug the sensor into the stock wiring connector.
15. Be sure to tighten all hardware before starting motorcycle.
16. After installation and before starting the motorcycle, completely clean pipes and mufflers with cleaning solvent and a clean soft cloth that will not leave a residue. NOTE: Any residue, oil, or fingerprints will stain the chrome when the metal heats up.

EXHAUST CARE (CHROME)

1. When installing a new set of chrome pipes, make sure your hands are clean and free of oil. After installation, thoroughly clean pipes with a soft cloth and cleaning solvent that will leave no residue before starting the motorcycle.
2. Avoid long periods of idling as this can cause discoloration.
3. Intake leaks can cause the engine to run lean and overheat, this could lead to discoloration.
4. Make sure there are no exhaust leaks at the junction of the exhaust pipes and cylinder head. We recommend replacing gaskets if they are worn.

EXHAUST CARE (BLACK)

1. When installing a new set of black pipes, make sure your hands are clean and free of oil. After installation, thoroughly clean pipes with warm soapy water and a soft cloth. Dry with a clean towel to remove any residue before starting the motorcycle. Do NOT use anything abrasive to clean the pipes.
2. Avoid long periods of idling as this can cause discoloration.
3. Intake leaks can cause the engine to run lean and overheat, this could lead to discoloration.
4. Make sure there are no exhaust leaks at the junction of the exhaust pipes and cylinder head. We recommend replacing gaskets if they are worn.

FIGURE 1
Install Bracket

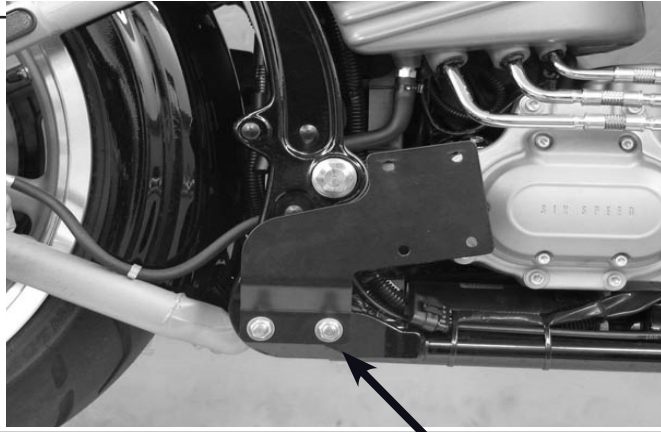

Remove Stock Studs

FIGURE 2

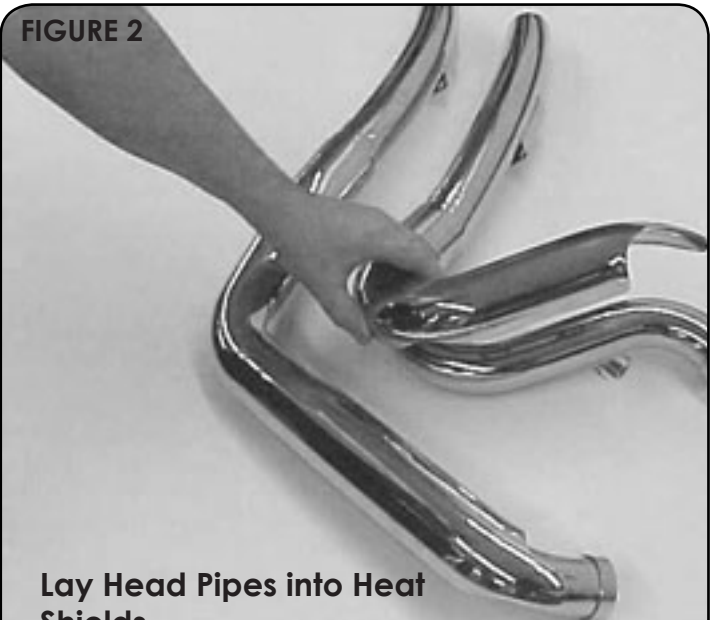

Lay Head Pipes into Heat Shields

FIGURE 3



Install hose clamps

Mark Mounting Clip Locations

FIGURE 4

Arrows indicate screw head direction

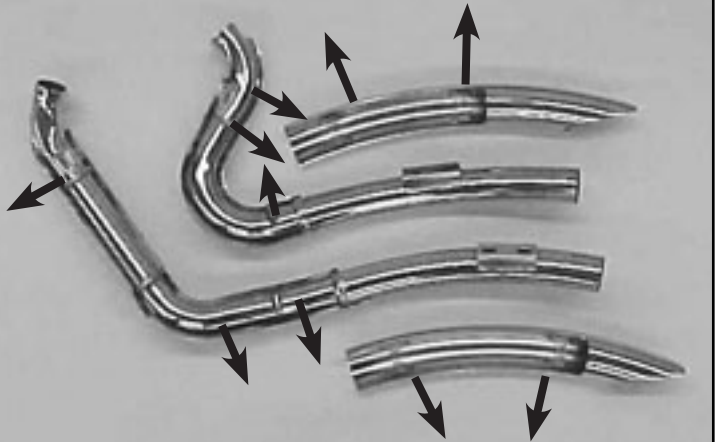

FIGURE 5



FIGURE 6

Install dog bone nut plate



FIGURE 7



FIGURE 8



Emissions Notice:

In California, in order to meet Air Resources Board emissions requirements, certain aftermarket part applications have been identified as replacements, and others have received ARB Executive Orders. All other emissions related aftermarket parts are for competition use only. A list of replacement parts and EO parts, and corresponding fitment is provided at vanceandhines.com/california.

Warranty:

All Vance & Hines products are warranted against defects in material and workmanship for a period of 90 days. This warranty does not cover discoloration or rust. This warranty shall be limited to the repair or replacement of the product, which may be proven defective under normal use. Vance & Hines will not warranty any system that has been abused, misused, improperly installed or modified.

Dealers or distributors are not authorized to make dispositions binding upon Vance & Hines. Vance & Hines will not be responsible for any labor charges incurred in removing or replacing any system under warranty. A return authorization number and a copy of the original purchase invoice must accompany all returns. Parts returned without a return authorization may be refused.

13861 ROSECRANS AVENUE / SANTA FE SPRINGS, CA 90670

SALES: (562) 921-5388

TECHNICAL: (562) 926-5291

FAX: (562) 802-0110

vanceandhines
.com